Laminox Srl

Project # 23-209

Model: Phenix Air

AKA: Lydia Natural

Type: Pellet-Fired Room Heater

November 22, 2023

Revised: April 24, 2024

**ASTM E2779 Standard Test Method for
Determining Particulate Matter
Emissions from Pellet Heaters (EPA
ALT-146)**

Contact: Luigi Rafaiani
Zona Industrial Callarella 261/263
62028 Sarnano, MC
Italy
+38 335 611 3280

Prepared by: Aaron Kravitz, Testing
Supervisor



**11785 SE Highway 212 – Suite 305
Clackamas, OR 97015-9050
(503) 650-0088**

WWW.PFSTECO.COM

Revision History

11/22/2023 – Original Issue

3/13/2024 – The following changes were made per request from EPA:

- Added additional information regarding tunnel velocity measurement equipment, see page 7.

- Added updated manual to Appendix B with additional information on replacement parts.

4/24/2024 – Corrected manufacturer name on page 8.

Contents

Affidavit	4
Introduction	5
Notes	5
Pellet Heater Identification and Testing	6
Test Procedures and Equipment	7
Results	8
Summary Table	8
Test Run Narrative	8
Run 1	8
Test Conditions Summary	9
Appliance Operation and Test Settings	9
Settings & Run Notes	9
Appliance Description	10
Appliance Dimensions	10
Test Fuel Properties	13
Pellet Fuel Analysis	14
Sampling Locations and Descriptions	15
Sampling Methods	16
Analytical Methods Description	16
Calibration, Quality Control and Assurances	16
Appliance Sealing and Storage	16
Sealing Label	16
Sealed Unit	17
List of Appendices	17

Affidavit

PFS-TECO was contracted by Laminox Srl to provide testing services for the Phenix Air Pellet-Fired Room Heater per ASTM E2779, *Determining PM Emissions from Pellet Heaters*. All testing and associated procedures were conducted at PFS-TECO's Portland Laboratory on 10/16/2023. PFS-TECO's Portland Laboratory is located at 11785 SE Highway 212 – Suite 305, Clackamas, Oregon 97015. Testing procedures followed EPA ALT-146 / ASTM E2779. Particulate sampling was performed per ASTM E2515, *Standard Test Method for Determination of Particulate Matter Emissions Collected by a Dilution Tunnel*.

PFS-TECO is accredited by the U.S. Environmental Protection Agency for the certification and auditing of wood heaters pursuant to subpart AAA of 40 CFR Part 60, New Source Performance Standards for Residential Wood Heaters and subpart QQQQ of 40 CFR Part 60, Standards of Performance for New Hydronic Heaters and Forced Air Furnaces, Methods 28R, 28WHH, 28 WHH-PTS, and all methods listed in Sections 60.534 and 60.5476. PFS-TECO holds EPA Accreditation Certificate Numbers 4 and 4M (mobile). PFS-TECO is accredited by IAS to ISO 17020:2012 "Criteria for Bodies Performing Inspections", and ISO 17025:2005 "Requirements for Testing Laboratories." PFS-TECO is also accredited by Standards Council of Canada to ISO 17065:2012 "Requirements for Bodies Operating Product Certification Systems."

The following people were associated with the testing, analysis and report writing associated with this project.



Aaron Kravitz, Testing Supervisor

Introduction

Laminox Srl of Sarnano, MC, Italy contracted with PFS-TECO to perform EPA certification testing on Phenix Air Pellet-Fired Room Heater. All testing was performed at PFS-TECO's Portland Laboratory. Testing was performed by Mr. Aaron Kravitz.

Notes

- Prior to start of testing, 50 hours of conditioning was performed by the manufacturer at a medium heat setting, per ASTM E2779
- Prior to start of testing, the dilution tunnel was cleaned with a steel brush.
- A separate, independent sample train was utilized to determine 1st hour emissions.
- A single test was performed in accordance with EPA ALT-146 burn rate settings:
 - 1 Hour at Maximum Burn Setting
 - 2 Hours at Medium Burn Setting (less than the mid-point of the high and low rates)
 - 3 Hours at Minimum Burn Setting

Pellet Heater Identification and Testing

- Appliance Tested: **Phenix Air**
- Serial Number: **N/A – Prototype Unit; PFS Tracking #0163**
- Manufacturer: **Laminox Srl**
- Catalyst: **No**
- Heat exchange blower: **None**
- Type: **Pellet Stove**
- Style: **Free Standing**
- Date Received: **Monday, September 18, 2023**
- Testing Period – Start: **Monday, October 16, 2023** Finish: **Monday, October 16, 2023**
- Test Location: **PFS-TECO Portland Laboratory, 11785 SE HWY 212 - Suite 305, Clackamas, OR 97015**
- Elevation: **≈131 Feet above sea level**
- Test Technician(s): **Aaron Kravitz**
- Observers: **N/A**

Test Procedures and Equipment

All Sampling and analytical procedures were performed by Aaron Kravitz. All procedures used are directly from ASTM E2779 and ASTM E2515. See the list below for equipment used. See Appendix C submitted with this report for calibration data.

Equipment List:

Equipment ID#	Equipment Description
189	Mettler Toledo 3'x3' floor scale w/digital weight indicator
053	APEX XC-60 Digital Emissions Sampling Box A
054	APEX XC-60 Digital Emissions Sampling Box B
203	APEX XC-50-DIR Digital Emissions Sampling Box C
055	APEX Ambient sampling box
215	NI Temperature DAQ
057	California Analytical ZRE CO ₂ /CO/O ₂ IR ANALYZER
109A/B	Troemner 100mg/200mg Audit Weights
107	Sartorius Analytical Balance
097	10 lb audit weight
095	Anemometer
111	Microtector
CC121798	Gas Analyzer Calibration Span Gas
CC139173	Gas Analyzer Calibration Mid Gas

Dilution Tunnel Velocity Measurement

In accordance with test method ASTM E2515, dilution tunnel velocity was measured prior to each run by performing a velocity traverse, and monitored throughout each run by measuring pitot pressure at the tunnel centroid. Traverses were performed using a Dwyer Model 1430 Microtector in accordance with the instrument owners' manual. This includes leveling and zeroing the instrument prior to each use and performing pre- and post-test leak checks on the pitot tubing. To monitor and log centroid pitot pressure, the pressure transducer of an Apex Instruments XC-60-DIR sample box was used. This piece of equipment, #203B, is calibrated annually and its certificate may be found in Appendix C. Both pieces of equipment offer precision in excess of the +/-0.001" specified in section 6.1.5 of ASTM E2515, and are therefore suitable for use with flows under 800 ft/min. Both pieces of equipment are plumbed to the same pitot tube.

Results

The integrated test run emission rate for test Run 1 was measured to be **1.3 g/hr** with a Higher Heating Value efficiency of **79%** and a CO emission rate of **0.08 g/min**. The calculated first hour particulate emission rate was **4.9 g/hr**. The Laminox Model Phenix Air Pellet-Fired Room Heater meets the 2020 PM emission standard of ≤ 2.0 g/hr per CFR 40 part 60, §60.532 (b).

Detailed individual run data can be found in Appendix A submitted with this report.

Summary Table

EPA Application Table												
Run Number	Date	Segments		Run Time (min)	Heat Output (BTU/hr)	1st Hr Emissions (g/hr)	Integrated Total (g/hr)	CO Emissions (g/min)	Overall CO Emissions (g/min)	Heating Efficiency (%HHV)	Overall Heating Efficiency (%HHV)	
		Setting	BR									
1	10/16/2023	OA	1.28	360	19315	4.9	1.3	0.08	0.08	79%	79%	
		H	2.30	60	35281					0.13		80%
		M	1.26	120	18891					0.08		78%
		L	0.95	180	14245					0.07		78%

Test Run Narrative

Run 1

Run 1 was performed on 10/16/2023 as an attempted integrated test run per EPA ALT-146/ ASTM E2779. The overall test duration was 360 minutes. The particulate emissions rate for the integrated test run was 1.3 g/hr. The run had an overall HHV efficiency of 79%. A separate filter train C was run for the first hour of the run only. All test results were appropriate and valid and the burn rate requirement for the integrated test run were achieved. There were no anomalies and all criteria were met.

Test Conditions Summary

Testing conditions for all runs fell within allowable specifications of ASTM E2779 and ASTM E2515. A summary of facility conditions, fuel burned, and run times is listed below.

Runs	Ambient (°F)		Relative Humidity (%)		Average Barometric Pressure (In. Hg.)	Preburn Fuel Weight (lbs)	Test Fuel Weight (lbs)	Test Fuel Moisture (%DB)	Test Run Time (Min)
	Pre	Post	Pre	Post					
1	69	74	58.2	51.7	29.82	4.5	17.3	2.6%	360

Appliance Operation and Test Settings

The appliance was operated according to procedures as described in the Operations Manual, found in Appendix B submitted with this report. Detailed run information can be found in Appendix A submitted with this report.

Settings & Run Notes

	Pre-Burn	Test Run		
Run 1	Air slide - Maximum	Maximum Segment Air slide - Maximum	Medium Segment Air slide – open ½"	Minimum Segment Air Slide – Fully closed

Appliance Description

Model(s): Phenix Air

Appliance Type: Gravity Fed, Pellet-Fired Room Heater

Additional Models: One additional model, the Lydia Natural, is available. It differs only in external cladding; it is identical in all respects that may affect emissions performance to the Phenix Air.

Air Introduction System: Air is introduced through a variable-opening sliding plate located at the bottom of the firebox. This slide is actuated by a lever located at the top of the unit.

Combustion Control: The appliance features no electronic combustion control, combustion rate is adjusted entirely through manual adjustment of the air introduction system.

Fueling System: The Phenix Air utilizes a gravity-feed system with no electrical components. The hopper is located above and behind the firebox, and when the feed slide is rotated to the on position, pellets flow down into the firebox. As the pellets in the firebox combust, they are replaced by new pellets from the feed chute.

Baffles: N/A

Flue Outlet: Venting is through a 6" diameter flue collar located at the top of the unit.

Appliance Dimensions

Phenix Air Dimensions

Height	Width	Depth	Firebox Volume
55"	19"	21.5"	N/A – Pellet Stove

Appliance design drawings can be found in Appendix D submitted with the CBI copy of this report.

Appliance Front



Appliance Left



Appliance Right



Appliance Rear



Test Fuel Properties



Test fuel used was Golden Fire Wood Pellet Fuel, a PFI Certified Premium Pellet Brand. A sample of pellets was sent to Twin Ports Testing for analysis, see report below.

Pellet Fuel Analysis



Twin Ports Testing, Inc.
 1301 North 3rd Street
 Superior, WI 54880
 p: 715-392-7114
 p: 800-373-2562
 f: 715-392-7163
 www.twinportstesting.com

Report No: USR:W223-0426-01
Issue No: 2
 Revised Report. Previous report is USR:W223-0426-01 Issue number 1

Analytical Test Report

Client: PFS-TECO
 11785 SE Hwy 212 Ste 305
 Clackamas, OR 97015
Attention: Sebastian Button
PO No:

Signed: *Katy Jahr*
 Katy Jahr
 Chemistry Lab Supervisor
Date of Issue: 8/23/2023
THIS DOCUMENT SHALL NOT BE REPRODUCED EXCEPT IN FULL

Sample Details
Sample Log No: W223-0426-01 **Sample Date:**
Sample Designation: Pellets **Sample Time:**
Sample Recognized As: **Arrival Date:** 8/1/2023

	METHOD	UNITS	MOISTURE		AS
			FREE	RECEIVED	
Moisture Total	ASTM E871	wt. %		2.54	
Ash	ASTM D1102	wt. %	0.20		0.19
Volatile Matter	ASTM D3175	wt. %			
Fixed Carbon by Difference	ASTM D3172	wt. %			
Sulfur	ASTM D4239	wt. %	0.009		0.009
SO ₂	Calculated	lb/mmbtu			0.020
Net Cal. Value at Const. Pressure	ISO 1928	GJ/tonne	18.29		17.77
Gross Cal. Value at Const. Vol.	ASTM E711	Btu/lb	8702		8481
Carbon	ASTM D5373	wt. %	47.19		46.00
Hydrogen*	ASTM D5373	wt. %	9.01		8.79
Nitrogen	ASTM D5373	wt. %	< 0.20	<	0.20
Oxygen*	ASTM D3176	wt. %	> 43.39	>	42.29

*Note: As received values do not include hydrogen and oxygen in the total moisture.

Chlorine	ASTM D6721	mg/kg			
Fluorine	ASTM D3761	mg/kg			
Mercury	ASTM D6722	mg/kg			
Bulk Density	ASTM E873	lbs/ft ³			
Fines (Less than 1/8")	TPT CH-P-06	wt. %			
Durability Index	Kansas State	PDI			
Sample Above 1.50"	TPT CH-P-06	wt. %			
Maximum Length (Single Pellet)	TPT CH-P-06	inch			
Diameter, Range	TPT CH-P-05	inch			to
Diameter, Average	TPT CH-P-05	inch			
Stated Bag Weight	TPT CH-P-01	lbs			
Actual Bag Weight	TPT CH-P-01	lbs			

Comments:



Accreditation #60243

Results issued on this report only reflect the analysis of the sample submitted. Our reports and letters are for the exclusive and confidential use of our clients and may not be reproduced, except in their entirety, without the written approval of Twin Ports Testing. Twin Ports Testing Laboratory is accredited to the ISO/IEC 17025:2017 standard by PJLA.

Sampling Locations and Descriptions

Sample ports are located 16.5 feet downstream from any disturbances and 2 feet upstream from any disturbances. Flow rate traverse data was collected 8 feet downstream from any disturbances and 4 feet upstream from any disturbances. (See below).

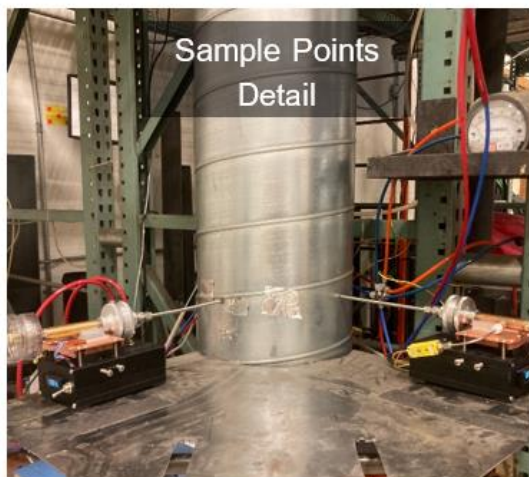

Sampling Methods

ASTM E2515 was used in collecting particulate samples. The dilution tunnel is 12 inches in diameter. All sampling conditions per ASTM E2515 were followed. No alternate procedures were used.

Analytical Methods Description

All sample recovery and analysis procedures followed ASTM E2515 procedures. At the end of each test run, filters, O-Rings and probes were removed from their housings, dessicated for a minimum of 24 hours, and then weighed at 6 hour intervals to a constant weight per ASTM E2515-11 Section 10.

Calibration, Quality Control and Assurances

Calibration procedures and results were conducted per EPA Method 28R, ASTM E2515-11 and ASTM E2780-10. Test method quality control procedures (leak checks, volume meter checks, stratification checks, proportionality results) followed the procedures outlined.

Appliance Sealing and Storage

Upon completion of testing, the appliance was secured with metal strapping and the seal below was applied, the appliance was then returned to the manufacturer’s location at: Zona Industrial Callarella 261/263, 62028 Sarnano, MC, Italy for archival.

Sealing Label

ATTENTION:

THIS SEAL IS NOT TO BE BROKEN WITHOUT PRIOR AUTHORIZATION FROM THE UNITED STATES ENVIRONMENTAL PROTECTION AGENCY.

THIS APPLIANCE HAS BEEN SEALED INACCORDANCE WITH REQUIREMNTS OF 40CFR PART 60 SUBPART AAA §60.535 (a)(2)(vii)

REPORT # _____

DATE SEALED _____

MANUFACTURER _____

MODEL # _____

Sealed Unit

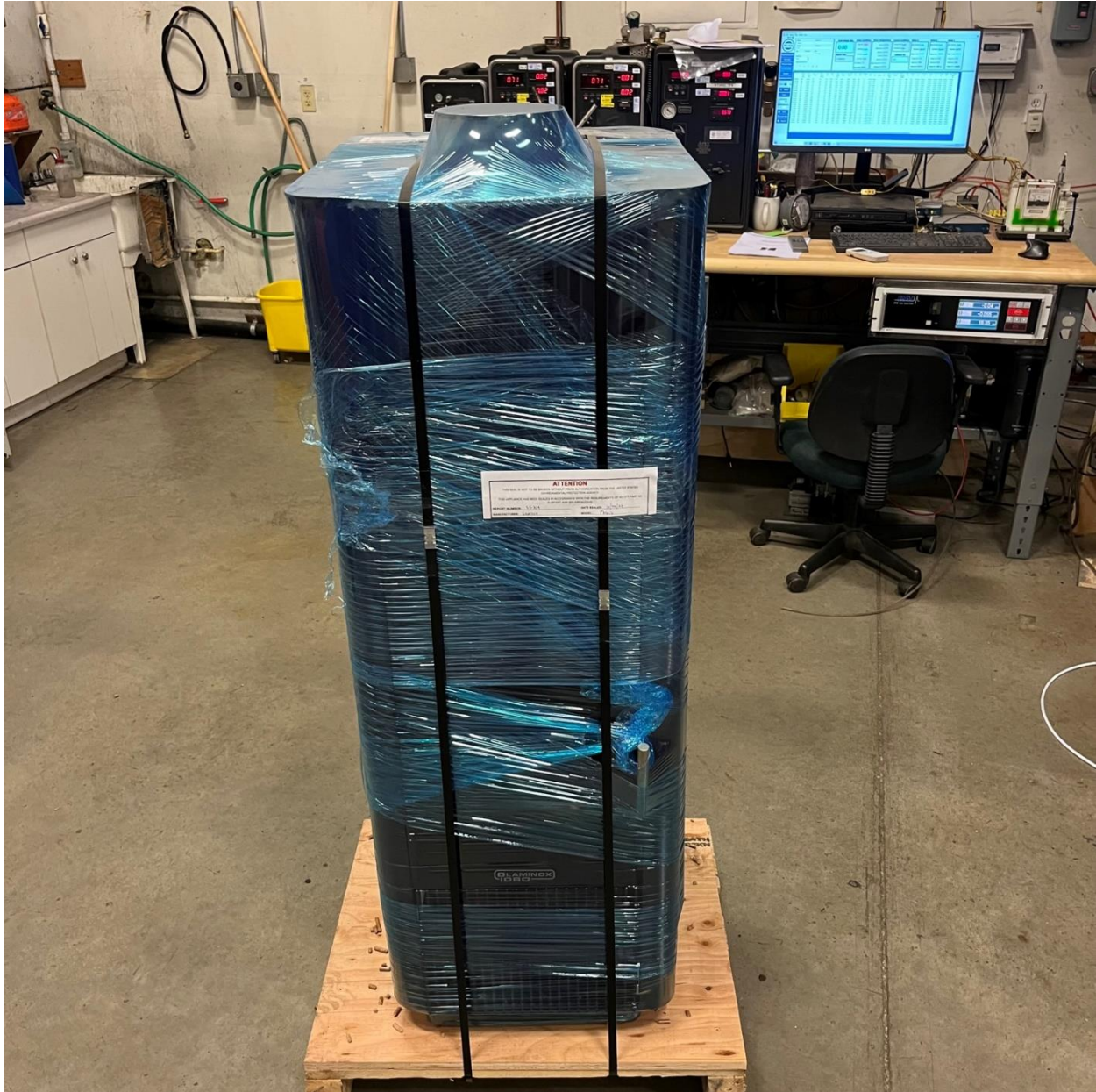

List of Appendices

The following appendices have been submitted electronically in conjunction with this report:

Appendix A – Test Run Data, Technician Notes, and Sample Analysis

Appendix B – Labels and Manuals

Appendix C – Equipment Calibration Records

Appendix D – Design Drawings (CBI Report Only)

Appendix E – Manufacturer QAP (CBI Report Only)



UNITED STATES ENVIRONMENTAL PROTECTION AGENCY
RESEARCH TRIANGLE PARK, NC 27711

OFFICE OF
AIR QUALITY PLANNING
AND STANDARDS

Mr. John Steinert
Vice President
PFS TECO
11785 SE Hwy 212
Suite 305
Clackamas, OR 97015

02/04/2022

Dear Mr. Steinert,

I am writing you in response to your correspondence dated February 3, 2022, in which you request the use of an alternative testing procedure to demonstrate compliance with 40 CFR part 60, Subpart AAA – Standards of Performance for New Residential Wood Heaters (Subpart AAA). The Office of Air Quality Planning and Standards, as the delegated authority, must make the determination on any major alternatives to test methods and procedures required under 40 CFR parts 59, 60, 61, 63, and 65. Your proposed alternative test method and our approval decisions are discussed below.

According to the information provided, you seek an alternative test method for use when conducting testing on the United States Stove Company, Model KP5517 pellet heater. Currently, as required by section 60.534(a)(1)(i) of Subpart AAA, a manufacturer has the option to test their appliance in accordance with 40 CFR part 60, Appendix B, Method 28R for a crib fuel appliance or ASTM E2779-10 “Standard Test Method for Determining Particulate Matter Emissions from Pellet Heaters” (ASTM E2779-10) for a pellet fuel appliance. This request seeks an alternative to section 9.4.1.2 of ASTM E2779-10 which specifies test conditions for pellet heaters including the determination of the Medium Burn Rate Category and states that the medium burn rate must be $\leq 50\%$ of the maximum burn rate.

In your request, you state that the specification for determining the medium burn rate found in ASTM E2779-10 is incorrect, and the Medium Burn Rate Category should be defined as less than 50% of the midpoint point (this is defined in the attached Memo as 50% of the span between the Maximum Burn Rate and the Low Burn Rate) between the high and low burn rates. Furthermore, your request includes a memorandum dated February 2, 2022, titled “Appropriate Calculation of Medium Burn Rate Category in ASTM E-2779 Testing” (attached) which was sent to the EPA’s Office of Enforcement and Compliance Assurance. This memorandum states that an error had been uncovered in determining the appropriate Medium Burn Rate Category in ASTM E2779-10 for compliance pursuant to Subpart AAA. Specifically, section 9.4.1.2 of ASTM E2779-10 states that “the pellet heater shall be operated with the control or controls set in

the position(s) as needed to achieve a burn rate that is $\leq 50\%$ of the maximum burn rate.” Table 1 of ASTM E2779-10 also notes that the Medium Burn Rate Category test must be $\leq 50\%$ of the maximum burn rate. The memorandum states that this is incorrect as it assumes that zero is the other bound for determining half of the maximum burn rate, and that the correct approach in determining the Medium Burn Rate Category should be at a level below 50% of the span between the Maximum Burn Rate and the Low Burn Rate (a non-zero value).

We have reviewed your request and agree that the Medium Burn Rate Category should be defined as less than 50% of the span between the high and low burn rates. Meaning that the Medium Burn Rate Category should be at a level below 50% of the span between the Maximum Burn Rate and the Low Burn Rate (a non-zero value).

Based on the information provided and with the caveats set forth below, we are approving your request for an alternative methodology used when calculating the Medium Burn Rate Category to conduct certification testing as required by Subpart AAA, section 60.534(a)(1)(i) on pellet heaters. This approval is based on the understanding that the Medium Burn Rate Category is defined as less than 50% of the span between the high and low burn rates. Additionally, this approval is based on the understanding that the lowest heat output (Btu/hr) setting available to the user, and corresponds to the lowest burn rate to be evaluated during certification testing; this is consistent with Subpart AAA, section 60.534(a)(1), which states: “The burn rate for the low burn category must be no greater than the rate that an operator can achieve in home use and no greater than is advertised by the manufacturer or retailer.”

With this Alternate Test Method, the following changes to ASTM E2779-10 must be followed for certification testing:

1. Medium Burn Rate Category burn rate is defined as:

Nomenclature:

Max = Maximum burn rate (kg/h)

Min = Minimum burn rate (kg/h)

$$\frac{Max+Min}{2} \quad \text{Eq.1}$$

All other requirements of ASTM E-2779-10 must be followed during the testing, and all requirements of 40 CFR part 60, Subpart AAA must be satisfied as described in your test report. A copy of this letter must be included in each certification test report where this alternative test method is utilized.

Because this alternative method may be of use to others, we feel that it is reasonable that this approval be broadly applicable to all pellet heaters tested in accordance with ASTM E2779-10 “Standard Test Method for Determining Particulate Matter Emissions from Pellet Heaters” and subject to the requirements of §60.534(a)(1)(i) of Subpart AAA. For this reason, we will post this

letter as ALT-146 on our website at <https://www.epa.gov/emc/broadly-applicable-approved-alternative-test-methods> for use by other interested parties. This alternative method approval is valid until such time that Subpart AAA is revised or replaced to require a different pellet heater certification method, and at such time, this alternative will be reconsidered and possibly withdrawn.

If you have additional questions regarding this approval, please contact Angelina Brashear of my staff at 919-541-4746 or brashear.angelina@epa.gov.

Sincerely,

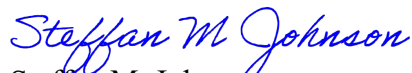

Steffan M. Johnson
Group Leader
Measurement Technology Group

cc: Angelina Brashear – EPA/OAQPS/AQAD
Chuck French – EPA/OAQPS/SPPD
Rafael Sanchez – EPA/OECA
Robert Scinta – EPA/OECA
Michael Toney – EPA/OAQPS/AQAD
Nathan Topham – EPA/OAQPS/SPPD
John Voorhees – United States Stove Company
Chet Wayland – EPA/OAQPS/AQAD



UNITED STATES ENVIRONMENTAL PROTECTION AGENCY
RESEARCH TRIANGLE PARK, NC 27711

OFFICE OF
AIR QUALITY PLANNING
AND STANDARDS

MEMORANDUM

02/02/2022

SUBJECT: Appropriate calculation of Medium Burn Rate Category in ASTM E-2779 Testing

FROM: Steffan Johnson
Group Leader
Measurement Technology Group
Air Quality Assessment Division

**STEFFAN
JOHNSON** Digitally signed by
STEFFAN JOHNSON
Date: 2022.02.02
08:28:07 -05'00'

TO: Robert Scinta, P.E.
Chief, Air Branch
Monitoring, Assistance, and Media Programs Division
Office of Compliance, Office of Enforcement and Compliance Assurance

During a recent review of pellet heater compliance test reports, the Measurement Technology Group has uncovered an error in determining the appropriate Medium Burn Rate Category when using ASTM E-2779 for compliance pursuant to 40 CFR 60, subpart AAA. Specifically, the method requirements in section 9.4.1.2 and Table 1 of that test method incorrectly require that the Medium Burn Rate Category must fall below 50% of the maximum burn rate. This is not correct as this requirement assumes then that zero is the other bound for determining half of the maximum.

9.4.1.2 *Medium Burn Rate Category*—For burn rates in the medium segment, except as allowed in 9.4.1.4 or 9.4.1.5, the pellet heater shall be operated with the control or controls set in the position(s) as needed to achieve a burn rate that is $\leq 50\%$ of the maximum burn rate.

TABLE 1

Burn Rate Segment	Maximum	Medium	Minimum
Description	Maximum achievable	$\leq 50\%$ of Maximum	Minimum achievable
Time at Burn Rate	60 +5 / - 0 minutes	120 +5 / - 0 minutes	180 +5 / - 0 minutes

The correct application of this requirement would be to determine the Medium Burn Rate Category at a level below 50% of the span between the Maximum Burn Rate and the Low Burn Rate (a non-zero value). Ergo, the correct calculation for finding that midpoint of 50% is defined as $\frac{Max+M}{2}$.

For example, if the Maximum Burn rate of an appliance is 1.79 kg/hr and the minimum is 1.23 kg/hr, the method would currently place the 50% requirement at 0.895 kg/hr. This is unachievable on this appliance and presents an impossible compliance requirement. Applying the equation laid out above the value of 1.51 is derived and, therefore, presents an appropriate and likely attainable emissions test requirement for the Medium Burn Rate Category.

During your reviews of such emissions tests, as reported to OECA and intended for compliance certification purposes, MTG recommends applying the above procedure in order to ascertain if a Medium Burn Rate was appropriately established during a compliance test.

CC:

Sarah Ayres - OECA

Angelina Brashear – OAQPS

Alice Edwards – Alaska DEC

Chuck French – OAQPS

Robert Lischinsky - OECA

Theresa Lowe - OAQPS

Rafael Sanchez – OECA

Robert Scinta - OECA

Mike Toney – OAQPS

Nathan Topham - OAQPS

Chet Wayland – OAQPS

Equations and Sample Calculations – ASTM E2779 & E2515

Client Laminox
 Model: Phenix
 Tracking #: 163
 Run: 1

Equations used to calculate the parameters listed below are described in this appendix. Sample calculations are provided for each equation. The raw data and printout results from a sample run are also provided for comparison to the sample calculations.

M_{Bdb} – Weight of test fuel burned during test run, dry basis, kg

M_{BSidb} – Weight of test fuel burned during test run segment i , dry basis, kg

BR – Average dry burn rate over full integrated test run, kg/hr

BR_{Si} – Average dry burn rate over test run segment i , kg/hr

V_s – Average gas velocity in the dilution tunnel, ft/sec

Q_{sd} – Average gas flow rate in dilution tunnel, dscf/hr

$V_{m(std)}$ – Volume of Gas Sampled Corrected to Dry Standard Conditions, dscf

m_n – Total Particulate Matter Collected, mg

C_s - Concentration of particulate matter in tunnel gas, dry basis, corrected to STP, g/dscf

E_T – Total Particulate Emissions, g

PR - Proportional Rate Variation

PM_R – Average particulate emissions for full integrated test run, g/hr

PM_F – Average particulate emission factor for full integrated test run, g/dry kg of fuel burned

M_{Bdb} – Weight of test fuel burned during test run, dry basis, kg

ASTM E2779 equation (1)

$$M_{Bdb} = (M_{Swb} - M_{Ewb})(100/(100 + FM))$$

Where,

FM = average fuel moisture of test fuel, % dry basis

M_{Swb} = weight of test fuel in hopper at start of test run, wet basis, kg

M_{Ewb} = weight of test fuel in hopper at end of test run, wet basis, kg

Sample Calculation:

$$FM = 2.61 \%$$

$$M_{Swb} = 17.3 \text{ lbs}$$

$$M_{Ewb} = 0.0 \text{ lbs}$$

0.4536 = Conversion factor from lbs to kg

$$M_{Bdb} = [(17.3 \times 0.4536) - (0.0 \times 0.4536)] (100/(100 + 2.606))$$

$$M_{Bdb} = 7.67 \text{ kg}$$

M_{BSidb} – Weight of test fuel burned during test run segment i , dry basis, kg

ASTM E2779 equation (2)

$$M_{BSidb} = (M_{SSiwb} - M_{ESiwb})(100/(100 + FM))$$

Where,

M_{SSiwb} = weight of test fuel in hopper at start of test run segment i , wet basis, kg

M_{ESiwb} = weight of test fuel in hopper at end of test run segment i , wet basis, kg

Sample Calculation (from medium burn rate segment):

$$FM = 2.61 \%$$

$$M_{SSiwb} = 12.1 \text{ lbs}$$

$$M_{ESiwb} = 6.4 \text{ lbs}$$

0.4536 = Conversion factor from lbs to kg

$$M_{BSidb} = [(12.1 \times 0.4536) - (6.4 \times 0.4536)] (100/(100 + 2.61))$$

$$M_{BSidb} = 2.52 \text{ kg}$$

BR – Average dry burn rate over full integrated test run, kg/hr

ASTM E2779 equation (3)

$$BR = \frac{60 M_{Bdb}}{\theta}$$

Where,

$$\theta = \text{Total length of full integrated test run, min}$$

Sample Calculation:

$$M_{Bdb} = 7.67 \quad \text{kg}$$

$$\theta = 360 \quad \text{min}$$

$$BR = \frac{60 \times 7.67}{360}$$

$$BR = 1.28 \quad \text{kg/hr}$$

BR_{Si} – Average dry burn rate over test run segment *i*, kg/hr

ASTM E2779 equation (4)

$$BR_{Si} = \frac{60 M_{BSidb}}{\theta_{Si}}$$

Where,

$$\theta_{Si} = \text{Total length of test run segment } i, \text{ min}$$

Sample Calculation (from medium burn rate segment):

$$M_{BSidb} = 2.52 \text{ kg}$$

$$\theta = 120 \text{ min}$$

$$BR = \frac{60 \times 2.52}{120}$$

$$BR = 1.26 \text{ kg/hr}$$

V_s – Average gas velocity in the dilution tunnel, ft/sec

ASTM E2515 equations (9)

$$V_s = F_p \times K_p \times C_p \times (\sqrt{\Delta P})_{avg} \times \sqrt{\frac{T_s}{P_s \times M_s}}$$

Where:

- F_p = Adjustment factor for center of tunnel pitot tube placement, F_p = $\frac{V_{strav}}{V_{scent}}$, ASTM E2515 Equation (1)
- V_{scent} = Dilution tunnel velocity calculated after the multi-point pitot traverse at the center, ft/sec
- V_{strav} = Dilution tunnel velocity calculated after the multi-point pitot traverse, ft/sec
- k_p = Pitot tube constant, 85.49
- C_p = Pitot tube coefficient: 0.99, unitless
- ΔP* = Velocity pressure in the dilution tunnel, in H₂O
- T_s = Absolute average gas temperature in the dilution tunnel, °R; (°R = °F + 460)
- P_s = Absolute average gas static pressure in dilution tunnel, = P_{bar} + P_g, in Hg
- P_{bar} = Barometric pressure at test site, in. Hg
- P_g = Static pressure of tunnel, in. H₂O; (in Hg = in H₂O/13.6)
- M_s = **The dilution tunnel wet molecular weight; M_s = 28.78 assuming a dry weight of 29 lb/lb-mole

Sample calculation:

$$F_p = \frac{7.62}{8.97} = 0.850$$

$$V_s = 0.850 \times 85.49 \times 0.99 \times 0.132 \times \left(\frac{96.8 + 460}{29.82 + \frac{-0.01}{13.6}} \right)^{1/2} \times 28.78$$

$$V_s = 7.64 \text{ ft/s}$$

*The ASTM test standard mistakenly has the square root of the average delta p instead of the average of the square root of delta p. The current EPA Method 2 is also incorrect. This was verified by Mike Toney at EPA.

**The ASTM test standard mistakenly identifies M_s as the dry molecular weight. It should be the wet molecular weight as indicated in EPA Method 2.

Q_{sd} – Average gas flow rate in dilution tunnel, dscf/hr

ASTM E2515 equation (3)

$$Q_{sd} = 3600 \times (1 - B_{ws}) \times v_s \times A \times \frac{T_{std}}{T_s} \times \frac{P_s}{P_{std}}$$

Where:

- 3600 = Conversion from seconds to hours (ASTM method uses 60 to convert in minutes)
- B_{ws} = Water vapor in gas stream, proportion by volume; assume 2%
- A = Cross sectional area of dilution tunnel, ft²
- T_{std} = Standard absolute temperature, 528 °R
- P_s = Absolute average gas static pressure in dilution tunnel, = P_{bar} + P_g, in Hg
- T_s = Absolute average gas temperature in the dilution tunnel, °R; (°R = °F + 460)
- P_{std} = Standard absolute pressure, 29.92 in Hg

Sample calculation:

$$Q_{sd} = 3600 \times (1 - 0.02) \times 7.64 \times 0.7854 \times \frac{528}{96.8 + 460} \times \frac{29.82 + \frac{-0.01}{13.6}}{29.92}$$

Q_{sd} = **20010.9** dscf/hr

$V_{m(std)}$ – Volume of Gas Sampled Corrected to Dry Standard Conditions, dscf
 ASTM E2515 equation (6)

$$V_{m(std)} = K_1 \times V_m \times Y \times \frac{P_{bar} + \left(\frac{\Delta H}{13.6} \right)}{T_m}$$

Where:

- K_1 = 17.64 °R/in. Hg
- V_m = Volume of gas sample measured at the dry gas meter, dcf
- Y = Dry gas meter calibration factor, dimensionless
- P_{bar} = Barometric pressure at the testing site, in. Hg
- ΔH = Average pressure differential across the orifice meter, in. H₂O
- T_m = Absolute average dry gas meter temperature, °R

Sample Calculation:

Using equation for Train A:

$$V_{m(std)} = 17.64 \times 56.932 \times 1.004 \times \frac{\left(29.82 + \frac{2.43}{13.6} \right)}{\left(96.6 + 460 \right)}$$

$$V_{m(std)} = \mathbf{54.340} \text{ dscf}$$

Using equation for Train B:

$$V_{m(std)} = 17.64 \times 55.545 \times 1.004 \times \frac{\left(29.82 + \frac{2.38}{13.6} \right)}{\left(95.5 + 460 \right)}$$

$$V_{m(std)} = \mathbf{53.115} \text{ dscf}$$

Using equation for ambient train:

$$V_{m(std)} = 17.64 \times 31.22 \times 1.003 \times \frac{\left(\underline{29.82} + \frac{0.00}{13.6} \right)}{\left(72.1 + 460 \right)}$$

$$V_{m(std)} = \mathbf{30.958} \text{ dscf}$$

m_n – Total Particulate Matter Collected, mg

ASTM E2515 Equation (12)

$$m_n = m_p + m_f + m_g$$

Where:

m_p = mass of particulate matter from probe, mg

m_f = mass of particulate matter from filters, mg

m_g = mass of particulate matter from filter seals, mg

Sample Calculation:

Using equation for Train A:

$$m_n = 0.9 + 1.5 + 1.3$$

$$m_n = \mathbf{3.7} \text{ mg}$$

Using equation for Train B:

$$m_n = 1.0 + 1.9 + 0.9$$

$$m_n = \mathbf{3.8} \text{ mg}$$

C_s - Concentration of particulate matter in tunnel gas, dry basis, corrected to standard conditions, g/dscf
 ASTM E2515 equation (13)

$$C_s = K_2 \times \frac{m_n}{V_{m(\text{std})}}$$

Where:

- K₂ = Constant, 0.001 g/mg
 m_n = Total mass of particulate matter collected in the sampling train, mg
 V_{m(std)} = Volume of gas sampled corrected to dry standard conditions, dscf

Sample calculation:

For Train A:

$$C_s = 0.001 \times \frac{3.7}{54.340}$$

$$C_s = \mathbf{0.00007} \text{ g/dscf}$$

For Train B:

$$C_s = 0.001 \times \frac{3.8}{53.115}$$

$$C_s = \mathbf{0.00007} \text{ g/dscf}$$

For Ambient Train

$$C_r = 0.001 \times \frac{0.2}{30.958}$$

$$C_r = \mathbf{0.000006} \text{ g/dscf}$$

E_T – Total Particulate Emissions, g

ASTM E2515 equation (15)

$$E_T = (C_s - C_r) \times Q_{std} \times \theta$$

Where:

- C_s = Concentration of particulate matter in tunnel gas, g/dscf
- C_r = Concentration particulate matter room air, g/dscf
- Q_{std} = Average dilution tunnel gas flow rate, dscf/hr
- θ = Total time of test run, minutes

Sample calculation:

For Train A

$$E_T = (0.000068 - 0.000006) \times 20010.9 \times 360 /60$$

$$E_T = \mathbf{7.40} \text{ g}$$

For Train B

$$E_T = (0.000072 - 0.000006) \times 20010.9 \times 360 /60$$

$$E_T = \mathbf{7.81} \text{ g}$$

Average

$$E = \mathbf{7.61} \text{ g}$$

Total emission values shall not differ by more than 7.5% from the total average emissions

- 7.5% of the average = 0.57
- Train A difference (%) = **2.7%**
- Train B difference (%)= **2.7%**

PR - Proportional Rate Variation

ASTM E2515 equation (16)

$$PR = \left[\frac{\theta \times V_{mi} \times V_s \times T_m \times T_{si}}{\theta_i \times V_m \times V_{si} \times T_{mi} \times T_s} \right] \times 100$$

Where:

- θ = Total sampling time, min
- θ_i = Length of recording interval, min
- V_{mi} = Volume of gas sample measured by the dry gas meter during the "ith" time interval, dcf
- V_m = Volume of gas sample as measured by dry gas meter, dcf
- V_{si} = Average gas velocity in the dilution tunnel during the "ith" time interval, ft/sec
- V_s = Average gas velocity in the dilution tunnel, ft/sec
- T_{mi} = Absolute average dry gas meter temperature during the "ith" time interval, °R
- T_m = Absolute average dry gas meter temperature, °R
- T_{si} = Absolute average gas temperature in the dilution tunnel during the "ith" time interval, °R
- T_s = Absolute average gas temperature in the dilution tunnel, °R

Sample calculation (for the first 10 minute interval of Train A):

$$PR = \left(\frac{360 \times 1.421 \times 7.64 \times (96.6 + 460) \times (#### + 460)}{10 \times 56.932 \times 7.58 \times (96.8 + 460) \times (72.8 + 460)} \right) \times 100$$

PR = **95** %

PM_R – Average particulate emissions for full integrated test run, g/hr
ASTM E2779 equation (5)

$$PM_R = 60 (E_T/\theta)$$

Where,

E_T = Total particulate emissions, grams

θ = Total length of full integrated test run, min

Sample Calculation:

$$E_T \text{ (Dual train average)} = 7.61 \text{ g}$$

$$\theta = 360 \text{ min}$$

$$PM_R = 60 \times (7.61 / 360)$$

$$PM_R = 1.27 \text{ g/hr}$$

PM_F – Average particulate emission factor for full integrated test run, g/dry kg of fuel burned
ASTM E2779 equation (6)

$$PM_F = E_T / M_{Bdb}$$

Where,

E_T = Total particulate emissions, grams

M_{Bdb} = Weight of test fuel burned during test run, dry basis, kg

Sample Calculation:

$$E_T \text{ (Dual train average)} = 7.61 \text{ g}$$

$$M_{Bdb} = 7.67 \text{ kg}$$

$$PM_F = 7.61 / 7.67)$$

$$PM_F = \mathbf{0.99} \text{ g/kg}$$

Stack Loss Efficiency and CO emissions calculations are done in accordance with CSA B415.1, using the password protected excel spreadsheet provided with the test standard. No alterations or alternative calculations are used for determining efficiency or CO emissions. The following pages are a sample of the calculations page from the B415.1 Spreadsheet (V2_4 - Dated April 15, 2010).

Manufacturer: Laminox
 Model: Phenix
 Date: 10/16/23
 Run: 1
 Control #: 23-209
 Test Duration: 360 min

Note: In the "Input data", "Calc. % O₂", "Fuel Properties", and "Mass Balance" columns, [e], [d], [g], [a], [b], [c], [h], [u], [w], [j], and [k] refer to their respective variables in Clauses 13.7.3 to 13.7.5.

	HHV	LHV
Eff	78.77%	87.14%
Comb Eff	99.50%	99.50%
HT Eff	79.16%	87.58%
Output	20,361	kJ/h
Burn Rate	1.28	kg/h
Grams CO	30	g
Input	25,849	kJ/h
MC wet	2.54	
Averages	0.03	7.59

Ultimate CO₂
 CO_{2,ult} 17.78
 F₀
 1.172

		Air Fuel Ratio (A/F)		
Overall Heating Efficiency:	78.77%	Dry Molecular Weight (M _D):	29.69	
Combustion Efficiency:	99.50%	Dry Moles Exhaust Gas (N _D):	558.04	%HC
Heat Transfer Efficiency:	79.16%	Air Fuel Ratio (A/F)	16.06	0.8
Heat Output:	19,315 Btu/h	20,361 kJ/h		
Heat Input:	24,521 Btu/h	25,849 kJ/h		
Burn Duration:	6.00	h		
Burn Rate:	2.82	lb/h	1.278	kg/h
Stack Temp:	292.6	Deg. F	144.8	Deg. C

Elapsed Time	INPUT DATA			Oxygen Calculation					Input Data		Combust Eff %	Heat Transfer %	Net Eff %	Air Fuel Ratio	Wet Wt Now	% Wet Consumed	Dry Wt. Now	% Dry Consumed	Total Input	Carbon /12= [a]
	Weight Remaining (kg)	% CO [e]	% CO ₂ [d]	Excess Air EA	Total O ₂	Calc. % O ₂ [g]	Flue Gas (°C)	Room Temp (°C)	Wt	x										
0	7.87	0.03	13.24	34.0%	18.59	5.33	185.1	20.5	100.0%	81.1%	81.1%	8.8	7.87	0.00	7.67	0.00	0	3.93		
1	7.83	0.02	12.15	46.2%	18.78	6.62	187.1	20.5	100.1%	80.4%	80.5%	9.6	7.83	0.52	7.63	0.52	1207	3.93		
2	7.79	0.09	14.02	26.0%	18.44	4.37	188.2	20.3	99.6%	81.4%	81.0%	8.3	7.79	1.04	7.59	1.04	760	3.93		
3	7.75	0.03	12.22	45.2%	18.77	6.53	188.6	20.4	100.0%	80.4%	80.4%	9.5	7.75	1.50	7.55	1.50	671	3.93		
4	7.72	0.03	11.39	55.7%	18.91	7.51	188.1	20.6	100.0%	79.8%	79.8%	10.2	7.72	1.90	7.52	1.90	671	3.93		
5	7.68	0.02	8.97	97.8%	19.34	10.37	186.4	20.5	100.2%	77.7%	77.8%	12.9	7.68	2.36	7.49	2.36	805	3.93		
6	7.64	0.09	14.80	19.4%	18.30	3.45	186.9	20.6	99.6%	81.8%	81.4%	7.9	7.64	2.94	7.44	2.94	894	3.93		
7	7.59	0.04	13.91	27.4%	18.46	4.53	186.3	20.6	99.8%	81.4%	81.3%	8.4	7.59	3.52	7.40	3.52	894	3.93		
8	7.55	0.11	14.19	24.4%	18.40	4.16	187.0	20.6	99.5%	81.5%	81.1%	8.2	7.55	4.09	7.35	4.09	894	3.93		
9	7.50	0.02	12.92	37.4%	18.64	5.71	188.1	20.7	100.0%	80.8%	80.8%	9.0	7.50	4.67	7.31	4.67	850	3.93		
10	7.46	0.11	14.66	20.5%	18.32	3.61	188.0	20.7	99.5%	81.7%	81.2%	7.9	7.46	5.19	7.27	5.19	671	3.93		
11	7.43	0.02	11.20	58.6%	18.95	7.74	188.9	20.7	100.1%	79.6%	79.7%	10.4	7.43	5.54	7.24	5.54	626	3.93		
12	7.40	0.02	10.88	63.1%	19.00	8.11	188.8	20.7	100.1%	79.4%	79.5%	10.7	7.40	6.00	7.21	6.00	805	3.93		
13	7.35	0.03	12.86	38.0%	18.65	5.78	187.7	20.7	100.0%	80.8%	80.8%	9.1	7.35	6.57	7.16	6.57	760	3.93		
14	7.32	0.02	11.42	55.4%	18.91	7.48	187.2	20.7	100.1%	79.9%	80.0%	10.2	7.32	6.98	7.13	6.98	626	3.93		
15	7.29	0.02	9.67	83.6%	19.22	9.54	187.4	20.8	100.2%	78.4%	78.5%	12.0	7.29	7.38	7.10	7.38	760	3.93		
16	7.24	0.05	14.61	21.3%	18.34	3.71	187.0	20.8	99.8%	81.7%	81.6%	8.0	7.24	7.96	7.06	7.96	805	3.93		
17	7.21	0.02	12.91	37.5%	18.65	5.73	186.9	20.7	100.0%	80.9%	80.9%	9.1	7.21	8.42	7.02	8.42	805	3.93		
18	7.16	0.03	12.76	39.0%	18.67	5.89	187.9	20.8	99.9%	80.7%	80.7%	9.1	7.16	9.00	6.98	9.00	850	3.93		
19	7.12	0.06	13.54	30.8%	18.53	4.96	188.1	20.8	99.8%	81.1%	81.0%	8.6	7.12	9.52	6.94	9.52	760	3.93		
20	7.08	0.02	12.35	43.7%	18.74	6.38	187.7	20.8	100.0%	80.5%	80.5%	9.4	7.08	9.98	6.90	9.98	716	3.93		
21	7.05	0.02	10.39	70.8%	19.09	8.69	187.4	20.8	100.1%	79.1%	79.2%	11.2	7.05	10.44	6.87	10.44	760	3.93		
22	7.01	0.02	12.77	39.0%	18.67	5.89	188.9	20.8	100.0%	80.7%	80.7%	9.1	7.01	10.96	6.83	10.96	850	3.93		
23	6.96	0.02	13.03	36.3%	18.62	5.59	188.3	20.9	100.0%	80.9%	80.9%	9.0	6.96	11.53	6.78	11.53	894	3.93		
24	6.91	0.10	14.49	21.8%	18.35	3.80	188.9	20.9	99.5%	81.6%	81.1%	8.0	6.91	12.11	6.74	12.11	850	3.93		
25	6.87	0.04	14.04	26.3%	18.44	4.38	189.1	20.9	99.9%	81.4%	81.2%	8.3	6.87	12.63	6.70	12.63	760	3.93		
26	6.84	0.02	11.11	59.8%	18.96	7.85	188.7	21.0	100.1%	79.6%	79.7%	10.5	6.84	13.09	6.66	13.09	671	3.93		
27	6.81	0.02	9.13	94.4%	19.32	10.18	188.3	20.9	100.2%	77.8%	77.9%	12.7	6.81	13.49	6.63	13.49	760	3.93		
28	6.76	0.16	15.01	17.2%	18.25	3.16	187.0	21.0	99.2%	81.9%	81.2%	7.7	6.76	14.07	6.59	14.07	850	3.93		
29	6.72	0.02	12.81	38.6%	18.66	5.84	188.5	21.1	100.0%	80.8%	80.8%	9.1	6.72	14.59	6.55	14.59	716	3.93		
30	6.69	0.02	12.71	39.7%	18.68	5.96	188.6	21.2	100.0%	80.7%	80.7%	9.2	6.69	14.99	6.52	14.99	760	3.93		
31	6.64	0.03	13.24	34.0%	18.58	5.33	188.4	21.1	99.9%	81.0%	80.9%	8.8	6.64	15.57	6.47	15.57	939	3.93		
32	6.59	0.37	15.58	11.5%	18.11	2.34	188.9	21.1	98.1%	82.0%	80.4%	7.3	6.59	16.21	6.43	16.21	805	3.93		

Moisture Content M_{cwb} : 2.54

Combustion Efficiency: 99.50%
 Total Input (kJ): 155,096 147,101 (Btu)
 Total Output (kJ): 122,167 115,870 (Btu)
 Efficiency: 78.77%
 Total CO (g): 30.47

Moisture of Wood (wet basis): 2.54
 Initial Dry Weight $W_{t_{db}}$ (kg): 7.67
 Moisture Content Dry 2.61

Dry kg : 7.67
 CA: 47
 HY: 9
 OX: 43.6

Load Weight (kg): 7.87
 Fuel Heating HHV LHV
 Value in kJ/kg - CV: 20,227 18,285 Btu/lb HHV LHV 8702.0 7866.2

9.01	2.73	20227.28	2.54	80.40	21.33	1.93	8.74	-0.02	0.19	39.37	74.15	0.15	-0.11	462.31	45.37	1.45	418.06	4899.95	3680.96	3577.84	3538.53
Fuel Properties			Mw Moisture Fuel Burnt	Mass Balance (moles/100 mole dry flue gas)					kg Wood per 100 mole dwp	Moles per kg of Dry Wood						Moisture Present	Stack Temp K	Heat Content Change - Ambient to Stack T			
Hydrogen /1= [b]	Oxygen /16= [c]	Calorific Value																Flue Gas Constituent			
				[h]	[u]	[w]	[j]	[k]		CO ₂	O ₂	CO	HC	N ₂	H ₂ O			CO ₂	O ₂	CO	N ₂
9.01	2.73	20227.28	2.54	81.40	21.59	3.37	15.20	-0.01	0.34	39.34	15.84	0.08	-0.02	241.87	45.17	1.45	458.21	6654.94	4963.88	4816.08	4764.99
9.01	2.73	20227.28	2.54	81.21	21.54	3.09	13.94	-0.01	0.31	39.39	21.47	0.05	-0.03	263.27	45.21	1.45	460.21	6740.65	5025.71	4875.55	4823.94
9.01	2.73	20227.28	2.54	81.52	21.62	3.59	16.16	0.01	0.36	39.13	12.19	0.25	0.02	227.51	45.10	1.45	461.37	6797.05	5066.69	4915.05	4863.08
9.01	2.73	20227.28	2.54	81.22	21.54	3.11	14.04	-0.01	0.31	39.35	21.02	0.08	-0.03	261.48	45.19	1.45	461.71	6807.13	5073.74	4921.76	4869.75
9.01	2.73	20227.28	2.54	81.07	21.50	2.90	13.09	-0.01	0.29	39.34	25.92	0.09	-0.03	279.95	45.21	1.45	461.21	6781.44	5055.00	4903.69	4851.84
9.01	2.73	20227.28	2.54	80.64	21.39	2.28	10.31	-0.02	0.23	39.37	45.52	0.10	-0.07	354.13	45.28	1.45	459.54	6712.07	5005.09	4855.72	4804.29
9.01	2.73	20227.28	2.54	81.66	21.66	3.79	17.05	0.01	0.38	39.15	9.13	0.23	0.02	216.00	45.10	1.45	460.04	6729.28	5017.28	4867.39	4815.87
9.01	2.73	20227.28	2.54	81.52	21.62	3.55	15.99	0.00	0.35	39.29	12.78	0.12	0.00	230.16	45.15	1.45	459.43	6703.08	4998.39	4849.22	4797.85
9.01	2.73	20227.28	2.54	81.54	21.63	3.64	16.37	0.01	0.36	39.08	11.45	0.29	0.03	224.55	45.08	1.45	460.15	6734.04	5020.72	4870.69	4819.14
9.01	2.73	20227.28	2.54	81.35	21.58	3.29	14.83	-0.01	0.33	39.36	17.40	0.07	-0.02	247.81	45.18	1.45	461.21	6777.21	5051.73	4900.49	4848.68
9.01	2.73	20227.28	2.54	81.63	21.65	3.76	16.90	0.01	0.37	39.08	9.63	0.29	0.03	217.68	45.08	1.45	461.15	6772.71	5048.38	4897.23	4845.46
9.01	2.73	20227.28	2.54	81.04	21.50	2.85	12.86	-0.01	0.28	39.38	27.23	0.06	-0.04	285.03	45.22	1.45	462.04	6812.98	5077.51	4925.28	4873.26
9.01	2.73	20227.28	2.54	80.99	21.48	2.77	12.50	-0.01	0.28	39.37	29.34	0.07	-0.04	292.98	45.23	1.45	461.93	6808.21	5074.07	4921.97	4869.98
9.01	2.73	20227.28	2.54	81.33	21.57	3.28	14.77	-0.01	0.33	39.34	17.67	0.08	-0.02	248.78	45.18	1.45	460.82	6760.52	5039.70	4888.92	4837.22
9.01	2.73	20227.28	2.54	81.08	21.51	2.91	13.12	-0.01	0.29	39.38	25.78	0.06	-0.04	279.53	45.22	1.45	460.32	6739.08	5024.24	4874.05	4822.47
9.01	2.73	20227.28	2.54	80.77	21.42	2.46	11.11	-0.02	0.25	39.39	38.89	0.07	-0.06	329.09	45.26	1.45	460.59	6746.76	5029.56	4879.11	4827.50
9.01	2.73	20227.28	2.54	81.64	21.65	3.73	16.79	0.00	0.37	39.28	9.96	0.12	0.00	219.50	45.14	1.45	460.15	6727.70	5015.81	4865.89	4814.40
9.01	2.73	20227.28	2.54	81.35	21.58	3.29	14.82	-0.01	0.33	39.37	17.46	0.05	-0.02	248.07	45.19	1.45	460.09	6727.43	5015.73	4865.84	4814.34
9.01	2.73	20227.28	2.54	81.32	21.57	3.25	14.66	-0.01	0.32	39.33	18.15	0.10	-0.02	250.56	45.18	1.45	461.04	6765.83	5043.30	4892.33	4840.61
9.01	2.73	20227.28	2.54	81.45	21.60	3.46	15.58	0.00	0.35	39.24	14.37	0.16	0.00	236.03	45.14	1.45	461.26	6775.37	5050.18	4898.94	4847.16
9.01	2.73	20227.28	2.54	81.25	21.55	3.14	14.18	-0.01	0.31	39.37	20.33	0.06	-0.03	258.93	45.20	1.45	460.82	6756.30	5036.43	4885.72	4834.05
9.01	2.73	20227.28	2.54	80.90	21.46	2.64	11.94	-0.01	0.26	39.39	32.93	0.07	-0.05	306.56	45.24	1.45	460.59	6746.76	5029.56	4879.11	4827.50
9.01	2.73	20227.28	2.54	81.32	21.57	3.25	14.66	-0.01	0.32	39.36	18.14	0.06	-0.02	250.62	45.19	1.45	462.04	6806.64	5072.61	4920.48	4868.51
9.01	2.73	20227.28	2.54	81.37	21.58	3.32	14.95	-0.01	0.33	39.37	16.88	0.06	-0.02	245.88	45.18	1.45	461.43	6778.29	5052.06	4900.70	4848.91
9.01	2.73	20227.28	2.54	81.60	21.64	3.71	16.71	0.01	0.37	39.09	10.26	0.28	0.03	220.10	45.08	1.45	462.04	6804.53	5070.97	4918.87	4866.93
9.01	2.73	20227.28	2.54	81.54	21.63	3.58	16.13	0.00	0.36	39.29	12.27	0.11	0.00	228.24	45.15	1.45	462.26	6814.07	5077.85	4925.49	4873.49
9.01	2.73	20227.28	2.54	81.03	21.49	2.83	12.76	-0.01	0.28	39.39	27.82	0.06	-0.04	287.25	45.23	1.45	461.87	6793.14	5062.54	4910.72	4858.86
9.01	2.73	20227.28	2.54	80.67	21.40	2.32	10.49	-0.02	0.23	39.40	43.93	0.08	-0.07	348.19	45.28	1.45	461.43	6776.18	5050.43	4899.10	4847.33
9.01	2.73	20227.28	2.54	81.67	21.66	3.86	17.36	0.02	0.39	38.92	8.19	0.43	0.06	211.81	45.02	1.45	460.15	6719.24	5009.27	4859.49	4808.08
9.01	2.73	20227.28	2.54	81.33	21.57	3.26	14.70	-0.01	0.33	39.38	17.96	0.05	-0.03	249.98	45.19	1.45	461.65	6779.37	5052.40	4900.90	4849.14
9.01	2.73	20227.28	2.54	81.31	21.57	3.23	14.59	-0.01	0.32	39.36	18.47	0.07	-0.02	251.87	45.19	1.45	461.71	6779.64	5052.48	4900.96	4849.20
9.01	2.73	20227.28	2.54	81.40	21.59	3.37	15.21	0.00	0.34	39.32	15.83	0.10	-0.01	241.75	45.17	1.45	461.59	6776.98	5050.68	4899.25	4847.50
9.01	2.73	20227.28	2.54	81.71	21.67	4.07	18.23	0.06	0.41	38.34	5.75	0.92	0.15	201.02	44.85	1.45	462.04	6796.07	5064.43	4912.47	4860.61

4731.41		4280.95		295.42		SUMS					4199.53		SUMS														
69625.13		90573.88		15708.50		561765.86		-37096.65		790233.89		25219.84		31813.14		-340.48		32153.6		123419.8		-336.0		30.5		-11.7	
emperature		Room Temp		Energy Losses (KJ/kg of Dry Fuel)										Total Loss	Total Loss	Chemical Loss 1	Sensible and Latent Loss	Total Output	Chem Loss 2	Grams Produced							
CH ₄	H ₂ O	K	CO ₂	O ₂	CO	N ₂	CH ₄	H ₂ O Comb	H ₂ O Fuel MC	Rate	Total Loss	Chemical Loss 1	Sensible and Latent Loss	Total Output	Chem Loss 2	CO	HC										
6503.72	5759.74	293.65	261.83	78.63	22.23	1152.52	-15.08	2246.44	72.00	3818.57	0.00	0	0.00	0	0	0.00	0.00										
6592.09	5830.69	293.65	265.50	107.91	14.00	1270.00	-29.11	2251.21	72.10	3951.60	235.90	-1	236.80	972	-1	0.08	-0.03										
6649.57	5877.85	293.48	265.99	61.77	72.31	1106.38	18.03	2248.10	72.17	3844.74	144.51	3	141.17	616	3	0.26	0.01										
6660.46	5885.84	293.59	267.86	106.67	23.17	1273.32	-23.43	2253.07	72.18	3972.84	131.76	0	131.77	539	0	0.07	-0.01										
6634.43	5864.26	293.71	266.81	131.00	26.84	1358.27	-29.80	2252.80	72.15	4078.08	135.25	0	135.35	536	0	0.09	-0.02										
6562.61	5807.04	293.65	264.27	227.85	29.07	1701.34	-62.05	2253.79	72.07	4486.34	178.55	-1	179.86	626	-1	0.11	-0.04										
6580.84	5820.94	293.76	263.46	45.82	66.25	1040.24	19.99	2245.31	72.09	3753.17	165.96	4	162.21	728	4	0.28	0.02										
6553.82	5799.26	293.76	263.34	63.89	34.95	1104.26	-3.04	2246.89	72.06	3782.35	167.25	1	165.87	727	1	0.15	0.00										
6585.76	5824.88	293.76	263.17	57.46	84.82	1082.13	26.02	2244.82	72.10	3830.51	169.38	5	164.55	725	5	0.36	0.02										
6630.55	5860.42	293.82	266.74	87.90	19.29	1201.53	-19.33	2251.46	72.15	3879.75	162.98	0	162.99	687	0	0.08	-0.01										
6626.14	5856.53	293.87	264.71	48.59	82.92	1054.77	28.10	2246.02	72.14	3797.24	125.93	4	122.31	545	4	0.27	0.02										
6667.48	5890.00	293.82	268.30	138.28	18.23	1389.05	-36.68	2254.73	72.19	4104.10	127.04	-1	127.61	499	-1	0.05	-0.02										
6662.55	5886.05	293.82	268.07	148.88	20.83	1426.80	-38.88	2254.79	72.19	4152.69	165.27	-1	165.99	640	-1	0.08	-0.03										
6613.32	5846.62	293.82	265.99	89.04	22.89	1203.40	-17.85	2250.67	72.13	3886.27	146.07	0	145.89	614	0	0.08	-0.01										
6591.19	5828.88	293.82	265.41	129.50	16.87	1348.03	-34.92	2251.77	72.10	4048.77	125.32	-1	125.88	501	-1	0.05	-0.02										
6599.60	5834.90	293.93	265.77	195.58	21.11	1588.71	-55.01	2254.27	72.11	4342.54	163.22	-1	164.49	597	-1	0.08	-0.04										
6579.94	5819.13	293.93	264.27	49.98	34.83	1056.75	1.70	2247.26	72.09	3726.87	148.32	1	146.89	657	1	0.13	0.00										
6579.42	5819.08	293.87	264.88	87.57	15.80	1194.28	-21.30	2249.81	72.09	3863.13	153.74	0	153.97	651	0	0.06	-0.02										
6619.28	5850.67	293.93	266.08	91.54	27.50	1212.84	-16.20	2250.67	72.13	3904.56	164.03	0	163.57	686	0	0.11	-0.01										
6629.13	5858.56	293.93	265.89	72.55	45.89	1144.06	0.13	2249.22	72.15	3849.88	144.70	2	143.00	616	2	0.17	0.00										
6609.44	5842.78	293.93	266.01	102.41	17.43	1251.68	-25.33	2251.33	72.12	3935.64	139.23	0	139.51	576	0	0.06	-0.02										
6599.60	5834.90	293.93	265.73	165.60	19.64	1479.90	-45.63	2253.23	72.11	4210.57	158.26	-1	159.24	602	-1	0.07	-0.03										
6661.66	5884.24	293.98	267.93	92.03	18.63	1220.16	-20.95	2252.72	72.18	3902.71	163.95	0	164.05	686	0	0.08	-0.02										
6632.63	5860.63	294.04	266.85	85.29	16.53	1192.23	-19.93	2251.54	72.15	3864.66	170.89	0	171.05	724	0	0.07	-0.02										
6659.72	5882.32	294.04	266.02	52.01	80.76	1071.19	25.86	2247.43	72.18	3815.46	160.28	4	155.87	689	4	0.33	0.02										
6669.57	5890.21	294.04	267.74	62.31	33.04	1112.34	-3.19	2251.01	72.19	3795.45	142.66	1	141.56	618	1	0.12	0.00										
6648.45	5872.57	294.15	267.56	140.82	17.35	1395.69	-38.14	2254.10	72.17	4109.55	136.29	-1	136.98	535	-1	0.06	-0.02										
6630.69	5858.71	294.09	266.96	221.89	22.37	1687.79	-62.95	2256.23	72.15	4464.43	167.80	-2	169.33	592	-2	0.08	-0.04										
6572.17	5811.45	294.15	261.52	41.03	122.43	1018.42	51.77	2241.36	72.08	3808.60	159.99	7	152.78	690	7	0.50	0.04										
6634.71	5860.85	294.26	266.95	90.75	15.04	1212.17	-22.57	2251.84	72.15	3886.33	137.48	0	137.75	578	0	0.05	-0.01										
6635.23	5860.90	294.32	266.84	93.34	19.62	1221.35	-20.98	2251.67	72.15	3903.98	146.74	0	146.80	614	0	0.07	-0.01										
6632.25	5858.87	294.26	266.46	79.93	28.22	1171.89	-11.85	2250.56	72.15	3857.36	179.10	1	178.36	760	1	0.13	-0.01										
6651.95	5874.65	294.26	260.55	29.13	264.21	977.08	132.05	2235.28	72.17	3970.47	158.02	16	142.46	647	16	1.02	0.09										



Twin Ports Testing, Inc.
 1301 North 3rd Street
 Superior, WI 54880
 p: 715-392-7114
 p: 800-373-2562
 f: 715-392-7163
 www.twinportstesting.com

Report No: USR:W223-0426-01
Issue No: 2
Revised Report. Previous report is USR:W223-0426-01 issue number 1

Analytical Test Report

Client: PFS-TECO
 11785 SE Hwy 212 Ste 305
 Clackamas, OR 97015
Attention: Sebastian Button
PO No:

Signed: *Katy Jahr*
 Katy Jahr
 Chemistry Lab Supervisor
 Date of Issue: 8/23/2023
 THIS DOCUMENT SHALL NOT BE REPRODUCED EXCEPT IN FULL

Sample Details
Sample Log No: W223-0426-01 **Sample Date:**
Sample Designation: Pellets **Sample Time:**
Sample Recognized As: **Arrival Date:** 8/1/2023

	METHOD	UNITS	MOISTURE		AS RECEIVED
			FREE		
Moisture Total	ASTM E871	wt. %			2.54
Ash	ASTM D1102	wt. %	0.20		0.19
Volatile Matter	ASTM D3175	wt. %			
Fixed Carbon by Difference	ASTM D3172	wt. %			
Sulfur	ASTM D4239	wt. %	0.009		0.009
SO ₂	Calculated	lb/mmbtu			0.020
Net Cal. Value at Const. Pressure	ISO 1928	GJ/tonne	18.29		17.77
Gross Cal. Value at Const. Vol.	ASTM E711	Btu/lb	8702		8481
Carbon	ASTM D5373	wt. %	47.19		46.00
Hydrogen*	ASTM D5373	wt. %	9.01		8.79
Nitrogen	ASTM D5373	wt. %	< 0.20	<	0.20
Oxygen*	ASTM D3176	wt. %	> 43.39	>	42.29
*Note: As received values do not include hydrogen and oxygen in the total moisture.					
Chlorine	ASTM D6721	mg/kg			
Fluorine	ASTM D3761	mg/kg			
Mercury	ASTM D6722	mg/kg			
Bulk Density	ASTM E873	lbs/ft ³			
Fines (Less than 1/8")	TPT CH-P-06	wt. %			
Durability Index	Kansas State	PDI			
Sample Above 1.50"	TPT CH-P-06	wt. %			
Maximum Length (Single Pellet)	TPT CH-P-06	inch			
Diameter, Range	TPT CH-P-05	inch			to
Diameter, Average	TPT CH-P-05	inch			
Stated Bag Weight	TPT CH-P-01	lbs			
Actual Bag Weight	TPT CH-P-01	lbs			

Comments:



Accreditation #60243

Results issued on this report only reflect the analysis of the sample submitted. Our reports and letters are for the exclusive and confidential use of our clients and may not be reproduced, except in their entirety, without the written approval of Twin Ports Testing. Twin Ports Testing Laboratory is accredited to the ISO/IEC 17025:2017 standard by PJLA.

Pre-Conditioning Data

Client: Laminox	Job #: 23-209
Model: Phenix	Tracking #: 163
Date(s): 10/11/23 - 10/13/23	Technician: AK

Elapsed Time (hrs)	Flue (°F)	Catalyst Exit (°F)	Notes: Indicate initial air setting and any changes in in setting during conditioning, as well as weight and average moisture content of all fuel additions.
0	152		+26.6 lb, Golden Fire premium pellets; air medium
1	350		
2	347		
3	337		
4	339		
5	346		
6	319		+28.1 lb, Golden Fire premium pellets; air medium
7	287		
8	277		
9	283		
10	276		
11	279		
12	283		
13	279		
14	282		
15	282		
16	280		
17	276		
18	285		
19	282		
20	273		
21	286		
22	287		
23	314		+45.5 lb, Golden Fire premium pellets; air medium
24	302		
25	311		
26	295		
27	296		
28	293		
29	293		
30	286		+21.3 lb, Golden Fire premium pellets; air medium
31	284		
32	298		
33	290		
34	294		
35	292		
36	289		
37	293		
38	285		
39	279		
40	283		
41	284		
42	274		
43	295		
44	280		
45	279		
46	288		
47	275		
48	270		
49	268		
50	260		

PELLET TEST DATA PACKET
ASTM E2779/E2515



Run 1 Data Summary

Client: Laminox
Model: Phenix
Job #: 23-209
Tracking #: 163
Test Date: 10/16/2023



Technician Signature

11/22/2023

Date

TEST RESULTS - ASTM E2779 / ASTM E2515

Client: Laminox
 Model: Phenix
 Run #: 1

Job #: 23-209
 Tracking #: 163
 Technician: AK
 Date: 10/16/2023

Burn Rate Summary	
High Burn Rate (dry kg/hr)	2.30
Medium Burn Rate (dry kg/hr)	1.26
Low Burn Rate (dry kg/hr)	0.95
Overall Burn Rate (dry kg/hr)	1.28

Medium Burn Rate Target: < 1.62 dry kg/hr

	Ambient Sample	Sample Train A	Sample Train B	1st Hour Filter - Train C
Total Sample Volume (ft ³)	31.222	56.932	55.545	8.867
Average Gas Velocity in Dilution Tunnel (ft/sec)	7.6			
Average Gas Flow Rate in Dilution Tunnel (dscf/hr)	20010.9			
Average Gas Meter Temperature (°F)	72.1	96.6	95.5	75.9
Total Sample Volume (dscf)	30.958	54.340	53.115	8.821
Average Tunnel Temperature (°F)	96.8			
Total Time of Test (min)	360			
Total Particulate Catch (mg)	0.2	3.7	3.8	2.2
Particulate Concentration, dry-standard (g/dscf)	0.0000065	0.0000681	0.0000715	0.0002494
Total PM Emissions (g)	0.78	7.40	7.81	4.86
Particulate Emission Rate (g/hr)	0.13	1.23	1.30	4.86
Emissions Factor (g/kg)	-	0.97	1.02	2.11
Difference from Average Total Particulate Emissions (g)	-	0.21	0.21	-
Difference from Average Total Particulate Emissions (%)	-	2.7%	2.7%	-
Difference from Average Emissions Factor (g/kg)	-	0.03	0.03	-

Final Average Results	
Total Particulate Emissions (g)	7.61
Particulate Emission Rate (g/hr)	1.27
Emissions Factor (g/kg)	0.99
HHV Efficiency (%)	78.8%
LHV Efficiency (%)	87.1%
CO Emissions (g/min)	0.08

Quality Checks	Requirement	Observed	Result
Dual Train Precision	Each train within 7.5% of average emissions (in grams), or emission factors within 0.5 g/kg	See Above	OK
Filter Temps	<90 °F	83.8	OK
Face Velocity	< 30 ft/min	8.8	OK
Leakage Rate	Less than 4% of average sample rate	0 cfm	OK
Ambient Temp	55-90 °F	68.6 / 74.5	OK
Negative Probe Weight Evaluation	<5% of Total Catch	Probe Catch Not Negative	OK
Pro-Rate Variation	90% of readings between 90-110%; none greater than 120% or less than 80%	See Data Tabs	OK
Medium Burn Rate	< midpoint of the high and low burn rates	1.26	OK

Overall Pellet Test Efficiency Results

Manufacturer: Laminox
Model: Phenix
Date: 10/16/23
Run: 1
Control #: 23-209
Test Duration: 360
Output Category: Integrated

Test Results in Accordance with CSA B415.1-10

	HHV Basis	LHV Basis
Overall Efficiency	78.8%	87.1%
Combustion Efficiency	99.5%	99.5%
Heat Transfer Efficiency	79.2%	87.6%

Output Rate (kJ/h)	20,361	19,315	(Btu/h)
Burn Rate (kg/h)	1.28	2.82	(lb/h)
Input (kJ/h)	25,849	24,521	(Btu/h)

Test Load Weight (dry kg)	7.67	16.90	dry lb
MC wet (%)	2.54		
MC dry (%)	2.61		
Particulate (g)	7.61		
CO (g)	30		
Test Duration (h)	6.00		

Emissions	Particulate	CO
g/MJ Output	0.06	0.25
g/kg Dry Fuel	0.99	3.97
g/h	1.27	5.08
g/min	0.02	0.08
lb/MM Btu Output	0.14	0.58

Air/Fuel Ratio (A/F)	16.06
-----------------------------	-------

VERSION:

2.4

4/15/2010

Max Burn Rate Segment Efficiency Results

Manufacturer: Laminox
Model: Phenix
Date: 10/16/23
Run: 1
Control #: 23-209
Test Duration: 60
Output Category: Maximum

Test Results in Accordance with CSA B415.1-10

	HHV Basis	LHV Basis
Overall Efficiency	80.0%	88.5%
Combustion Efficiency	99.5%	99.5%
Heat Transfer Efficiency	80.4%	88.9%

Output Rate (kJ/h)	37,193	35,281	(Btu/h)
Burn Rate (kg/h)	2.30	5.07	(lb/h)
Input (kJ/h)	46,511	44,121	(Btu/h)

Test Load Weight (dry kg)	2.30	5.07	dry lb
MC wet (%)	2.54		
MC dry (%)	2.61		
Particulate (g)	N/A		
CO (g)	8		
Test Duration (h)	1.00		

Emissions	Particulate	CO
g/MJ Output	N/A	0.21
g/kg Dry Fuel	N/A	3.40
g/h	N/A	7.82
g/min	N/A	0.13
lb/MM Btu Output	N/A	0.49

Air/Fuel Ratio (A/F)	9.60
-----------------------------	------

VERSION:

2.4

4/15/2010

Medium Burn Rate Segment Efficiency Results

Manufacturer: Laminox
Model: Phenix
Date: 10/16/23
Run: 1
Control #: 23-209
Test Duration: 120
Output Category: Medium

Test Results in Accordance with CSA B415.1-10

	HHV Basis	LHV Basis
Overall Efficiency	78.1%	86.4%
Combustion Efficiency	99.5%	99.5%
Heat Transfer Efficiency	78.5%	86.9%

Output Rate (kJ/h)	19,915	18,891	(Btu/h)
Burn Rate (kg/h)	1.26	2.78	(lb/h)
Input (kJ/h)	25,492	24,182	(Btu/h)

Test Load Weight (dry kg)	2.52	5.56	dry lb
MC wet (%)	2.54		
MC dry (%)	2.61		
Particulate (g)	N/A		
CO (g)	9		
Test Duration (h)	2.00		

Emissions	Particulate	CO
g/MJ Output	N/A	0.23
g/kg Dry Fuel	N/A	3.62
g/h	N/A	4.56
g/min	N/A	0.08
lb/MM Btu Output	N/A	0.53

Air/Fuel Ratio (A/F)	16.08
-----------------------------	-------

VERSION:

2.4

4/15/2010

Minimum Burn Rate Segment Efficiency Results

Manufacturer: Laminox
Model: Phenix
Date: 10/16/23
Run: 1
Control #: 23-209
Test Duration: 180
Output Category: Minimum

Test Results in Accordance with CSA B415.1-10

	HHV Basis	LHV Basis
Overall Efficiency	78.2%	86.5%
Combustion Efficiency	99.5%	99.5%
Heat Transfer Efficiency	78.6%	87.0%

Output Rate (kJ/h)	15,017	14,245	(Btu/h)
Burn Rate (kg/h)	0.95	2.09	(lb/h)
Input (kJ/h)	19,201	18,214	(Btu/h)

Test Load Weight (dry kg)	2.85	6.28	dry lb
MC wet (%)	2.54		
MC dry (%)	2.61		
Particulate (g)	N/A		
CO (g)	13		
Test Duration (h)	3.00		

Emissions	Particulate	CO
g/MJ Output	N/A	0.30
g/kg Dry Fuel	N/A	4.73
g/h	N/A	4.49
g/min	N/A	0.07
lb/MM Btu Output	N/A	0.69

Air/Fuel Ratio (A/F)	20.65
-----------------------------	-------

VERSION:

2.4

4/15/2010

DILUTION TUNNEL & MISC. DATA - ASTM E2779 / E2515

Client: **Laminox**
 Model: **Phenix**
 Run #: **1**
 Test Start Time: **10:05**

Job #: **23-209**
 Tracking #: **163**
 Technician: **AK**
 Date: **10/16/2023**

High Burn End Time (min): **60**
 Medium Burn End Time (min): **180**
 Total Sampling Time (min): **360**
 Recording Interval (min): **1**

Meter Box γ Factor: **1.004 (A)**
 Meter Box γ Factor: **1.004 (B)**
 Meter Box γ Factor: **1.011 (C)**
 Meter Box γ Factor: **1.003 (Ambient)**
 Induced Draft Check (in. H₂O): **0**
 Smoke Capture Check (%): **100%**
 Date Flue Pipe Last Cleaned: **10/13/2023**
 Platform Scale Audit (lbs) **10.0**

	Pre-Test	Post Test	Avg.
Barometric Pressure (in. Hg)	29.82	29.82	29.82
Relative Humidity (%)	58.2	51.7	
Room Air Velocity (ft/min)	<50	<50	
Pitot Tube Leak Check	0	0	
Ambient Sample Volume:	31.222 ft³		

Sample Train Leak Checks

	Pre-test	Post-test		
(A)	0.000	0.000	cfm @	-5 in. Hg
(B)	0.000	0.000	cfm @	-5 in. Hg
(C)	0.000	0.000	cfm @	-6 in. Hg
(Ambient)	0.000	0.000	cfm @	-12 in. Hg

DILUTION TUNNEL FLOW

Traverse Data

Point	dP (in H ₂ O)	Temp (°F)
1	0.010	73
2	0.014	73
3	0.014	73
4	0.016	73
5	0.014	73
6	0.008	74
7	0.010	74
8	0.014	74
9	0.014	74
10	0.018	74
11	0.014	75
12	0.012	75
Center	0.018	75

Dilution Tunnel H₂O: **2.00** percent
 Tunnel Diameter: **12** inches
 Pitot Tube C_p: **0.99** [unitless]
 Dilution Tunnel MW(dry): **29.00** lb/lb-mole
 Dilution Tunnel MW(wet): **28.78** lb/lb-mole
 Tunnel Area: **0.7854** ft²

V_{strav}: **7.618** ft/sec
 V_{scent}: **8.965** ft/sec
 F_p: **0.850** [ratio]

Initial Tunnel Flow: **346.8** scf/min

Static Pressure: **-0.010** in. H₂O

TEST FUEL PROPERTIES

Default Fuel Values

Fuel Type:	D. Fir	Oak
HHV (kJ/kg)	19,810	19,887
%C	48.73	50
%H	6.87	6.6
%O	43.9	42.9
%Ash	0.5	0.5

Actual Fuel Used Properties

Pellet Brand:	Golden Fire
Pellet Fuel Grade:	PFI Premium
HHV (BTU/lb)	8702
%C	47.19
%H	9.01
%O	43.6
%Ash	0.2
MC (%WB)	2.54

PELLET STOVE PREBURN DATA - ASTM E2779

Client: <u>Laminox</u>	Job #: <u>23-209</u>
Model: <u>Phenix</u>	Tracking #: <u>163</u>
Run #: <u>1</u>	Technician: <u>AK</u>
	Date: <u>10/16/2023</u>

Recording Interval (min): 1
 Run Time (min): 62

Elapsed Time (min)	Scale Reading (lbs)	Average:			
		Weight Change (lbs)	Flue Draft (in H ₂ O)	Flue (°F)	Ambient (°F)
			-0.044	291	67
0	43.7	-	-0.015	117	66
1	43.7	-0.03	-0.014	124	66
2	43.7	-0.04	-0.016	133	66
3	43.6	-0.05	-0.019	143	66
4	43.6	-0.06	-0.022	153	66
5	43.5	-0.05	-0.025	162	66
6	43.4	-0.07	-0.025	169	66
7	43.4	-0.05	-0.025	174	66
8	43.3	-0.06	-0.027	180	66
9	43.3	-0.04	-0.029	187	66
10	43.2	-0.05	-0.030	195	66
11	43.2	-0.07	-0.031	205	66
12	43.1	-0.04	-0.033	209	66
13	43.1	-0.04	-0.033	213	66
14	43.1	-0.04	-0.032	216	66
15	43.0	-0.04	-0.033	218	66
16	43.0	-0.06	-0.037	224	66
17	42.8	-0.11	-0.037	240	66
18	42.8	-0.08	-0.038	251	66
19	42.7	-0.07	-0.040	259	67
20	42.6	-0.07	-0.042	265	67
21	42.5	-0.08	-0.042	274	67
22	42.5	-0.09	-0.043	281	67
23	42.4	-0.06	-0.044	287	67
24	42.4	-0.03	-0.043	294	67
25	42.3	-0.08	-0.044	297	67
26	42.2	-0.07	-0.045	302	67
27	42.1	-0.07	-0.046	306	67
28	42.1	-0.09	-0.046	308	67
29	42.0	-0.07	-0.048	314	67
30	41.9	-0.09	-0.049	319	67
31	41.8	-0.09	-0.048	325	67
32	41.7	-0.08	-0.050	330	67
33	41.6	-0.1	-0.050	334	67
34	41.5	-0.09	-0.050	339	67
35	41.5	-0.07	-0.050	340	67
36	41.4	-0.08	-0.052	342	68
37	41.3	-0.09	-0.051	345	68
38	41.2	-0.07	-0.052	347	68
39	41.1	-0.08	-0.052	347	68
40	41.1	-0.09	-0.054	349	68
41	41.0	-0.08	-0.052	348	68
42	40.9	-0.09	-0.053	350	68
43	40.8	-0.08	-0.054	352	68
44	40.7	-0.1	-0.052	356	68
45	40.6	-0.09	-0.054	357	68
46	40.5	-0.09	-0.054	359	68

PELLET STOVE PREBURN DATA - ASTM E2779

Client: Laminox Job #: 23-209
Model: Phenix Tracking #: 163
Run #: 1 Technician: AK
Date: 10/16/2023

47	40.5	-0.07	-0.054	358	68
48	40.4	-0.05	-0.055	357	68
49	40.3	-0.09	-0.054	356	68
50	40.2	-0.1	-0.054	359	69
51	40.1	-0.09	-0.053	362	69
52	40.0	-0.08	-0.053	364	68
53	40.0	-0.07	-0.052	361	69
54	39.9	-0.08	-0.054	360	69
55	39.8	-0.09	-0.054	361	69
56	39.7	-0.09	-0.054	360	69
57	39.6	-0.08	-0.055	359	68
58	39.5	-0.1	-0.056	362	69
59	39.4	-0.1	-0.053	364	69
60	39.4	-0.08	-0.055	366	69
61	39.3	-0.08	-0.055	367	69
62	39.2	-0.1	-0.056	365	69

BOX A TEST DATA - ASTM E2779 / ASTM E2515

Client: Laminox
 Model: Phenix
 Run #: 1

Job #: 23-209
 Tracking #: 163
 Technician: AK
 Date: 10/16/2023

Elapsed Time (min)	Particulate Sampling Data							Fuel Weight (lb)		Temperature Data (°F)			
	Gas Meter (ft ³)	Sample Rate (cfm)	Dilution Tunnel dP (in H ₂ O)	Orifice dH (in H ₂ O)	Meter Temp (°F)	Meter Vacuum (in Hg)	Pro. Rate (%)	Scale Reading	Weight Change	Dilution Tunnel	Flue	Filter	Ambient
0	0.000		0.018	1.31	72.2	0.76		17.3		100	365	70	68.9
1	0.100	0.100	0.017	2.10	72.1	0.84	-	17.3	-0.1	101	369	72	68.6
2	0.246	0.146	0.018	2.15	72.1	0.82	-	17.2	-0.1	101	371	73	68.8
3	0.389	0.143	0.017	2.17	72.1	0.84	-	17.1	-0.1	101	371	73	69
4	0.534	0.145	0.018	2.18	72.1	0.83	-	17.0	-0.1	101	371	74	68.9
5	0.682	0.148	0.018	2.21	72.2	0.88	-	16.9	-0.1	101	368	74	69.1
6	0.828	0.146	0.018	2.24	72.3	0.85	-	16.8	-0.1	101	368	74	69.1
7	0.978	0.150	0.017	2.25	72.4	0.88	-	16.7	-0.1	102	367	75	69.1
8	1.124	0.146	0.018	2.27	72.5	0.86	-	16.6	-0.1	101	369	75	69.2
9	1.274	0.150	0.017	2.28	72.7	0.86	-	16.5	-0.1	101	371	75	69.3
10	1.421	0.147	0.017	2.29	72.8	0.86	94	16.4	-0.1	101	370	75	69.2
11	1.573	0.152	0.017	2.30	73	0.86	-	16.4	-0.1	102	372	76	69.2
12	1.720	0.147	0.017	2.32	73.2	0.87	-	16.3	-0.1	102	372	76	69.2
13	1.873	0.153	0.018	2.33	73.4	0.87	-	16.2	-0.1	102	370	76	69.2
14	2.021	0.148	0.018	2.34	73.6	0.89	-	16.1	-0.1	102	369	76	69.4
15	2.174	0.153	0.017	2.35	73.9	0.86	-	16.1	-0.1	102	369	76	69.4
16	2.323	0.149	0.017	2.35	74.1	0.88	-	16.0	-0.1	102	369	77	69.3
17	2.477	0.154	0.018	2.36	74.4	0.88	-	15.9	-0.1	101	369	77	69.4
18	2.625	0.148	0.018	2.36	74.7	0.9	-	15.8	-0.1	102	370	77	69.4
19	2.779	0.154	0.017	2.36	75	0.88	-	15.7	-0.1	102	371	77	69.4
20	2.929	0.150	0.017	2.36	75.3	0.9	101	15.6	-0.1	102	370	77	69.4
21	3.082	0.153	0.017	2.37	75.6	0.9	-	15.5	-0.1	102	369	77	69.5
22	3.234	0.152	0.018	2.37	76	0.89	-	15.4	-0.1	102	372	78	69.6
23	3.386	0.152	0.018	2.38	76.3	0.93	-	15.3	-0.1	103	371	78	69.6
24	3.540	0.154	0.017	2.39	76.6	0.91	-	15.2	-0.1	102	372	78	69.6
25	3.692	0.152	0.017	2.39	76.9	0.92	-	15.2	-0.1	103	372	78	69.8
26	3.847	0.155	0.018	2.40	77.3	0.91	-	15.1	-0.1	103	372	78	69.7
27	3.998	0.151	0.018	2.40	77.6	0.92	-	15.0	-0.1	103	371	78	69.8
28	4.154	0.156	0.018	2.40	77.9	0.95	-	14.9	-0.1	103	369	78	70
29	4.304	0.150	0.017	2.40	78.3	0.94	-	14.8	-0.1	103	371	78	70.1
30	4.460	0.156	0.018	2.40	78.5	0.94	101	14.7	-0.1	103	371	78	70
31	4.611	0.151	0.018	2.41	78.9	0.97	-	14.6	-0.1	103	371	78	70
32	4.769	0.158	0.018	2.41	79.2	0.94	-	14.5	-0.1	103	372	79	70

BOX A TEST DATA - ASTM E2779 / ASTM E2515

Client: Laminox
 Model: Phenix
 Run #: 1

Job #: 23-209
 Tracking #: 163
 Technician: AK
 Date: 10/16/2023

Elapsed Time (min)	Particulate Sampling Data							Fuel Weight (lb)		Temperature Data (°F)			
	Gas Meter (ft ³)	Sample Rate (cfm)	Dilution Tunnel dP (in H ₂ O)	Orifice dH (in H ₂ O)	Meter Temp (°F)	Meter Vacuum (in Hg)	Pro. Rate (%)	Scale Reading	Weight Change	Dilution Tunnel	Flue	Filter	Ambient
33	4.919	0.150	0.018	2.41	79.6	0.93	-	14.5	-0.1	104	372	79	70
34	5.076	0.157	0.017	2.43	79.9	0.94	-	14.4	-0.1	104	371	79	69.7
35	5.228	0.152	0.018	2.41	80.3	0.95	-	14.3	-0.1	104	368	79	69.9
36	5.383	0.155	0.017	2.41	80.7	0.96	-	14.2	-0.1	103	369	79	70.1
37	5.538	0.155	0.017	2.42	81	0.95	-	14.1	-0.1	103	371	79	70
38	5.692	0.154	0.017	2.43	81.3	0.95	-	14.0	-0.1	103	372	79	70.2
39	5.849	0.157	0.017	2.42	81.7	0.97	-	14.0	-0.1	103	372	79	70.4
40	6.000	0.151	0.018	2.42	82	0.97	99	13.9	-0.1	104	371	79	70.2
41	6.159	0.159	0.018	2.43	82.3	0.99	-	13.8	-0.1	104	374	79	70.2
42	6.311	0.152	0.017	2.42	82.7	0.97	-	13.7	-0.1	104	372	79	70.4
43	6.470	0.159	0.017	2.43	83	0.98	-	13.6	-0.1	104	371	79	70.4
44	6.622	0.152	0.018	2.42	83.3	0.95	-	13.5	-0.1	103	374	79	70.3
45	6.779	0.157	0.017	2.43	83.6	0.98	-	13.4	-0.1	104	371	79	70.3
46	6.933	0.154	0.017	2.43	83.9	0.99	-	13.3	-0.1	103	371	79	70.2
47	7.090	0.157	0.017	2.44	84.2	0.98	-	13.3	-0.1	103	369	79	70.1
48	7.248	0.158	0.017	2.45	84.5	0.99	-	13.2	-0.1	103	372	79	70.2
49	7.400	0.152	0.017	2.44	84.8	0.99	-	13.1	-0.1	103	371	80	70.3
50	7.558	0.158	0.017	2.42	85.2	1	101	13.0	-0.1	103	369	80	70.4
51	7.712	0.154	0.017	2.44	85.4	1	-	12.9	-0.1	103	368	80	70.2
52	7.872	0.160	0.017	2.44	85.7	1	-	12.8	-0.1	103	370	80	70.3
53	8.025	0.153	0.017	2.43	86	1	-	12.7	-0.1	103	372	80	70.5
54	8.181	0.156	0.017	2.44	86.3	1	-	12.7	-0.1	103	372	80	70.2
55	8.340	0.159	0.017	2.45	86.6	1.02	-	12.6	-0.1	103	372	80	70.4
56	8.495	0.155	0.017	2.45	86.8	0.99	-	12.5	-0.1	103	371	80	70.3
57	8.652	0.157	0.017	2.45	87.1	1.02	-	12.4	-0.1	104	372	80	70.2
58	8.806	0.154	0.017	2.43	87.4	1.02	-	12.3	-0.1	104	374	80	70.5
59	8.967	0.161	0.017	2.44	87.6	1.03	-	12.2	-0.1	104	372	80	70.4
60	9.120	0.153	0.017	2.45	87.8	1.02	102	12.1	-0.1	104	371	80	70.6
61	9.278	0.158	0.016	2.46	88	1.03	-	12.1	0.0	104	375	80	70.7
62	9.434	0.156	0.018	2.45	88.3	1.03	-	12.0	-0.1	103	372	80	70.4
63	9.591	0.157	0.017	2.46	88.5	1.01	-	12.0	-0.1	103	370	80	70.4
64	9.750	0.159	0.017	2.46	88.7	1.02	-	11.9	-0.1	102	367	80	70.3
65	9.903	0.153	0.017	2.46	89	1.04	-	11.8	0.0	102	363	80	70.6

BOX A TEST DATA - ASTM E2779 / ASTM E2515

Client: Laminox
 Model: Phenix
 Run #: 1

Job #: 23-209
 Tracking #: 163
 Technician: AK
 Date: 10/16/2023

Elapsed Time (min)	Particulate Sampling Data							Fuel Weight (lb)		Temperature Data (°F)			
	Gas Meter (ft ³)	Sample Rate (cfm)	Dilution Tunnel dP (in H ₂ O)	Orifice dH (in H ₂ O)	Meter Temp (°F)	Meter Vacuum (in Hg)	Pro. Rate (%)	Scale Reading	Weight Change	Dilution Tunnel	Flue	Filter	Ambient
66	10.064	0.161	0.018	2.46	89.2	1.01	-	11.8	-0.1	102	359	80	70.7
67	10.219	0.155	0.017	2.47	89.5	1.03	-	11.7	-0.1	101	358	80	70.6
68	10.377	0.158	0.018	2.47	89.7	1.03	-	11.7	-0.1	101	355	80	70.7
69	10.535	0.158	0.018	2.46	89.9	1.05	-	11.6	0.0	101	353	80	70.7
70	10.691	0.156	0.017	2.47	90.2	1.03	102	11.5	-0.1	101	354	80	70.6
71	10.850	0.159	0.018	2.45	90.4	1.04	-	11.5	-0.1	100	349	80	70.5
72	11.004	0.154	0.017	2.47	90.5	1.03	-	11.4	0.0	101	343	80	70.6
73	11.166	0.162	0.017	2.47	90.7	1.05	-	11.4	-0.1	100	339	80	70.6
74	11.320	0.154	0.017	2.47	90.9	1.06	-	11.3	0.0	100	337	80	70.7
75	11.479	0.159	0.018	2.46	91.1	1.06	-	11.3	-0.1	99	336	80	70.8
76	11.639	0.160	0.017	2.47	91.3	1.04	-	11.2	-0.1	99	332	80	70.7
77	11.795	0.156	0.018	2.48	91.5	1.04	-	11.2	-0.1	99	333	80	70.6
78	11.955	0.160	0.017	2.46	91.7	1.04	-	11.1	0.0	99	330	80	70.5
79	12.111	0.156	0.017	2.47	91.9	1.03	-	11.1	-0.1	99	329	80	70.5
80	12.271	0.160	0.017	2.47	92.1	1.05	102	11.0	0.0	98	327	80	70.5
81	12.427	0.156	0.017	2.47	92.2	1.04	-	11.0	-0.1	98	324	80	70.6
82	12.587	0.160	0.017	2.48	92.4	1.05	-	10.9	-0.1	98	326	80	70.5
83	12.746	0.159	0.017	2.47	92.5	1.06	-	10.8	-0.1	98	326	80	70.7
84	12.901	0.155	0.018	2.46	92.7	1.07	-	10.8	0.0	98	325	80	70.7
85	13.064	0.163	0.017	2.48	92.9	1.07	-	10.8	-0.1	98	323	79	70.6
86	13.219	0.155	0.017	2.47	93.1	1.06	-	10.7	0.0	97	319	79	70.7
87	13.378	0.159	0.017	2.46	93.2	1.04	-	10.7	0.0	97	317	79	70.6
88	13.539	0.161	0.017	2.48	93.4	1.05	-	10.6	-0.1	97	319	79	70.7
89	13.695	0.156	0.017	2.48	93.5	1.05	-	10.6	0.0	97	317	79	70.6
90	13.856	0.161	0.017	2.47	93.6	1.05	102	10.5	-0.1	97	316	79	70.6
91	14.013	0.157	0.018	2.47	93.8	1.05	-	10.5	0.0	97	313	79	70.8
92	14.172	0.159	0.017	2.48	93.9	1.05	-	10.4	0.0	97	310	79	70.4
93	14.331	0.159	0.017	2.48	94.1	1.07	-	10.4	0.0	96	309	79	70.3
94	14.490	0.159	0.017	2.49	94.3	1.06	-	10.3	-0.1	96	308	79	70.4
95	14.650	0.160	0.017	2.47	94.4	1.07	-	10.3	0.0	97	308	79	70.4
96	14.806	0.156	0.017	2.48	94.5	1.07	-	10.2	0.0	96	309	79	70.4
97	14.968	0.162	0.017	2.48	94.6	1.05	-	10.2	0.0	96	305	79	70.6
98	15.125	0.157	0.017	2.49	94.7	1.06	-	10.2	0.0	96	304	79	70.6

BOX A TEST DATA - ASTM E2779 / ASTM E2515

Client: Laminox
 Model: Phenix
 Run #: 1

Job #: 23-209
 Tracking #: 163
 Technician: AK
 Date: 10/16/2023

Elapsed Time (min)	Particulate Sampling Data							Fuel Weight (lb)		Temperature Data (°F)			
	Gas Meter (ft ³)	Sample Rate (cfm)	Dilution Tunnel dP (in H ₂ O)	Orifice dH (in H ₂ O)	Meter Temp (°F)	Meter Vacuum (in Hg)	Pro. Rate (%)	Scale Reading	Weight Change	Dilution Tunnel	Flue	Filter	Ambient
99	15.285	0.160	0.017	2.48	94.9	1.07	-	10.1	-0.1	96	305	79	70.7
100	15.445	0.160	0.017	2.49	95	1.08	102	10.1	-0.1	96	307	79	70.7
101	15.600	0.155	0.017	2.48	95.1	1.05	-	10.0	0.0	96	305	79	70.7
102	15.764	0.164	0.017	2.48	95.2	1.05	-	10.0	0.0	96	305	79	70.6
103	15.919	0.155	0.017	2.48	95.3	1.05	-	9.9	-0.1	96	305	79	70.6
104	16.080	0.161	0.017	2.47	95.5	1.07	-	9.9	0.0	96	303	79	70.7
105	16.241	0.161	0.017	2.49	95.6	1.08	-	9.9	0.0	96	303	79	70.8
106	16.397	0.156	0.017	2.49	95.7	1.08	-	9.8	-0.1	95	300	79	70.8
107	16.560	0.163	0.017	2.49	95.8	1.05	-	9.8	0.0	95	297	79	70.6
108	16.716	0.156	0.017	2.49	95.9	1.06	-	9.7	0.0	95	297	79	70.7
109	16.876	0.160	0.017	2.48	95.9	1.07	-	9.7	-0.1	95	294	79	70.8
110	17.037	0.161	0.017	2.48	96.1	1.08	102	9.6	0.0	95	294	79	70.8
111	17.193	0.156	0.018	2.48	96.2	1.08	-	9.6	0.0	95	294	79	70.8
112	17.356	0.163	0.017	2.48	96.3	1.08	-	9.6	0.0	95	290	79	70.7
113	17.513	0.157	0.017	2.49	96.4	1.05	-	9.6	0.0	95	286	79	70.7
114	17.673	0.160	0.017	2.48	96.5	1.06	-	9.5	-0.1	95	289	79	70.7
115	17.833	0.160	0.017	2.48	96.6	1.08	-	9.4	-0.1	95	292	79	70.7
116	17.990	0.157	0.017	2.49	96.6	1.08	-	9.4	0.0	95	292	79	70.9
117	18.151	0.161	0.017	2.47	96.7	1.11	-	9.3	0.0	95	290	79	71
118	18.309	0.158	0.017	2.48	96.8	1.07	-	9.3	0.0	95	288	79	70.9
119	18.469	0.160	0.017	2.47	96.9	1.09	-	9.3	-0.1	95	289	79	70.9
120	18.629	0.160	0.017	2.47	96.9	1.11	102	9.2	-0.1	95	290	79	70.9
121	18.788	0.159	0.017	2.48	97	1.09	-	9.2	0.0	95	289	79	70.9
122	18.949	0.161	0.018	2.49	97.1	1.08	-	9.1	-0.1	95	287	79	70.9
123	19.106	0.157	0.017	2.49	97.2	1.09	-	9.1	0.0	95	287	79	70.9
124	19.268	0.162	0.017	2.50	97.2	1.08	-	9.0	0.0	95	287	79	70.9
125	19.427	0.159	0.017	2.48	97.3	1.09	-	9.0	-0.1	95	288	79	71
126	19.586	0.159	0.017	2.50	97.3	1.09	-	8.9	-0.1	95	289	79	71
127	19.747	0.161	0.017	2.49	97.5	1.09	-	8.9	-0.1	95	291	79	71
128	19.905	0.158	0.017	2.49	97.5	1.1	-	8.8	0.0	95	291	79	71
129	20.066	0.161	0.017	2.48	97.6	1.09	-	8.8	0.0	95	288	79	70.9
130	20.225	0.159	0.017	2.48	97.7	1.1	102	8.7	0.0	95	290	79	71
131	20.385	0.160	0.017	2.49	97.7	1.09	-	8.7	-0.1	95	293	79	71

BOX A TEST DATA - ASTM E2779 / ASTM E2515

Client: Laminox
 Model: Phenix
 Run #: 1

Job #: 23-209
 Tracking #: 163
 Technician: AK
 Date: 10/16/2023

Elapsed Time (min)	Particulate Sampling Data							Fuel Weight (lb)		Temperature Data (°F)			
	Gas Meter (ft ³)	Sample Rate (cfm)	Dilution Tunnel dP (in H ₂ O)	Orifice dH (in H ₂ O)	Meter Temp (°F)	Meter Vacuum (in Hg)	Pro. Rate (%)	Scale Reading	Weight Change	Dilution Tunnel	Flue	Filter	Ambient
132	20.546	0.161	0.017	2.49	97.8	1.07	-	8.7	0.0	95	291	79	71
133	20.703	0.157	0.017	2.48	97.9	1.1	-	8.6	0.0	95	289	79	71
134	20.865	0.162	0.017	2.50	97.9	1.12	-	8.6	-0.1	95	292	79	71.1
135	21.023	0.158	0.017	2.48	98	1.1	-	8.5	0.0	95	292	79	71.1
136	21.183	0.160	0.017	2.48	98.1	1.09	-	8.5	-0.1	95	293	79	71.1
137	21.344	0.161	0.017	2.49	98.1	1.07	-	8.4	0.0	95	293	79	71.2
138	21.501	0.157	0.017	2.49	98.2	1.1	-	8.4	0.0	95	291	79	71
139	21.664	0.163	0.017	2.49	98.3	1.12	-	8.4	0.0	95	288	79	71.2
140	21.821	0.157	0.017	2.48	98.4	1.09	102	8.3	0.0	95	287	79	71.4
141	21.982	0.161	0.017	2.48	98.4	1.09	-	8.3	0.0	95	287	79	71.3
142	22.142	0.160	0.017	2.48	98.5	1.1	-	8.2	-0.1	95	286	80	71.4
143	22.300	0.158	0.017	2.47	98.6	1.11	-	8.2	-0.1	95	288	80	71.5
144	22.463	0.163	0.017	2.49	98.6	1.11	-	8.1	-0.1	95	288	80	71.4
145	22.619	0.156	0.017	2.48	98.7	1.11	-	8.1	0.0	96	287	80	71.4
146	22.780	0.161	0.017	2.48	98.8	1.1	-	8.0	-0.1	95	288	80	71.3
147	22.941	0.161	0.017	2.48	98.8	1.09	-	8.0	-0.1	96	290	80	71.4
148	23.098	0.157	0.017	2.48	98.8	1.11	-	7.9	-0.1	96	290	80	71.4
149	23.262	0.164	0.017	2.48	98.9	1.12	-	7.9	-0.1	96	290	80	71.5
150	23.418	0.156	0.017	2.48	98.9	1.12	102	7.8	0.0	96	288	80	71.4
151	23.579	0.161	0.017	2.47	99	1.08	-	7.8	0.0	96	288	80	71.5
152	23.739	0.160	0.017	2.47	99	1.12	-	7.7	0.0	96	287	80	71.6
153	23.896	0.157	0.018	2.48	99.1	1.14	-	7.7	0.0	96	285	80	71.6
154	24.060	0.164	0.018	2.48	99.2	1.14	-	7.7	0.0	95	285	80	71.5
155	24.217	0.157	0.017	2.48	99.2	1.12	-	7.6	0.0	96	284	80	71.4
156	24.378	0.161	0.017	2.48	99.2	1.11	-	7.6	0.0	96	282	80	71.6
157	24.538	0.160	0.017	2.49	99.3	1.1	-	7.6	0.0	96	279	80	71.7
158	24.695	0.157	0.017	2.47	99.4	1.11	-	7.5	-0.1	96	282	80	71.7
159	24.859	0.164	0.017	2.48	99.4	1.13	-	7.4	-0.1	96	285	80	71.6
160	25.015	0.156	0.017	2.48	99.4	1.11	102	7.4	0.0	96	283	80	71.7
161	25.176	0.161	0.017	2.47	99.4	1.14	-	7.4	0.0	96	282	80	71.8
162	25.337	0.161	0.017	2.47	99.5	1.12	-	7.3	0.0	96	281	80	71.9
163	25.493	0.156	0.017	2.46	99.6	1.13	-	7.3	-0.1	95	283	80	71.9
164	25.657	0.164	0.017	2.48	99.7	1.12	-	7.2	0.0	95	282	80	71.8

BOX A TEST DATA - ASTM E2779 / ASTM E2515

Client: Laminox
 Model: Phenix
 Run #: 1

Job #: 23-209
 Tracking #: 163
 Technician: AK
 Date: 10/16/2023

Elapsed Time (min)	Particulate Sampling Data							Fuel Weight (lb)		Temperature Data (°F)			
	Gas Meter (ft ³)	Sample Rate (cfm)	Dilution Tunnel dP (in H ₂ O)	Orifice dH (in H ₂ O)	Meter Temp (°F)	Meter Vacuum (in Hg)	Pro. Rate (%)	Scale Reading	Weight Change	Dilution Tunnel	Flue	Filter	Ambient
165	25.814	0.157	0.017	2.47	99.7	1.16	-	7.2	0.0	96	281	80	71.9
166	25.975	0.161	0.017	2.47	99.8	1.12	-	7.1	-0.1	96	282	80	71.9
167	26.136	0.161	0.017	2.48	99.9	1.14	-	7.1	-0.1	96	285	80	71.8
168	26.292	0.156	0.017	2.47	99.9	1.14	-	7.0	-0.1	96	286	80	71.9
169	26.456	0.164	0.017	2.47	100.1	1.12	-	7.0	-0.1	96	287	80	71.8
170	26.612	0.156	0.017	2.48	100.1	1.14	102	6.9	-0.1	96	287	80	71.9
171	26.774	0.162	0.017	2.48	100.1	1.15	-	6.9	-0.1	96	290	80	71.9
172	26.935	0.161	0.017	2.47	100.1	1.14	-	6.8	-0.1	96	291	80	72
173	27.091	0.156	0.018	2.47	100.2	1.12	-	6.8	-0.1	96	290	80	72
174	27.255	0.164	0.017	2.47	100.3	1.13	-	6.7	0.0	96	290	80	72
175	27.411	0.156	0.017	2.48	100.3	1.13	-	6.7	-0.1	96	290	80	72.1
176	27.573	0.162	0.017	2.47	100.4	1.11	-	6.6	0.0	96	287	80	72
177	27.734	0.161	0.017	2.46	100.4	1.15	-	6.6	0.0	96	288	80	72
178	27.890	0.156	0.017	2.46	100.5	1.13	-	6.5	-0.1	96	290	80	72.1
179	28.054	0.164	0.017	2.47	100.5	1.12	-	6.5	-0.1	96	290	80	72
180	28.210	0.156	0.017	2.47	100.6	1.15	102	6.4	0.0	97	291	80	72.1
181	28.372	0.162	0.017	2.48	100.6	1.13	-	6.4	0.0	97	289	80	72.4
182	28.534	0.162	0.017	2.47	100.6	1.13	-	6.4	0.0	97	288	81	72.3
183	28.689	0.155	0.017	2.48	100.6	1.13	-	6.3	0.0	97	286	81	72.4
184	28.853	0.164	0.017	2.47	100.7	1.17	-	6.3	0.0	97	285	81	72.4
185	29.009	0.156	0.018	2.46	100.7	1.16	-	6.3	0.0	96	284	81	72.4
186	29.171	0.162	0.017	2.47	100.8	1.16	-	6.2	-0.1	96	282	81	72.4
187	29.333	0.162	0.017	2.48	100.7	1.12	-	6.2	0.0	96	279	81	72.5
188	29.489	0.156	0.017	2.47	100.8	1.17	-	6.2	0.0	96	276	81	72.5
189	29.652	0.163	0.017	2.46	100.9	1.15	-	6.1	0.0	96	274	81	72.5
190	29.809	0.157	0.018	2.48	100.9	1.13	100	6.1	0.0	96	274	81	72.6
191	29.970	0.161	0.017	2.46	100.9	1.15	-	6.0	0.0	96	273	81	72.6
192	30.132	0.162	0.017	2.46	100.9	1.15	-	6.0	0.0	96	270	80	72.5
193	30.288	0.156	0.018	2.45	101	1.13	-	6.0	0.0	96	269	81	72.4
194	30.452	0.164	0.017	2.45	101	1.14	-	5.9	0.0	95	269	81	72.6
195	30.608	0.156	0.018	2.45	101.1	1.16	-	5.9	0.0	96	269	81	72.7
196	30.770	0.162	0.017	2.45	101.2	1.16	-	5.9	0.0	96	267	81	72.6
197	30.931	0.161	0.018	2.47	101.2	1.13	-	5.8	0.0	95	269	81	72.4

BOX A TEST DATA - ASTM E2779 / ASTM E2515

Client: Laminox
 Model: Phenix
 Run #: 1

Job #: 23-209
 Tracking #: 163
 Technician: AK
 Date: 10/16/2023

Elapsed Time (min)	Particulate Sampling Data							Fuel Weight (lb)		Temperature Data (°F)			
	Gas Meter (ft ³)	Sample Rate (cfm)	Dilution Tunnel dP (in H ₂ O)	Orifice dH (in H ₂ O)	Meter Temp (°F)	Meter Vacuum (in Hg)	Pro. Rate (%)	Scale Reading	Weight Change	Dilution Tunnel	Flue	Filter	Ambient
198	31.087	0.156	0.017	2.46	101.2	1.17	-	5.8	0.0	95	266	81	72.3
199	31.251	0.164	0.017	2.45	101.3	1.14	-	5.8	0.0	95	264	81	72.4
200	31.407	0.156	0.017	2.46	101.3	1.12	100	5.7	0.0	95	265	81	72.4
201	31.568	0.161	0.017	2.45	101.4	1.14	-	5.7	0.0	95	264	81	72.4
202	31.730	0.162	0.018	2.46	101.4	1.15	-	5.7	0.0	95	263	81	72.5
203	31.886	0.156	0.018	2.46	101.5	1.17	-	5.6	0.0	95	262	81	72.6
204	32.050	0.164	0.017	2.47	101.5	1.14	-	5.6	0.0	95	261	81	72.7
205	32.207	0.157	0.017	2.45	101.5	1.17	-	5.6	0.0	95	260	81	72.5
206	32.367	0.160	0.018	2.45	101.5	1.17	-	5.5	0.0	95	261	81	72.5
207	32.530	0.163	0.018	2.45	101.7	1.16	-	5.5	0.0	95	259	81	72.6
208	32.685	0.155	0.018	2.44	101.7	1.15	-	5.5	0.0	95	258	81	72.7
209	32.849	0.164	0.017	2.43	101.7	1.17	-	5.5	0.0	95	257	81	72.7
210	33.005	0.156	0.017	2.43	101.8	1.15	101	5.4	0.0	95	256	81	72.8
211	33.166	0.161	0.017	2.44	101.8	1.15	-	5.4	0.0	94	254	81	72.8
212	33.328	0.162	0.017	2.45	101.8	1.16	-	5.4	0.0	94	252	81	72.8
213	33.484	0.156	0.018	2.45	101.8	1.17	-	5.3	0.0	94	254	81	72.7
214	33.647	0.163	0.018	2.43	101.9	1.17	-	5.3	0.0	94	256	81	72.6
215	33.804	0.157	0.017	2.45	101.9	1.16	-	5.2	0.0	95	256	81	72.6
216	33.964	0.160	0.017	2.44	101.9	1.16	-	5.2	-0.1	95	256	81	72.7
217	34.126	0.162	0.018	2.42	102	1.16	-	5.1	0.0	95	259	81	72.8
218	34.283	0.157	0.017	2.42	102	1.19	-	5.1	-0.1	95	260	81	72.7
219	34.446	0.163	0.017	2.43	102.1	1.18	-	5.0	0.0	95	262	81	72.7
220	34.603	0.157	0.018	2.45	102.1	1.15	100	5.0	0.0	95	266	81	72.7
221	34.763	0.160	0.017	2.43	102.1	1.14	-	4.9	-0.1	95	267	81	72.8
222	34.924	0.161	0.017	2.43	102.1	1.19	-	4.9	0.0	95	267	81	72.8
223	35.081	0.157	0.018	2.43	102.2	1.15	-	4.9	0.0	95	266	81	72.6
224	35.244	0.163	0.018	2.44	102.2	1.16	-	4.8	-0.1	96	267	81	72.7
225	35.402	0.158	0.017	2.45	102.2	1.13	-	4.8	0.0	96	269	81	72.7
226	35.562	0.160	0.017	2.44	102.3	1.18	-	4.8	0.0	96	267	81	72.9
227	35.723	0.161	0.018	2.45	102.3	1.19	-	4.7	-0.1	96	268	81	72.8
228	35.880	0.157	0.018	2.44	102.3	1.15	-	4.7	0.0	96	270	81	72.7
229	36.043	0.163	0.018	2.46	102.3	1.15	-	4.6	0.0	96	267	81	72.6
230	36.201	0.158	0.017	2.45	102.4	1.15	100	4.6	0.0	96	267	81	72.8

BOX A TEST DATA - ASTM E2779 / ASTM E2515

Client: Laminox
 Model: Phenix
 Run #: 1

Job #: 23-209
 Tracking #: 163
 Technician: AK
 Date: 10/16/2023

Elapsed Time (min)	Particulate Sampling Data							Fuel Weight (lb)		Temperature Data (°F)			
	Gas Meter (ft ³)	Sample Rate (cfm)	Dilution Tunnel dP (in H ₂ O)	Orifice dH (in H ₂ O)	Meter Temp (°F)	Meter Vacuum (in Hg)	Pro. Rate (%)	Scale Reading	Weight Change	Dilution Tunnel	Flue	Filter	Ambient
231	36.361	0.160	0.017	2.45	102.4	1.19	-	4.6	0.0	96	267	81	72.9
232	36.522	0.161	0.018	2.44	102.4	1.15	-	4.5	0.0	96	265	81	72.8
233	36.679	0.157	0.018	2.45	102.4	1.16	-	4.5	0.0	96	264	81	72.7
234	36.842	0.163	0.017	2.44	102.5	1.16	-	4.4	-0.1	96	264	81	72.9
235	37.000	0.158	0.017	2.44	102.5	1.17	-	4.4	0.0	96	265	81	72.9
236	37.160	0.160	0.017	2.44	102.5	1.16	-	4.4	0.0	96	263	81	72.9
237	37.321	0.161	0.017	2.43	102.6	1.14	-	4.3	0.0	96	263	81	72.9
238	37.478	0.157	0.017	2.43	102.6	1.14	-	4.3	0.0	96	261	81	73.2
239	37.640	0.162	0.017	2.45	102.7	1.19	-	4.2	-0.1	96	264	81	73.2
240	37.798	0.158	0.017	2.44	102.6	1.17	101	4.2	-0.1	96	267	81	73.5
241	37.959	0.161	0.018	2.44	102.6	1.16	-	4.2	0.0	96	267	81	73.3
242	38.120	0.161	0.017	2.45	102.7	1.16	-	4.1	0.0	96	264	81	73.4
243	38.277	0.157	0.017	2.45	102.8	1.13	-	4.1	0.0	96	265	82	73.4
244	38.439	0.162	0.017	2.45	102.8	1.17	-	4.0	-0.1	96	267	82	73.3
245	38.597	0.158	0.017	2.45	102.9	1.16	-	4.0	0.0	96	268	82	73.3
246	38.758	0.161	0.017	2.44	102.9	1.2	-	4.0	0.0	96	267	82	73.3
247	38.918	0.160	0.017	2.45	102.9	1.15	-	3.9	0.0	96	266	82	73.4
248	39.076	0.158	0.018	2.44	102.9	1.16	-	3.9	0.0	96	266	82	73.3
249	39.238	0.162	0.018	2.43	102.9	1.16	-	3.8	0.0	96	266	82	73.4
250	39.396	0.158	0.018	2.44	103	1.18	100	3.8	0.0	96	267	82	73.4
251	39.557	0.161	0.018	2.44	103	1.18	-	3.8	0.0	96	268	82	73.6
252	39.717	0.160	0.018	2.43	103.1	1.18	-	3.7	-0.1	96	267	82	73.6
253	39.875	0.158	0.017	2.44	103.1	1.15	-	3.7	0.0	96	266	82	73.7
254	40.037	0.162	0.018	2.44	103.1	1.18	-	3.6	0.0	96	266	82	73.6
255	40.195	0.158	0.018	2.43	103.1	1.16	-	3.6	0.0	96	265	82	73.5
256	40.356	0.161	0.018	2.43	103.2	1.16	-	3.6	0.0	96	266	82	73.6
257	40.516	0.160	0.018	2.41	103.2	1.17	-	3.5	0.0	96	267	82	73.7
258	40.674	0.158	0.018	2.41	103.2	1.17	-	3.5	0.0	96	267	82	73.7
259	40.836	0.162	0.017	2.40	103.2	1.15	-	3.4	-0.1	96	268	82	73.8
260	40.994	0.158	0.017	2.40	103.2	1.17	100	3.4	0.0	97	269	82	73.8
261	41.155	0.161	0.018	2.41	103.2	1.18	-	3.4	0.0	97	268	82	73.8
262	41.315	0.160	0.017	2.40	103.2	1.21	-	3.3	0.0	97	266	82	73.5
263	41.473	0.158	0.017	2.43	103.4	1.19	-	3.3	0.0	96	266	82	73.8

BOX A TEST DATA - ASTM E2779 / ASTM E2515

Client: Laminox
 Model: Phenix
 Run #: 1

Job #: 23-209
 Tracking #: 163
 Technician: AK
 Date: 10/16/2023

Elapsed Time (min)	Particulate Sampling Data							Fuel Weight (lb)		Temperature Data (°F)			
	Gas Meter (ft ³)	Sample Rate (cfm)	Dilution Tunnel dP (in H ₂ O)	Orifice dH (in H ₂ O)	Meter Temp (°F)	Meter Vacuum (in Hg)	Pro. Rate (%)	Scale Reading	Weight Change	Dilution Tunnel	Flue	Filter	Ambient
264	41.635	0.162	0.018	2.42	103.3	1.2	-	3.3	-0.1	96	265	82	73.8
265	41.793	0.158	0.017	2.42	103.3	1.18	-	3.2	0.0	97	266	82	73.6
266	41.954	0.161	0.017	2.43	103.4	1.2	-	3.2	0.0	97	267	82	73.7
267	42.114	0.160	0.017	2.43	103.5	1.19	-	3.1	0.0	97	266	82	73.7
268	42.272	0.158	0.018	2.44	103.5	1.2	-	3.1	0.0	97	265	82	73.8
269	42.434	0.162	0.017	2.42	103.5	1.19	-	3.1	0.0	97	265	82	73.9
270	42.592	0.158	0.017	2.45	103.6	1.2	101	3.0	0.0	96	264	82	73.7
271	42.752	0.160	0.017	2.46	103.5	1.17	-	3.0	0.0	96	263	82	73.9
272	42.913	0.161	0.018	2.45	103.6	1.18	-	3.0	0.0	96	263	82	74.1
273	43.071	0.158	0.017	2.45	103.6	1.19	-	2.9	0.0	96	264	82	74.2
274	43.232	0.161	0.017	2.43	103.6	1.17	-	2.9	0.0	96	262	82	74.1
275	43.390	0.158	0.017	2.43	103.7	1.18	-	2.8	0.0	96	262	82	73.9
276	43.551	0.161	0.017	2.44	103.7	1.16	-	2.8	0.0	96	262	82	74
277	43.711	0.160	0.017	2.45	103.7	1.21	-	2.8	0.0	96	259	82	73.8
278	43.870	0.159	0.018	2.43	103.8	1.18	-	2.8	0.0	96	257	82	74
279	44.031	0.161	0.017	2.42	103.8	1.18	-	2.7	0.0	96	255	82	74
280	44.189	0.158	0.017	2.39	103.8	1.2	101	2.7	-0.1	96	258	82	74
281	44.350	0.161	0.017	2.41	103.9	1.18	-	2.7	0.0	96	259	82	74.1
282	44.508	0.158	0.017	2.41	103.9	1.15	-	2.6	0.0	96	258	82	74
283	44.668	0.160	0.017	2.41	103.9	1.2	-	2.6	0.0	96	258	82	74.1
284	44.829	0.161	0.017	2.43	104	1.18	-	2.5	0.0	96	258	82	74.2
285	44.987	0.158	0.017	2.44	104	1.18	-	2.5	0.0	96	260	82	74.1
286	45.148	0.161	0.017	2.44	104	1.19	-	2.4	-0.1	96	263	82	74
287	45.306	0.158	0.017	2.42	104	1.18	-	2.4	0.0	96	262	82	74.1
288	45.467	0.161	0.018	2.42	103.9	1.19	-	2.4	0.0	96	261	82	74.2
289	45.628	0.161	0.017	2.43	104	1.18	-	2.4	0.0	96	259	82	74.3
290	45.785	0.157	0.017	2.41	104	1.17	101	2.3	0.0	96	258	82	74.4
291	45.947	0.162	0.017	2.43	104	1.2	-	2.3	0.0	96	257	82	74.4
292	46.104	0.157	0.018	2.42	104	1.18	-	2.3	0.0	95	256	82	74.2
293	46.265	0.161	0.018	2.42	103.9	1.18	-	2.2	0.0	95	257	82	74.1
294	46.425	0.160	0.018	2.41	103.9	1.21	-	2.2	-0.1	95	258	82	74.4
295	46.583	0.158	0.018	2.40	103.9	1.2	-	2.1	0.0	95	257	82	74.4
296	46.746	0.163	0.018	2.41	103.9	1.21	-	2.1	0.0	95	257	82	74.3

BOX A TEST DATA - ASTM E2779 / ASTM E2515

Client: Laminox
 Model: Phenix
 Run #: 1

Job #: 23-209
 Tracking #: 163
 Technician: AK
 Date: 10/16/2023

Elapsed Time (min)	Particulate Sampling Data							Fuel Weight (lb)		Temperature Data (°F)			
	Gas Meter (ft ³)	Sample Rate (cfm)	Dilution Tunnel dP (in H ₂ O)	Orifice dH (in H ₂ O)	Meter Temp (°F)	Meter Vacuum (in Hg)	Pro. Rate (%)	Scale Reading	Weight Change	Dilution Tunnel	Flue	Filter	Ambient
297	46.902	0.156	0.018	2.40	103.8	1.2	-	2.1	0.0	95	257	82	74.4
298	47.063	0.161	0.019	2.39	103.9	1.2	-	2.0	0.0	94	257	82	74.4
299	47.224	0.161	0.018	2.40	103.9	1.19	-	2.0	0.0	95	256	82	74.5
300	47.381	0.157	0.018	2.40	103.9	1.2	99	2.0	0.0	95	254	82	74.4
301	47.544	0.163	0.018	2.39	103.9	1.21	-	2.0	0.0	95	252	82	74.4
302	47.701	0.157	0.018	2.41	104	1.2	-	1.9	0.0	95	253	82	74.4
303	47.861	0.160	0.018	2.39	103.9	1.19	-	1.9	0.0	95	252	82	74.5
304	48.022	0.161	0.018	2.39	103.9	1.19	-	1.9	0.0	95	251	82	74.5
305	48.178	0.156	0.018	2.39	103.9	1.19	-	1.8	0.0	95	250	82	74.2
306	48.342	0.164	0.017	2.38	104	1.17	-	1.8	0.0	95	251	82	74.4
307	48.499	0.157	0.018	2.39	104	1.18	-	1.8	0.0	94	252	82	74.2
308	48.659	0.160	0.018	2.38	104	1.21	-	1.7	0.0	94	251	82	74.3
309	48.820	0.161	0.018	2.39	104	1.21	-	1.7	0.0	94	251	82	74.5
310	48.976	0.156	0.018	2.38	104	1.2	98	1.7	0.0	95	249	82	74.4
311	49.139	0.163	0.017	2.38	104.1	1.21	-	1.6	0.0	95	248	82	74
312	49.295	0.156	0.017	2.38	104	1.21	-	1.6	0.0	94	248	82	73.6
313	49.456	0.161	0.018	2.38	104	1.22	-	1.6	-0.1	93	250	81	73.8
314	49.617	0.161	0.018	2.37	104.1	1.22	-	1.5	0.0	94	250	81	73.9
315	49.773	0.156	0.018	2.38	103.9	1.23	-	1.5	0.0	94	249	81	73.8
316	49.936	0.163	0.018	2.37	103.9	1.21	-	1.5	0.0	93	248	81	74
317	50.092	0.156	0.018	2.38	103.9	1.21	-	1.4	-0.1	93	251	81	74.1
318	50.252	0.160	0.018	2.38	103.9	1.21	-	1.4	0.0	93	253	81	74.1
319	50.413	0.161	0.019	2.37	103.9	1.2	-	1.3	0.0	93	253	81	74.1
320	50.569	0.156	0.018	2.39	103.9	1.17	98	1.3	0.0	93	253	81	74.3
321	50.733	0.164	0.018	2.38	103.8	1.19	-	1.3	0.0	93	251	81	74.1
322	50.889	0.156	0.018	2.39	103.8	1.2	-	1.3	0.0	94	251	81	74.1
323	51.049	0.160	0.018	2.39	103.8	1.21	-	1.2	0.0	94	252	81	74.1
324	51.209	0.160	0.018	2.39	103.8	1.22	-	1.2	0.0	94	253	81	74.1
325	51.367	0.158	0.018	2.39	103.8	1.21	-	1.2	0.0	94	253	81	74.2
326	51.528	0.161	0.018	2.38	103.8	1.19	-	1.1	-0.1	94	254	81	74.1
327	51.685	0.157	0.018	2.38	103.8	1.2	-	1.1	0.0	94	254	81	74
328	51.845	0.160	0.018	2.39	103.8	1.19	-	1.0	0.0	94	254	81	74
329	52.004	0.159	0.018	2.39	103.8	1.21	-	1.0	0.0	94	253	81	74

BOX A TEST DATA - ASTM E2779 / ASTM E2515

Client: Laminox
 Model: Phenix
 Run #: 1

Job #: 23-209
 Tracking #: 163
 Technician: AK
 Date: 10/16/2023

Elapsed Time (min)	Particulate Sampling Data							Fuel Weight (lb)		Temperature Data (°F)			
	Gas Meter (ft ³)	Sample Rate (cfm)	Dilution Tunnel dP (in H ₂ O)	Orifice dH (in H ₂ O)	Meter Temp (°F)	Meter Vacuum (in Hg)	Pro. Rate (%)	Scale Reading	Weight Change	Dilution Tunnel	Flue	Filter	Ambient
330	52.163	0.159	0.018	2.39	103.7	1.23	98	1.0	0.0	94	254	81	74.1
331	52.323	0.160	0.018	2.40	103.7	1.19	-	0.9	0.0	94	253	81	73.9
332	52.480	0.157	0.018	2.39	103.7	1.21	-	0.9	0.0	94	251	81	74.2
333	52.642	0.162	0.018	2.39	103.7	1.21	-	0.9	0.0	94	249	81	74.3
334	52.798	0.156	0.018	2.40	103.7	1.21	-	0.9	0.0	94	248	81	74.3
335	52.959	0.161	0.018	2.39	103.7	1.2	-	0.8	0.0	94	246	81	74.3
336	53.119	0.160	0.018	2.40	103.7	1.21	-	0.8	0.0	93	245	81	74.2
337	53.274	0.155	0.018	2.38	103.7	1.21	-	0.8	0.0	93	245	81	74.1
338	53.437	0.163	0.018	2.39	103.7	1.23	-	0.8	0.0	93	243	81	74.1
339	53.593	0.156	0.018	2.40	103.8	1.19	-	0.7	0.0	93	242	81	74.3
340	53.754	0.161	0.018	2.39	103.7	1.22	97	0.7	0.0	93	242	81	74.3
341	53.915	0.161	0.018	2.40	103.7	1.2	-	0.7	0.0	93	243	81	74.3
342	54.070	0.155	0.018	2.40	103.7	1.2	-	0.6	0.0	93	240	81	74.5
343	54.233	0.163	0.018	2.39	103.7	1.19	-	0.6	0.0	93	239	81	74.3
344	54.389	0.156	0.018	2.39	103.7	1.22	-	0.6	0.0	93	243	81	74.4
345	54.548	0.159	0.019	2.38	103.7	1.21	-	0.5	-0.1	93	247	81	74.4
346	54.709	0.161	0.019	2.39	103.7	1.2	-	0.5	0.0	92	249	81	74.5
347	54.865	0.156	0.018	2.39	103.6	1.22	-	0.4	-0.1	93	249	81	74.5
348	55.026	0.161	0.018	2.39	103.7	1.2	-	0.4	0.0	93	253	81	74.3
349	55.183	0.157	0.018	2.38	103.7	1.2	-	0.4	0.0	93	251	81	74.4
350	55.343	0.160	0.019	2.40	103.7	1.23	96	0.3	0.0	93	249	81	74.2
351	55.501	0.158	0.018	2.41	103.6	1.21	-	0.3	0.0	93	246	81	74.1
352	55.660	0.159	0.018	2.41	103.6	1.22	-	0.3	0.0	93	245	81	74.2
353	55.821	0.161	0.018	2.41	103.6	1.22	-	0.2	0.0	93	248	81	74.2
354	55.977	0.156	0.019	2.41	103.6	1.22	-	0.2	0.0	93	248	81	74.2
355	56.139	0.162	0.018	2.41	103.6	1.23	-	0.2	0.0	93	249	81	74.2
356	56.294	0.155	0.018	2.40	103.5	1.21	-	0.2	0.0	93	248	81	74.2
357	56.454	0.160	0.018	2.40	103.6	1.22	-	0.1	0.0	93	247	81	74.2
358	56.615	0.161	0.018	2.39	103.6	1.22	-	0.1	0.0	93	250	81	74.2
359	56.769	0.154	0.019	2.38	103.6	1.22	-	0.0	0.0	93	250	81	74.2
360	56.932	0.163	0.018	2.39	103.6	1.2	96	0.0	0.0	93	250	81	74
Avg/Tot	56.932	0.158	0.017	2.43	97	1.11	100			97	293	80	72

BOX B TEST DATA - ASTM E2779 / ASTM E2515

Client: LaminoxJob #: 23-209Model: PhenixTracking #: 163Run #: 1Technician: AKDate: 10/16/2023

Elapsed Time (min)	Particulate Sampling Data							Flue Gas Data		
	Gas Meter (ft ³)	Sample Rate (cfm)	Orifice dH (in H ₂ O)	Meter Temp (°F)	Meter Vacuum (in Hg)	Pro. Rate (%)	Filter (°F)	Flue Draft (in H ₂ O)	CO ₂ (%)	CO (%)
0	0.000		1.64	72	1.45		72	-0.055	13.24	0.03
1	0.111	0.111	2.43	71.9	1.91	-	74	-0.055	12.15	0.02
2	0.260	0.149	2.43	72	1.96	-	75	-0.055	14.02	0.09
3	0.413	0.153	2.43	72	1.86	-	76	-0.056	12.22	0.03
4	0.563	0.150	2.44	72.1	2.03	-	76	-0.055	11.39	0.03
5	0.717	0.154	2.44	72.2	1.47	-	76	-0.055	8.97	0.02
6	0.866	0.149	2.43	72.3	1.67	-	77	-0.054	14.80	0.09
7	1.021	0.155	2.44	72.3	2.03	-	77	-0.056	13.91	0.04
8	1.170	0.149	2.45	72.5	1.74	-	77	-0.056	14.19	0.11
9	1.323	0.153	2.44	72.7	1.94	-	78	-0.055	12.92	0.02
10	1.474	0.151	2.44	72.8	1.9	100	78	-0.055	14.66	0.11
11	1.627	0.153	2.43	73.1	1.74	-	78	-0.054	11.20	0.02
12	1.779	0.152	2.45	73.3	1.49	-	78	-0.055	10.88	0.02
13	1.932	0.153	2.45	73.5	1.5	-	78	-0.056	12.86	0.03
14	2.084	0.152	2.44	73.8	1.8	-	79	-0.055	11.42	0.02
15	2.236	0.152	2.45	74	2	-	79	-0.056	9.67	0.02
16	2.389	0.153	2.44	74.3	1.7	-	79	-0.056	14.61	0.05
17	2.540	0.151	2.44	74.6	1.55	-	79	-0.054	12.91	0.02
18	2.693	0.153	2.43	74.9	2.01	-	79	-0.055	12.76	0.03
19	2.844	0.151	2.44	75.2	1.56	-	80	-0.055	13.54	0.06
20	2.999	0.155	2.45	75.5	1.62	104	80	-0.054	12.35	0.02
21	3.150	0.151	2.44	75.8	2	-	80	-0.056	10.39	0.02
22	3.304	0.154	2.45	76.2	2.02	-	80	-0.055	12.77	0.02
23	3.455	0.151	2.44	76.5	1.54	-	80	-0.055	13.03	0.02
24	3.609	0.154	2.43	76.8	1.69	-	80	-0.054	14.49	0.10
25	3.760	0.151	2.44	77.2	1.78	-	80	-0.055	14.04	0.04
26	3.915	0.155	2.44	77.5	1.68	-	81	-0.055	11.11	0.02
27	4.068	0.153	2.44	77.9	1.85	-	81	-0.056	9.13	0.02
28	4.220	0.152	2.45	78.2	1.99	-	81	-0.054	15.01	0.16
29	4.374	0.154	2.44	78.6	2.03	-	81	-0.056	12.81	0.02
30	4.524	0.150	2.43	78.9	1.58	102	81	-0.054	12.71	0.02
31	4.680	0.156	2.44	79.3	1.98	-	81	-0.056	13.24	0.03

BOX B TEST DATA - ASTM E2779 / ASTM E2515

Client: Laminox
 Model: Phenix
 Run #: 1

Job #: 23-209
 Tracking #: 163
 Technician: AK
 Date: 10/16/2023

Elapsed Time (min)	Particulate Sampling Data							Flue Gas Data		
	Gas Meter (ft ³)	Sample Rate (cfm)	Orifice dH (in H ₂ O)	Meter Temp (°F)	Meter Vacuum (in Hg)	Pro. Rate (%)	Filter (°F)	Flue Draft (in H ₂ O)	CO ₂ (%)	CO (%)
32	4.831	0.151	2.44	79.5	1.87	-	81	-0.053	15.58	0.37
33	4.986	0.155	2.44	79.8	1.59	-	81	-0.054	10.87	0.02
34	5.137	0.151	2.44	80.1	1.86	-	81	-0.054	11.82	0.02
35	5.291	0.154	2.43	80.6	1.98	-	81	-0.055	12.86	0.03
36	5.443	0.152	2.42	80.9	1.86	-	82	-0.055	12.39	0.03
37	5.597	0.154	2.43	81.2	1.98	-	82	-0.056	12.86	0.02
38	5.751	0.154	2.43	81.6	1.79	-	82	-0.054	13.91	0.03
39	5.904	0.153	2.44	81.9	1.75	-	82	-0.054	13.63	0.04
40	6.057	0.153	2.43	82.2	1.9	101	82	-0.054	10.79	0.02
41	6.209	0.152	2.43	82.5	1.69	-	82	-0.053	12.13	0.02
42	6.365	0.156	2.43	82.9	1.87	-	82	-0.056	14.01	0.05
43	6.516	0.151	2.43	83.2	1.63	-	82	-0.054	13.77	0.05
44	6.672	0.156	2.43	83.5	1.76	-	82	-0.055	13.14	0.02
45	6.823	0.151	2.43	83.9	1.74	-	82	-0.054	13.93	0.05
46	6.978	0.155	2.42	84.1	1.6	-	82	-0.055	12.52	0.02
47	7.130	0.152	2.42	84.4	1.94	-	82	-0.055	11.91	0.01
48	7.285	0.155	2.43	84.8	1.6	-	82	-0.055	13.51	0.03
49	7.440	0.155	2.43	85	2.03	-	82	-0.055	10.07	0.01
50	7.592	0.152	2.42	85.3	1.69	102	82	-0.054	11.01	0.02
51	7.747	0.155	2.42	85.6	1.65	-	82	-0.055	11.31	0.01
52	7.899	0.152	2.43	85.8	1.94	-	82	-0.055	15.33	0.11
53	8.056	0.157	2.42	86.1	1.75	-	82	-0.056	12.85	0.02
54	8.208	0.152	2.43	86.4	1.87	-	83	-0.055	12.89	0.02
55	8.363	0.155	2.42	86.6	1.66	-	83	-0.055	14.30	0.06
56	8.515	0.152	2.41	86.9	1.7	-	83	-0.057	13.38	0.03
57	8.671	0.156	2.42	87.1	1.99	-	83	-0.053	11.45	0.02
58	8.825	0.154	2.41	87.4	1.73	-	83	-0.056	13.36	0.02
59	8.978	0.153	2.42	87.7	1.76	-	83	-0.057	11.96	0.02
60	9.134	0.156	2.42	87.9	2.05	103	83	-0.054	12.60	0.01
61	9.285	0.151	2.41	88.1	2.06	-	83	-0.054	10.33	0.02
62	9.442	0.157	2.42	88.4	2.07	-	83	-0.054	8.27	0.01
63	9.594	0.152	2.43	88.6	2.07	-	83	-0.054	10.50	0.01

BOX B TEST DATA - ASTM E2779 / ASTM E2515

Client: Laminox
 Model: Phenix
 Run #: 1

Job #: 23-209
 Tracking #: 163
 Technician: AK
 Date: 10/16/2023

Elapsed Time (min)	Particulate Sampling Data							Flue Gas Data		
	Gas Meter (ft ³)	Sample Rate (cfm)	Orifice dH (in H ₂ O)	Meter Temp (°F)	Meter Vacuum (in Hg)	Pro. Rate (%)	Filter (°F)	Flue Draft (in H ₂ O)	CO ₂ (%)	CO (%)
64	9.750	0.156	2.42	88.8	1.99	-	83	-0.054	11.09	0.02
65	9.902	0.152	2.42	89	2.1	-	83	-0.052	9.12	0.01
66	10.058	0.156	2.42	89.3	2.09	-	83	-0.052	9.35	0.01
67	10.213	0.155	2.41	89.5	2.04	-	83	-0.053	9.89	0.02
68	10.367	0.154	2.43	89.7	1.58	-	83	-0.052	8.54	0.02
69	10.523	0.156	2.42	89.9	1.59	-	83	-0.052	7.37	0.01
70	10.675	0.152	2.42	90.1	1.7	103	83	-0.049	9.12	0.01
71	10.832	0.157	2.42	90.2	1.64	-	83	-0.053	9.95	0.01
72	10.985	0.153	2.43	90.5	1.73	-	83	-0.048	8.23	0.02
73	11.141	0.156	2.42	90.7	1.95	-	82	-0.050	8.30	0.02
74	11.293	0.152	2.42	90.9	1.88	-	82	-0.049	7.38	0.02
75	11.450	0.157	2.42	91.1	1.79	-	82	-0.049	8.30	0.02
76	11.606	0.156	2.43	91.3	1.61	-	82	-0.050	8.72	0.01
77	11.758	0.152	2.42	91.4	1.96	-	82	-0.049	9.03	0.01
78	11.915	0.157	2.42	91.6	1.59	-	82	-0.049	7.20	0.02
79	12.068	0.153	2.42	91.7	1.59	-	82	-0.046	8.68	0.02
80	12.226	0.158	2.43	91.9	1.77	103	82	-0.048	6.54	0.03
81	12.378	0.152	2.42	92.1	1.95	-	82	-0.051	6.19	0.03
82	12.534	0.156	2.42	92.2	2.05	-	82	-0.049	10.54	0.01
83	12.690	0.156	2.43	92.4	1.9	-	82	-0.048	9.47	0.02
84	12.844	0.154	2.42	92.5	2.09	-	82	-0.049	7.33	0.03
85	13.000	0.156	2.42	92.6	2.1	-	82	-0.047	7.42	0.02
86	13.153	0.153	2.42	92.9	2.07	-	82	-0.047	6.60	0.03
87	13.311	0.158	2.42	93	1.63	-	82	-0.045	6.95	0.03
88	13.464	0.153	2.42	93.2	1.63	-	82	-0.047	9.26	0.02
89	13.620	0.156	2.42	93.2	1.59	-	82	-0.048	7.65	0.02
90	13.774	0.154	2.42	93.3	1.79	102	82	-0.046	7.76	0.02
91	13.930	0.156	2.42	93.5	1.85	-	82	-0.047	6.99	0.03
92	14.086	0.156	2.42	93.6	1.8	-	82	-0.047	6.40	0.03
93	14.239	0.153	2.41	93.8	2.09	-	82	-0.044	6.34	0.04
94	14.397	0.158	2.42	93.9	2.1	-	82	-0.046	8.44	0.01
95	14.550	0.153	2.41	94	1.63	-	82	-0.045	7.11	0.03

BOX B TEST DATA - ASTM E2779 / ASTM E2515

Client: Laminox
 Model: Phenix
 Run #: 1

Job #: 23-209
 Tracking #: 163
 Technician: AK
 Date: 10/16/2023

Elapsed Time (min)	Particulate Sampling Data							Flue Gas Data		
	Gas Meter (ft ³)	Sample Rate (cfm)	Orifice dH (in H ₂ O)	Meter Temp (°F)	Meter Vacuum (in Hg)	Pro. Rate (%)	Filter (°F)	Flue Draft (in H ₂ O)	CO ₂ (%)	CO (%)
96	14.707	0.157	2.42	94.1	1.61	-	82	-0.045	7.11	0.03
97	14.860	0.153	2.41	94.2	1.76	-	82	-0.045	6.45	0.03
98	15.017	0.157	2.42	94.3	2.05	-	82	-0.043	5.25	0.06
99	15.174	0.157	2.42	94.4	1.77	-	82	-0.045	9.95	0.01
100	15.326	0.152	2.41	94.6	1.97	102	82	-0.047	8.32	0.02
101	15.483	0.157	2.41	94.7	2.06	-	81	-0.043	5.93	0.04
102	15.637	0.154	2.41	94.7	1.6	-	81	-0.043	5.92	0.04
103	15.795	0.158	2.42	94.8	1.67	-	81	-0.046	8.66	0.01
104	15.948	0.153	2.42	94.9	2.06	-	81	-0.044	6.48	0.04
105	16.104	0.156	2.42	95	1.84	-	81	-0.045	6.27	0.04
106	16.260	0.156	2.41	95.1	1.7	-	81	-0.043	7.30	0.03
107	16.415	0.155	2.42	95.2	1.66	-	81	-0.044	6.95	0.03
108	16.571	0.156	2.42	95.3	2.01	-	81	-0.042	6.44	0.03
109	16.725	0.154	2.41	95.3	1.63	-	81	-0.045	5.80	0.05
110	16.883	0.158	2.41	95.4	1.65	102	81	-0.045	7.26	0.03
111	17.035	0.152	2.41	95.5	1.68	-	81	-0.041	5.72	0.04
112	17.192	0.157	2.40	95.6	1.93	-	81	-0.044	5.13	0.04
113	17.348	0.156	2.41	95.7	1.7	-	81	-0.042	4.96	0.04
114	17.504	0.156	2.41	95.7	2.03	-	81	-0.042	9.81	0.01
115	17.660	0.156	2.41	95.7	1.69	-	81	-0.044	10.01	0.02
116	17.812	0.152	2.41	95.9	1.66	-	81	-0.044	7.31	0.04
117	17.971	0.159	2.41	96	2.02	-	81	-0.043	6.65	0.04
118	18.124	0.153	2.41	96.1	1.67	-	81	-0.042	6.29	0.05
119	18.280	0.156	2.41	96.1	2.03	-	81	-0.043	7.54	0.02
120	18.435	0.155	2.40	96.2	1.66	102	81	-0.046	8.16	0.02
121	18.591	0.156	2.41	96.3	1.84	-	81	-0.042	6.46	0.04
122	18.747	0.156	2.41	96.3	1.67	-	81	-0.042	7.32	0.04
123	18.900	0.153	2.40	96.3	2.1	-	81	-0.041	5.90	0.05
124	19.059	0.159	2.41	96.4	1.84	-	81	-0.043	7.56	0.02
125	19.213	0.154	2.41	96.6	2.06	-	81	-0.044	7.77	0.02
126	19.370	0.157	2.41	96.6	1.68	-	81	-0.044	7.42	0.02
127	19.524	0.154	2.41	96.6	2.13	-	81	-0.046	8.64	0.02

BOX B TEST DATA - ASTM E2779 / ASTM E2515

Client: Laminox
 Model: Phenix
 Run #: 1

Job #: 23-209
 Tracking #: 163
 Technician: AK
 Date: 10/16/2023

Elapsed Time (min)	Particulate Sampling Data							Flue Gas Data		
	Gas Meter (ft ³)	Sample Rate (cfm)	Orifice dH (in H ₂ O)	Meter Temp (°F)	Meter Vacuum (in Hg)	Pro. Rate (%)	Filter (°F)	Flue Draft (in H ₂ O)	CO ₂ (%)	CO (%)
128	19.680	0.156	2.40	96.6	1.58	-	81	-0.043	7.84	0.02
129	19.836	0.156	2.41	96.7	2.06	-	81	-0.043	6.18	0.03
130	19.990	0.154	2.40	96.8	1.99	102	81	-0.045	6.82	0.03
131	20.148	0.158	2.41	96.8	1.89	-	81	-0.041	8.19	0.01
132	20.301	0.153	2.41	96.8	1.89	-	81	-0.043	6.37	0.04
133	20.458	0.157	2.40	97	1.65	-	81	-0.045	5.92	0.04
134	20.612	0.154	2.40	97	1.6	-	81	-0.043	8.98	0.02
135	20.769	0.157	2.40	97.1	1.94	-	81	-0.045	7.67	0.02
136	20.925	0.156	2.41	97.2	1.64	-	81	-0.041	7.25	0.02
137	21.079	0.154	2.41	97.2	2.14	-	81	-0.043	6.85	0.04
138	21.236	0.157	2.41	97.3	1.84	-	81	-0.043	5.99	0.03
139	21.389	0.153	2.40	97.4	1.85	-	81	-0.043	5.66	0.03
140	21.547	0.158	2.41	97.4	2.14	102	81	-0.043	7.40	0.03
141	21.700	0.153	2.40	97.4	1.62	-	81	-0.044	6.24	0.03
142	21.857	0.157	2.40	97.5	1.61	-	81	-0.045	7.01	0.03
143	22.013	0.156	2.39	97.5	1.66	-	81	-0.045	9.39	0.01
144	22.166	0.153	2.39	97.6	2.12	-	81	-0.045	8.85	0.02
145	22.323	0.157	2.39	97.6	1.69	-	81	-0.042	6.80	0.02
146	22.477	0.154	2.39	97.6	1.6	-	81	-0.044	7.07	0.02
147	22.635	0.158	2.39	97.8	1.75	-	81	-0.044	8.66	0.01
148	22.787	0.152	2.40	97.7	1.61	-	81	-0.044	8.58	0.01
149	22.944	0.157	2.39	97.8	1.77	-	81	-0.043	7.89	0.02
150	23.099	0.155	2.39	97.8	1.82	101	81	-0.045	7.00	0.02
151	23.254	0.155	2.40	97.9	1.94	-	81	-0.043	6.40	0.03
152	23.411	0.157	2.39	98	2.03	-	81	-0.045	6.74	0.04
153	23.564	0.153	2.39	98	1.61	-	81	-0.041	5.01	0.04
154	23.721	0.157	2.38	98	1.65	-	81	-0.043	6.83	0.03
155	23.874	0.153	2.40	97.9	1.61	-	81	-0.043	5.50	0.03
156	24.031	0.157	2.39	98.1	2	-	81	-0.043	5.86	0.03
157	24.186	0.155	2.39	98	1.78	-	81	-0.043	6.76	0.03
158	24.341	0.155	2.39	98.1	1.75	-	81	-0.045	8.97	0.01
159	24.497	0.156	2.39	98.2	2.1	-	81	-0.043	8.53	0.01

BOX B TEST DATA - ASTM E2779 / ASTM E2515

Client: Laminox
 Model: Phenix
 Run #: 1

Job #: 23-209
 Tracking #: 163
 Technician: AK
 Date: 10/16/2023

Elapsed Time (min)	Particulate Sampling Data							Flue Gas Data		
	Gas Meter (ft ³)	Sample Rate (cfm)	Orifice dH (in H ₂ O)	Meter Temp (°F)	Meter Vacuum (in Hg)	Pro. Rate (%)	Filter (°F)	Flue Draft (in H ₂ O)	CO ₂ (%)	CO (%)
160	24.650	0.153	2.38	98.2	1.95	101	81	-0.045	6.54	0.02
161	24.808	0.158	2.39	98.3	1.97	-	82	-0.043	6.63	0.02
162	24.962	0.154	2.39	98.4	1.77	-	82	-0.041	5.22	0.04
163	25.118	0.156	2.39	98.4	2.05	-	82	-0.044	8.44	0.01
164	25.271	0.153	2.38	98.5	2.14	-	82	-0.043	7.11	0.03
165	25.428	0.157	2.39	98.6	1.62	-	82	-0.044	5.10	0.04
166	25.584	0.156	2.39	98.6	1.62	-	82	-0.043	9.73	0.01
167	25.737	0.153	2.39	98.5	1.75	-	82	-0.043	9.52	0.01
168	25.894	0.157	2.38	98.6	1.9	-	82	-0.045	7.67	0.01
169	26.048	0.154	2.39	98.7	1.66	-	82	-0.044	8.86	0.01
170	26.205	0.157	2.39	98.7	2.05	101	82	-0.042	6.39	0.02
171	26.358	0.153	2.38	98.8	2.04	-	82	-0.045	9.33	0.02
172	26.514	0.156	2.39	98.8	2.05	-	82	-0.046	7.57	0.02
173	26.670	0.156	2.38	98.9	1.97	-	82	-0.044	6.87	0.02
174	26.824	0.154	2.39	98.9	1.69	-	82	-0.045	7.81	0.01
175	26.980	0.156	2.38	98.9	1.84	-	82	-0.046	7.14	0.02
176	27.134	0.154	2.37	99	1.62	-	82	-0.045	6.26	0.02
177	27.291	0.157	2.38	99	1.64	-	82	-0.044	7.61	0.01
178	27.444	0.153	2.38	99.1	2.04	-	82	-0.046	9.21	0.01
179	27.600	0.156	2.38	99	2.14	-	82	-0.044	8.36	0.01
180	27.755	0.155	2.38	99	2	101	82	-0.046	7.10	0.02
181	27.910	0.155	2.38	99.1	1.62	-	82	-0.044	5.81	0.02
182	28.066	0.156	2.38	99.1	2.07	-	82	-0.043	5.30	0.04
183	28.219	0.153	2.38	99.1	1.67	-	82	-0.044	6.62	0.03
184	28.377	0.158	2.38	99	1.77	-	82	-0.047	6.52	0.02
185	28.530	0.153	2.38	99.1	1.99	-	82	-0.044	6.88	0.02
186	28.686	0.156	2.38	99.2	1.76	-	82	-0.041	5.74	0.03
187	28.839	0.153	2.37	99.3	1.87	-	82	-0.042	5.29	0.03
188	28.996	0.157	2.38	99.2	1.67	-	82	-0.043	5.50	0.06
189	29.152	0.156	2.38	99.3	1.67	-	82	-0.042	6.07	0.05
190	29.305	0.153	2.38	99.4	1.69	99	82	-0.042	6.89	0.02
191	29.461	0.156	2.37	99.4	1.81	-	82	-0.044	5.69	0.03

BOX B TEST DATA - ASTM E2779 / ASTM E2515

Client: Laminox
 Model: Phenix
 Run #: 1

Job #: 23-209
 Tracking #: 163
 Technician: AK
 Date: 10/16/2023

Elapsed Time (min)	Particulate Sampling Data							Flue Gas Data		
	Gas Meter (ft ³)	Sample Rate (cfm)	Orifice dH (in H ₂ O)	Meter Temp (°F)	Meter Vacuum (in Hg)	Pro. Rate (%)	Filter (°F)	Flue Draft (in H ₂ O)	CO ₂ (%)	CO (%)
192	29.615	0.154	2.37	99.5	1.66	-	82	-0.039	5.16	0.03
193	29.773	0.158	2.37	99.4	1.73	-	82	-0.040	6.07	0.04
194	29.925	0.152	2.37	99.4	1.87	-	82	-0.041	6.54	0.04
195	30.081	0.156	2.37	99.5	1.63	-	82	-0.040	5.98	0.03
196	30.236	0.155	2.37	99.4	1.61	-	82	-0.040	5.63	0.04
197	30.391	0.155	2.37	99.4	2.1	-	82	-0.043	6.93	0.03
198	30.546	0.155	2.38	99.3	1.81	-	82	-0.040	5.00	0.04
199	30.699	0.153	2.37	99.5	1.99	-	82	-0.039	5.38	0.05
200	30.857	0.158	2.36	99.6	1.63	99	82	-0.040	5.85	0.04
201	31.010	0.153	2.37	99.5	2.12	-	82	-0.039	5.90	0.05
202	31.166	0.156	2.37	99.6	1.62	-	82	-0.041	5.72	0.03
203	31.319	0.153	2.36	99.7	1.64	-	82	-0.039	4.75	0.03
204	31.475	0.156	2.36	99.8	1.71	-	82	-0.040	4.28	0.04
205	31.631	0.156	2.37	99.6	2.16	-	82	-0.040	5.60	0.03
206	31.784	0.153	2.37	99.6	1.89	-	82	-0.040	6.39	0.03
207	31.940	0.156	2.37	99.7	2.04	-	82	-0.041	5.53	0.04
208	32.094	0.154	2.36	99.7	1.73	-	82	-0.038	4.31	0.03
209	32.251	0.157	2.37	99.8	1.61	-	82	-0.039	4.88	0.02
210	32.403	0.152	2.37	100	1.76	100	82	-0.039	6.17	0.08
211	32.559	0.156	2.36	99.9	1.69	-	82	-0.039	4.66	0.02
212	32.714	0.155	2.36	99.8	2.05	-	82	-0.040	4.55	0.03
213	32.869	0.155	2.37	99.8	2.08	-	82	-0.039	6.99	0.02
214	33.024	0.155	2.36	99.8	1.71	-	82	-0.040	6.70	0.02
215	33.177	0.153	2.36	99.9	1.81	-	82	-0.041	6.02	0.02
216	33.334	0.157	2.36	100	1.75	-	82	-0.042	6.88	0.01
217	33.487	0.153	2.37	100.1	1.99	-	82	-0.036	7.16	0.02
218	33.643	0.156	2.36	100	1.85	-	82	-0.041	7.79	0.02
219	33.796	0.153	2.36	100	1.84	-	82	-0.042	7.75	0.01
220	33.952	0.156	2.36	99.9	1.68	99	82	-0.040	7.45	0.02
221	34.107	0.155	2.36	100	1.77	-	82	-0.042	8.33	0.01
222	34.260	0.153	2.35	100.1	1.74	-	83	-0.040	5.87	0.04
223	34.416	0.156	2.35	100	2.06	-	83	-0.043	5.02	0.04

BOX B TEST DATA - ASTM E2779 / ASTM E2515

Client: Laminox
 Model: Phenix
 Run #: 1

Job #: 23-209
 Tracking #: 163
 Technician: AK
 Date: 10/16/2023

Elapsed Time (min)	Particulate Sampling Data							Flue Gas Data		
	Gas Meter (ft ³)	Sample Rate (cfm)	Orifice dH (in H ₂ O)	Meter Temp (°F)	Meter Vacuum (in Hg)	Pro. Rate (%)	Filter (°F)	Flue Draft (in H ₂ O)	CO ₂ (%)	CO (%)
224	34.569	0.153	2.35	100.1	1.68	-	83	-0.040	8.23	0.01
225	34.726	0.157	2.36	100.1	1.9	-	83	-0.040	6.65	0.05
226	34.878	0.152	2.36	100.2	2.11	-	83	-0.040	6.27	0.03
227	35.034	0.156	2.36	100.2	2.01	-	83	-0.040	5.51	0.06
228	35.188	0.154	2.36	100.2	1.64	-	83	-0.041	8.24	0.02
229	35.343	0.155	2.35	100.2	2.09	-	83	-0.042	6.06	0.04
230	35.499	0.156	2.36	100.4	1.68	99	83	-0.042	5.89	0.03
231	35.651	0.152	2.36	100.5	1.63	-	83	-0.039	5.60	0.03
232	35.808	0.157	2.36	100.4	1.68	-	83	-0.041	5.46	0.03
233	35.961	0.153	2.35	100.5	1.88	-	83	-0.041	6.52	0.04
234	36.118	0.157	2.36	100.5	1.93	-	83	-0.040	7.42	0.02
235	36.269	0.151	2.36	100.5	1.67	-	83	-0.042	5.37	0.03
236	36.425	0.156	2.35	100.5	1.62	-	83	-0.042	5.32	0.04
237	36.580	0.155	2.35	100.6	1.81	-	83	-0.041	5.63	0.04
238	36.735	0.155	2.36	100.7	2.18	-	83	-0.039	5.01	0.04
239	36.890	0.155	2.35	100.8	1.74	-	83	-0.041	8.44	0.00
240	37.042	0.152	2.35	100.9	1.94	100	83	-0.038	8.87	0.00
241	37.200	0.158	2.36	100.8	1.79	-	83	-0.043	5.98	0.03
242	37.352	0.152	2.35	100.8	1.82	-	83	-0.041	4.59	0.03
243	37.508	0.156	2.35	100.7	2.04	-	83	-0.041	7.71	0.01
244	37.661	0.153	2.35	100.8	1.67	-	83	-0.041	6.97	0.02
245	37.817	0.156	2.35	100.8	2.16	-	83	-0.042	6.08	0.02
246	37.972	0.155	2.35	100.8	1.68	-	83	-0.040	6.63	0.02
247	38.126	0.154	2.36	100.9	1.78	-	83	-0.039	5.86	0.03
248	38.281	0.155	2.35	100.9	1.66	-	83	-0.042	5.78	0.03
249	38.434	0.153	2.36	100.9	1.67	-	83	-0.042	7.13	0.02
250	38.591	0.157	2.35	100.9	1.62	99	83	-0.040	6.76	0.01
251	38.744	0.153	2.36	101.1	1.73	-	83	-0.041	6.38	0.02
252	38.900	0.156	2.35	101	1.75	-	83	-0.040	7.24	0.01
253	39.052	0.152	2.35	101	1.96	-	83	-0.044	6.33	0.02
254	39.209	0.157	2.34	100.9	2.14	-	83	-0.040	6.21	0.01
255	39.364	0.155	2.35	101	1.92	-	83	-0.040	5.67	0.03

BOX B TEST DATA - ASTM E2779 / ASTM E2515

Client: Laminox
 Model: Phenix
 Run #: 1

Job #: 23-209
 Tracking #: 163
 Technician: AK
 Date: 10/16/2023

Elapsed Time (min)	Particulate Sampling Data							Flue Gas Data		
	Gas Meter (ft ³)	Sample Rate (cfm)	Orifice dH (in H ₂ O)	Meter Temp (°F)	Meter Vacuum (in Hg)	Pro. Rate (%)	Filter (°F)	Flue Draft (in H ₂ O)	CO ₂ (%)	CO (%)
256	39.517	0.153	2.36	101	1.64	-	84	-0.041	6.89	0.02
257	39.673	0.156	2.34	101.1	1.68	-	84	-0.040	6.31	0.02
258	39.826	0.153	2.35	101.1	1.78	-	84	-0.040	6.39	0.02
259	39.983	0.157	2.35	101.1	1.62	-	84	-0.039	5.84	0.04
260	40.134	0.151	2.34	101.2	1.68	99	84	-0.039	7.05	0.02
261	40.290	0.156	2.34	101.1	2.1	-	84	-0.040	6.11	0.03
262	40.445	0.155	2.34	101.1	1.65	-	83	-0.042	6.15	0.04
263	40.600	0.155	2.34	101.1	1.95	-	84	-0.041	5.84	0.03
264	40.755	0.155	2.35	101.2	2.06	-	83	-0.040	5.82	0.02
265	40.908	0.153	2.34	101.2	2.16	-	84	-0.041	7.43	0.01
266	41.065	0.157	2.35	101.3	1.72	-	84	-0.041	6.30	0.01
267	41.217	0.152	2.34	101.3	1.77	-	84	-0.043	6.67	0.02
268	41.374	0.157	2.35	101.3	1.65	-	84	-0.040	5.24	0.03
269	41.526	0.152	2.34	101.3	2.16	-	84	-0.040	4.50	0.03
270	41.681	0.155	2.35	101.3	2.16	100	84	-0.039	6.58	0.01
271	41.836	0.155	2.34	101.4	2.11	-	84	-0.040	5.14	0.03
272	41.991	0.155	2.34	101.5	2.03	-	84	-0.040	6.93	0.02
273	42.146	0.155	2.35	101.5	1.8	-	84	-0.042	6.45	0.01
274	42.298	0.152	2.33	101.4	1.68	-	84	-0.041	5.68	0.02
275	42.455	0.157	2.34	101.4	1.72	-	84	-0.038	5.84	0.02
276	42.607	0.152	2.34	101.4	1.79	-	84	-0.040	5.91	0.03
277	42.763	0.156	2.34	101.4	1.74	-	84	-0.040	4.50	0.03
278	42.916	0.153	2.34	101.5	1.94	-	84	-0.039	4.44	0.01
279	43.072	0.156	2.34	101.5	1.76	-	84	-0.038	4.09	0.02
280	43.226	0.154	2.33	101.5	1.67	100	84	-0.041	7.07	0.01
281	43.380	0.154	2.34	101.6	1.65	-	84	-0.038	7.03	0.02
282	43.535	0.155	2.34	101.7	2.18	-	84	-0.039	6.12	0.03
283	43.687	0.152	2.34	101.6	1.7	-	84	-0.041	5.49	0.03
284	43.845	0.158	2.34	101.6	1.95	-	84	-0.042	5.66	0.05
285	43.997	0.152	2.34	101.6	2.02	-	84	-0.041	7.47	0.01
286	44.152	0.155	2.34	101.6	2.07	-	84	-0.039	7.63	0.01
287	44.305	0.153	2.34	101.8	1.7	-	84	-0.038	5.62	0.01

BOX B TEST DATA - ASTM E2779 / ASTM E2515

Client: Laminox
 Model: Phenix
 Run #: 1

Job #: 23-209
 Tracking #: 163
 Technician: AK
 Date: 10/16/2023

Elapsed Time (min)	Particulate Sampling Data							Flue Gas Data		
	Gas Meter (ft ³)	Sample Rate (cfm)	Orifice dH (in H ₂ O)	Meter Temp (°F)	Meter Vacuum (in Hg)	Pro. Rate (%)	Filter (°F)	Flue Draft (in H ₂ O)	CO ₂ (%)	CO (%)
288	44.461	0.156	2.34	101.9	1.97	-	84	-0.038	5.55	0.02
289	44.616	0.155	2.33	101.9	1.75	-	84	-0.039	5.31	0.01
290	44.769	0.153	2.33	101.9	1.84	100	84	-0.040	4.90	0.02
291	44.924	0.155	2.34	101.8	1.65	-	84	-0.036	5.40	0.02
292	45.077	0.153	2.33	101.9	1.98	-	84	-0.039	5.16	0.03
293	45.234	0.157	2.34	102	2.11	-	84	-0.040	6.27	0.02
294	45.386	0.152	2.34	102.2	1.65	-	84	-0.039	7.34	0.01
295	45.541	0.155	2.34	102.3	2.16	-	84	-0.041	5.72	0.02
296	45.694	0.153	2.33	102.3	1.82	-	84	-0.043	5.55	0.01
297	45.850	0.156	2.34	102.3	2.02	-	84	-0.039	6.07	0.03
298	46.005	0.155	2.33	102.3	2.16	-	84	-0.040	5.11	0.03
299	46.157	0.152	2.33	102.4	1.77	-	83	-0.041	5.05	0.04
300	46.313	0.156	2.33	102.4	1.65	99	83	-0.040	4.78	0.03
301	46.466	0.153	2.33	102.3	1.95	-	83	-0.039	4.25	0.04
302	46.622	0.156	2.33	102.3	1.85	-	83	-0.038	6.56	0.02
303	46.774	0.152	2.34	102.4	1.95	-	83	-0.040	5.51	0.02
304	46.930	0.156	2.33	102.3	2.1	-	83	-0.042	4.27	0.04
305	47.082	0.152	2.32	102.3	1.89	-	83	-0.039	5.16	0.03
306	47.238	0.156	2.33	102.3	2.11	-	83	-0.041	6.61	0.03
307	47.393	0.155	2.34	102.3	2.19	-	83	-0.038	5.96	0.02
308	47.545	0.152	2.33	102.4	2.12	-	83	-0.038	5.23	0.01
309	47.701	0.156	2.33	102.4	1.74	-	83	-0.041	5.45	0.01
310	47.853	0.152	2.32	102.5	1.72	97	83	-0.038	4.80	0.02
311	48.010	0.157	2.32	102.3	1.72	-	83	-0.041	4.41	0.02
312	48.162	0.152	2.33	102.2	1.68	-	83	-0.036	6.43	0.03
313	48.317	0.155	2.33	102.3	2.14	-	83	-0.040	6.04	0.02
314	48.469	0.152	2.32	102.2	1.67	-	83	-0.040	5.15	0.01
315	48.625	0.156	2.32	102.3	1.71	-	83	-0.039	4.40	0.03
316	48.779	0.154	2.32	102.3	1.74	-	83	-0.039	4.94	0.03
317	48.932	0.153	2.33	102.3	1.7	-	83	-0.040	7.86	0.00
318	49.088	0.156	2.32	102.3	2.14	-	83	-0.041	7.67	0.01
319	49.239	0.151	2.32	102.4	1.73	-	83	-0.039	5.57	0.03

BOX B TEST DATA - ASTM E2779 / ASTM E2515

Client: Laminox
 Model: Phenix
 Run #: 1

Job #: 23-209
 Tracking #: 163
 Technician: AK
 Date: 10/16/2023

Elapsed Time (min)	Particulate Sampling Data							Flue Gas Data		
	Gas Meter (ft ³)	Sample Rate (cfm)	Orifice dH (in H ₂ O)	Meter Temp (°F)	Meter Vacuum (in Hg)	Pro. Rate (%)	Filter (°F)	Flue Draft (in H ₂ O)	CO ₂ (%)	CO (%)
320	49.396	0.157	2.33	102.4	2.16	97	83	-0.038	4.63	0.07
321	49.549	0.153	2.33	102.3	1.87	-	83	-0.041	5.05	0.04
322	49.703	0.154	2.32	102.4	1.87	-	83	-0.039	5.51	0.05
323	49.856	0.153	2.32	102.3	1.75	-	83	-0.037	6.38	0.02
324	50.011	0.155	2.32	102.3	1.92	-	83	-0.038	5.78	0.03
325	50.166	0.155	2.32	102.4	2.19	-	83	-0.038	5.21	0.03
326	50.319	0.153	2.33	102.3	1.75	-	83	-0.036	6.99	0.01
327	50.474	0.155	2.33	102.3	2.05	-	83	-0.037	5.55	0.01
328	50.625	0.151	2.31	102.3	1.71	-	83	-0.041	5.92	0.01
329	50.782	0.157	2.33	102.3	1.65	-	83	-0.039	6.09	0.02
330	50.934	0.152	2.32	102.3	2.06	97	83	-0.038	5.67	0.02
331	51.090	0.156	2.33	102.3	1.84	-	83	-0.039	5.77	0.02
332	51.241	0.151	2.32	102.3	2.14	-	83	-0.038	4.63	0.04
333	51.396	0.155	2.32	102.3	1.82	-	83	-0.040	4.82	0.02
334	51.550	0.154	2.32	102.3	1.74	-	83	-0.040	4.41	0.02
335	51.704	0.154	2.32	102.3	1.67	-	83	-0.035	4.34	0.04
336	51.858	0.154	2.32	102.3	2.04	-	83	-0.040	3.79	0.03
337	52.010	0.152	2.32	102.3	1.69	-	83	-0.037	5.91	0.04
338	52.166	0.156	2.32	102.3	1.74	-	83	-0.037	4.56	0.02
339	52.318	0.152	2.32	102.4	1.91	-	83	-0.038	4.34	0.01
340	52.474	0.156	2.32	102.3	1.84	97	83	-0.038	5.39	0.01
341	52.625	0.151	2.32	102.3	1.83	-	83	-0.037	4.80	0.02
342	52.781	0.156	2.32	102.3	2.05	-	83	-0.042	4.35	0.01
343	52.933	0.152	2.31	102.3	1.91	-	83	-0.041	4.23	0.02
344	53.088	0.155	2.32	102.3	1.92	-	83	-0.039	7.66	0.02
345	53.243	0.155	2.32	102.3	2.21	-	83	-0.040	8.09	0.00
346	53.394	0.151	2.31	102.4	2.22	-	83	-0.037	6.53	0.01
347	53.549	0.155	2.32	102.3	2.21	-	82	-0.037	6.94	0.01
348	53.701	0.152	2.32	102.3	1.74	-	83	-0.039	6.63	0.02
349	53.857	0.156	2.32	102.2	1.71	-	83	-0.041	5.46	0.02
350	54.009	0.152	2.31	102.3	1.67	95	83	-0.037	4.08	0.02
351	54.164	0.155	2.32	102.2	1.94	-	82	-0.039	4.01	0.02

BOX B TEST DATA - ASTM E2779 / ASTM E2515

Client: Laminox
 Model: Phenix
 Run #: 1

Job #: 23-209
 Tracking #: 163
 Technician: AK
 Date: 10/16/2023

Elapsed Time (min)	Particulate Sampling Data							Flue Gas Data		
	Gas Meter (ft ³)	Sample Rate (cfm)	Orifice dH (in H ₂ O)	Meter Temp (°F)	Meter Vacuum (in Hg)	Pro. Rate (%)	Filter (°F)	Flue Draft (in H ₂ O)	CO ₂ (%)	CO (%)
352	54.315	0.151	2.32	102.3	1.71	-	82	-0.037	3.64	0.01
353	54.470	0.155	2.31	102.2	1.79	-	82	-0.039	6.62	0.01
354	54.624	0.154	2.32	102.2	1.7	-	82	-0.038	6.59	0.01
355	54.777	0.153	2.31	102.3	1.79	-	82	-0.038	6.15	0.02
356	54.931	0.154	2.32	102.2	2.08	-	82	-0.038	5.19	0.04
357	55.083	0.152	2.31	102.2	1.68	-	82	-0.040	4.94	0.04
358	55.238	0.155	2.31	102.2	2.05	-	83	-0.039	6.58	0.01
359	55.389	0.151	2.31	102.2	2.12	-	83	-0.037	5.88	0.01
360	55.545	0.156	2.31	102.1	2.15	95	82	-0.037	6.25	0.03
Avg/Tot	55.545	0.154	2.38	96	1.84	100			7.59	0.03

LAB SAMPLE DATA - ASTM E2515

Client: Laminox
 Model: Phenix
 Run #: 1

Job #: 23-209
 Tracking #: 163
 Technician: AK
 Date: 10/16/2023

		Sample ID	Tare, mg	Final, mg	Catch, mg
Filters	A	G00699	249.6	251.1	1.5
	B	G00700	240.2	242.1	1.9
	C - 1st Hour	G00701	240.3	241.1	0.8
	Amb	G00702	241.4	241.6	0.2
Probes	A	8A	116633.0	116633.9	0.9
	B	8B	116665.0	116666.0	1.0
	C - 1st Hour	8C	116662.7	116663.5	0.8
O-rings	A	8A	3552.8	3554.1	1.3
	B	8B	3357.8	3358.7	0.9
	C - 1st Hour	8C	3587.3	3587.9	0.6

Placed in Dessicator on: 10/16/2023

Balance Audit (mg): 200.0 200.0 200.0

		Weight (mg)	Date/Time	Weight (mg)	Date/Time	Weight (mg)	Date/Time	Weight (mg)	Date/Time
Filters	A	251.3	10/18 9:45	251.0	10/20 10:30	251.1	10/23 14:00		
	B	242.2	10/18 9:45	242.1	10/20 10:30				
	C - 1st Hour	241.1	10/18 9:45	241.1	10/20 10:30				
	Amb	241.5	10/18 9:45	241.6	10/20 10:30				
Probes	A	116634.1	10/18 9:45	116633.9	10/20 10:30				
	B	116666.0	10/18 9:45	116666.0	10/20 10:30				
	C - 1st Hour	116663.6	10/18 9:45	116663.5	10/20 10:30				
O-Rings	A	3554.2	10/18 9:45	3554.1	10/20 10:30				
	B	3358.8	10/18 9:45	3358.7	10/20 10:30				
	C - 1st Hour	3588.0	10/18 9:45	3587.9	10/20 10:30				

Train A Aggregate, mg:	3.7
Train B Aggregate, mg:	3.8
Train C Aggregate, mg:	2.2
Ambient Aggregate, mg:	0.2

ASTM E2779 Wood Heater Run Sheets

Client: Laminox Job Number: 23-209 Tracking #: 163
 Model: Phenix Run Number: 1 Test Date: 10/16/23

Pellet Heater Control Settings

High Burn Rate Settings: Air slide maximum
 Medium Burn Rate Settings: Air slide open 1/2"
 Low Burn Rate Settings: Air slide fully closed

Preburn Notes

Preburn Start Time: 9:03

Time	Notes
	-None-

Test Notes

Test Burn Start Time: 10:05

Time	Notes
60:00	Changed to medium setting Changed to low setting Test end
180:00	
360:00	

Test Burn End Time: 16:05

Flue Gas Concentration Measurement

Calibration Gas Values: Span Gas CO₂ (%): 17.10 CO (%): 4.306
 Mid Gas CO₂ (%): 10.09 CO (%): 2.530

Calibration Results:

	Pre Test			Post Test		
	Zero	Span	Mid	Zero	Span	Mid
Time	9:00	9:01	9:02	16:08	16:09	16:10
CO ₂	0.00	17.00	10.08	0.00	16.90	10.02
CO	0.000	4.306	2.503	-0.048	4.236	2.457

Flue Gas Probe Leak Check: Initial: 0 Final: 0

Technician Signature: 

Date: 11/22/2023
Page 1 of 1



LAMINOX S.r.l.
 Zona Industriale Callarella, 261-263
 62028 SARNANO (MC)
 ITALY

Pellet Stove Phenix Air



serial number

Listed solid fuel room heater/pellet type insert. Also suitable for mobile home installation. This appliance has been tested and listed for use in Manufactured Homes in accordance with OAR 814-23-9000 through 814-23-909.

Tested to: ASTM 1509, ORD-C-1482-M1990 Room Heating Pellet Burning Type, APFI, (UM) 84-HUD FOR USE ONLY WITH PELLETTIZED WOOD OR SHELLLED FIELD CORN FUEL.

This wood heater needs periodic inspection and repair for proper operation. Consult the owner's manual for further information. It is against federal regulations to operate this wood heater in a manner inconsistent with the operating instructions in the owner's manual.

Route power cord away from unit. Do not route cord under or in front of appliance.

DANGER: Risk of electrical shock. Disconnect power supply before servicing. Replace glass only with 5 mm ceramic available from your dealer. To start, set thermostat above room temperature, the stove will light automatically. To shutdown, set thermostat to below room temperature. For further instruction refer to owner's manual. Keep viewing and ash removal doors tightly closed during operation.

PREVENT HOUSE FIRES

Install and use only in accordance with manufacturer's installation and operating instructions. Contact local building or fire officials about restrictions and inspection in our area.

WARNING - FOR MOBILE HOMES: Do not install appliance in a sleeping room. An outside combustion air inlet must be provided. The structural integrity of the mobile home floor, ceiling and walls must be maintained. Refer to manufacturer's instructions and local codes for precautions required for passing chimney through a combustible wall or ceiling. Inspect and clean vent system frequently in accordance with manufacturer's instructions.

DO NOT CONNECT THIS UNIT TO A CHMNEY SERVING ANOTHER APPLIANCE

Use a 3" or 4" diameter type "L" or "PL" venting system.

MINIMUM CLEARANCES TO COMBUSTIBLE MATERIALS

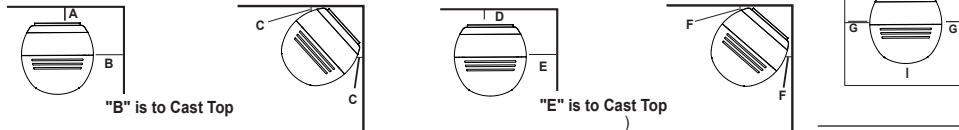

"B" is to Cast Top

"E" is to Cast Top

FLOOR PROTECTION

*Non-combustible floor protection must extend beneath the flue pipe when installed with horizontal venting or under the Top Vent Adapter with vertical Installation.

RECOMMENDED IN USA

Floor protector must be non combustible material, extending beneath heater and to the front/sides/rear as indicated. Measure front distance (I) from the surface of the glass door.

Note 1: In residential installations, when using parts 811-0890, (3"-3" Top vent adapter) and 812-3570 (3"-6" offset adapter), 24 gauge 6" single wall flue connector may be used.

Note 2: In manufactured home installation, when using Part 811-0890, (3"-3" Top Vent Adapter) and 812-3570 (3"-6" offset adapter), use listed double wall flue connector. An Outside Air Kit (Part 811-0872), must be used with manufactured home installation.

A Back wall to stove 8"/200 mm
 B Side wall to Cast Top 20"/500 mm

CORNER INSTALLATION

C Side wall 8"/200 mm
 VERTICAL 3"-6" ADAPTER KIT (PART 812-3570)Installation:
 D Back wall to Flue Pipe 21"/550 mm
 E Side wall to Cast Top 20"/500 mm

CORNER INSTALLATION WITH VERTICAL ADAPTER KIT:
 F Side wall: 8"/200 mm

ALCOVE INSTALLATION

Min Alcove Height: 43"/1092 mm
 Min Alcove Side Wall: 6"/152 mm
 Max Alcove Depth: 36"/914 mm

U.S. ENVIROMENTAL PROTECTION AGENCY

Certified to comply with 2020 particulate emission standards using pellet wood.

Emission Rate (g/hr)	Heating Efficiency (% Overall)	1st hour Emission Rate (g/hr)	CO emission (g/hr)
1,3	79,0	4,9	4,8

2023	2024	2025	Jan.	Feb.	Mar.	Apr.	May	June	July	Aug	Sept	Oct	Nov	Dec
<input type="checkbox"/>	<input type="checkbox"/>	<input type="checkbox"/>	<input type="checkbox"/>	<input type="checkbox"/>	<input type="checkbox"/>	<input type="checkbox"/>	<input type="checkbox"/>	<input type="checkbox"/>	<input type="checkbox"/>	<input type="checkbox"/>	<input type="checkbox"/>	<input type="checkbox"/>	<input type="checkbox"/>	<input type="checkbox"/>

DO NOT REMOVE THIS LABEL Made in Italy



LAMINOX S.r.l.
 Zona Industriale Callarella, 261-263
 62028 SARNANO (MC)
 ITALY

Pellet Stove Lydia Natural



serial number

Listed solid fuel room heater/pellet type insert. Also suitable for mobile home installation. This appliance has been tested and listed for use in Manufactured Homes in accordance with OAR 814-23-9000 through 814-23-909.

Tested to: ASTM 1509, ORD-C-1482-M1990 Room Heating Pellet Burning Type, APFI, (UM) 84-HUD FOR USE ONLY WITH PELLETTIZED WOOD OR SHELLLED FIELD CORN FUEL.

This wood heater needs periodic inspection and repair for proper operation. Consult the owner's manual for further information. It is against federal regulations to operate this wood heater in a manner inconsistent with the operating instructions in the owner's manual.

Route power cord away from unit. Do not route cord under or in front of appliance.

DANGER: Risk of electrical shock. Disconnect power supply before servicing. Replace glass only with 5 mm ceramic available from your dealer. To start, set thermostat above room temperature, the stove will light automatically. To shutdown, set thermostat to below room temperature. For further instruction refer to owner's manual. Keep viewing and ash removal doors tightly closed during operation.

PREVENT HOUSE FIRES

Install and use only in accordance with manufacturer's installation and operating instructions. Contact local building or fire officials about restrictions and inspection in our area.

WARNING - FOR MOBILE HOMES: Do not install appliance in a sleeping room. An outside combustion air inlet must be provided. The structural integrity of the mobile home floor, ceiling and walls must be maintained. Refer to manufacturer's instructions and local codes for precautions required for passing chimney through a combustible wall or ceiling. Inspect and clean vent system frequently in accordance with manufacturer's instructions.

DO NOT CONNECT THIS UNIT TO A CHMNEY SERVING ANOTHER APPLIANCE

Use a 3" or 4" diameter type "L" or "PL" venting system.

MINIMUM CLEARANCES TO COMBUSTIBLE MATERIALS

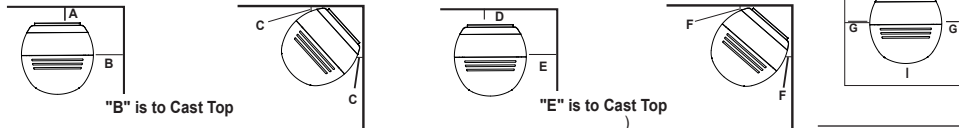

"B" is to Cast Top

"E" is to Cast Top

FLOOR PROTECTION

*Non-combustible floor protection must extend beneath the flue pipe when installed with horizontal venting or under the Top Vent Adapter with vertical Installation.

RECOMMENDED IN USA

Floor protector must be non combustible material, extending beneath heater and to the front/sides/rear as indicated. Measure front distance (I) from the surface of the glass door.

Note 1: In residential installations, when using parts 811-0890, (3"-3" Top vent adapter) and 812-3570 (3"-6" offset adapter), 24 gauge 6" single wall flue connector may be used.

Note 2: In manufactured home installation, when using Part 811-0890, (3"-3" Top Vent Adapter) and 812-3570 (3"-6" offset adapter), use listed double wall flue connector. An Outside Air Kit (Part 811-0872), must be used with manufactured home installation.

A Back wall to stove 8"/200 mm
 B Side wall to Cast Top 20"/500 mm

CORNER INSTALLATION

C Side wall 8"/200 mm
 VERTICAL 3"-6" ADAPTER KIT (PART 812-3570)Installation:
 D Back wall to Flue Pipe 21"/550 mm
 E Side wall to Cast Top 20"/500 mm

CORNER INSTALLATION WITH VERTICAL ADAPTER KIT:
 F Side wall: 8"/200 mm

ALCOVE INSTALLATION

Min Alcove Height: 43"/1092 mm
 Min Alcove Side Wall: 6"/152 mm
 Max Alcove Depth: 36"/914 mm

U.S. ENVIROMENTAL PROTECTION AGENCY

Certified to comply with 2020 particulate emission standards using pellet wood.

Emission Rate (g/hr)	Heating Efficiency (% Overall)	1st hour Emission Rate (g/hr)	CO emission (g/hr)
1,3	79,0	4,9	4,8

2023	2024	2025	Jan.	Feb.	Mar.	Apr.	May	June	July	Aug.	Sept.	Oct.	Nov.	Dec.
<input type="checkbox"/>	<input type="checkbox"/>	<input type="checkbox"/>	<input type="checkbox"/>	<input type="checkbox"/>	<input type="checkbox"/>	<input type="checkbox"/>	<input type="checkbox"/>	<input type="checkbox"/>	<input type="checkbox"/>	<input type="checkbox"/>	<input type="checkbox"/>	<input type="checkbox"/>	<input type="checkbox"/>	<input type="checkbox"/>

DO NOT REMOVE THIS LABEL Made in Italy



USE AND MAINTENANCE INSTRUCTIONS

PELLET STOVE WITH NATURAL DRAFT

Phenix Air

SAVE THIS INSTRUCTIONS

WARNING: Please read this entire manual before installation and use of this pellet fuel-burning room heater.
Failure to follow these instructions could result in property damage, bodily injury or even death

CAUTION: Contact local building or fire official about restrictions and installation inspection requirement in your area

Dear Customer, thank you for choosing one of our products, which is a result of technological expertise and our continuous quest for superior products in terms of safety, reliability and performance. This manual contains all the information and helpful tips for using your product with maximum safety and efficiency.

IMPORTANT INFORMATION

This manual has been prepared by the manufacturer and is an integral and essential part of the product. In the event of sale or transfer of the product, always ensure the presence of the manual as the information it contains is addressed to the purchaser and to all those various people involved in the installation, use and maintenance of the product. Carefully read the instructions and information contained in this manual before installation, operation and maintenance of the product. The instructions contained in this instruction manual guarantee the safety of persons and property and ensure efficient operation and a longer service life. The manufacturer declines all responsibility for damage caused by failure to observe instructions regarding installation, use and maintenance listed in the instruction manual, for unauthorised modifications or non-original replacement parts. Product installation and use must be carried out in accordance with the manufacturer's instructions and in compliance with European, national and local regulations. Installation, electrical connection, functional testing, maintenance and repairs are operations that must be performed by qualified and licensed personnel who must have appropriate knowledge of the product. Product installation must not be carried out close to walls made of wood or combustible material. For proper installation, you must observe the following "Safety distances" section. Verify the exact flatness of the floor where you will install the product. When handling the steel parts of the cladding, use clean cotton gloves to avoid leaving difficult to remove fingerprints for the first cleaning. Stove installation must be performed by at least two people. Connect the stove to the mains only after proper professional connection to the chimney flue. The power cable plug must remain accessible after installation of the stove. Only operate the stove with regulation wood pellets (refer to the "FUEL" chapter). Never use liquid fuels to operate the pellet stove or to stoke the embers present. Provide adequate ventilation in the installation area throughout the year. In the presence of operation failures, fuel supply will be interrupted. Re-start the unit after removing the cause of the failure. Discontinue use of the product in the event of failure or malfunction. Do not remove the safety guard located in the pellet tank. Any accumulated unburned pellets in the burner as a result of repeated "failed ignitions must be removed prior to ignition." Pellet stove operation can cause very hot heating of the handles, the chimney flue and glass surfaces. Only touch these parts during operation when wearing protective clothing or with adequate aids. Because of the creation of heat on the glass, make sure that no persons unfamiliar with stove operation stand in the installation area. Inform children of the precautions to be observed during product operation and of possible dangers. In the event of problems or misunderstanding of the instruction manual, contact your dealer. Placing objects which cannot withstand heat on the stove or within the minimum required safety range is prohibited. Do not open the door during operation or operate the stove with its glass broken. For product terms, limitations and exclusions, please refer to the warranty included with the product. In order to pursue a policy of constant product development and renewal, the manufacturer may make changes to it as deems appropriate without notice. This document is the property of the manufacturer and cannot be disclosed in whole or in part to any third party without the written consent of the company, which reserves all rights to the rigor of the law.

1	GENERAL STANDARDS	4
1.1	Fireplace or Chimney flue	4
1.2	Chimney cap	5
1.3	External air intake vent	6
1.4	Connection to the chimney flue	6
1.5	Preventing house fires	6
2	SPECIFICATIONS AND TECHNICAL DATA	7
2.1	Specifications	7
2.2	Compliance status	7
2.3	Technical data	7
2.4	Product identification data	7
3	FUEL	8
3.1	General notes	8
4	INSTALLATION	9
4.1	General notes	9
4.2	Minimum safety distances	10
4.3	Flooring protection	12
4.4	Minimum distances for positioning air intake vents	12
4.5	Vent exhaust duct	12
4.6	Using an external fume duct	14
5	ASSEMBLY	14
5.1	General notes	14
5.2	Unpacking	14
6	USE	15
6.1	Components	16
6.2	Filling up the tank	16
6.3	Ignition	17
6.4	Combustion mode	17
6.5	Shutdown	18
6.6	Cleaning the exchanger	18
6.7	Cleaning the brazier with the shaker	19
7	WARNINGS AND MAINTENANCE	20
7.1	Opening the door	20
7.2	Ashes cleaning and disposal	20
7.3	Brazier cleaning	20
7.4	Ash drawer cleaning	21
7.5	Combustion chamber cleaning	21
7.6	Smoke chamber cleaning	21
7.7	Exhaust system cleaning	21
7.8	Cleaning metal and ceramic parts	21
7.9	Pellet slide cleaning	21
7.10	Cleaning glass	22
7.11	Broken glass	22
7.12	Stove inactivity	22
7.13	Routine and special maintenance	22
7.14	Routine maintenance performed by qualified technicians	23
7.15	Spare parts replacement	23
8	WARRANTY	27
8.1	Certificate of warranty	27
8.2	Condition of warranty	27
8.3	Information and problems	27

1 GENERAL STANDARDS

1.1 Fireplace or Chimney flue

Each device must have a vertical duct, called a chimney flue, for outside release of combustion fumes produced by a natural draft.

The chimney flue must meet the following requirements:

- It should not be connected to any other fireplace, stove, boiler, or hood of any kind (Fig. 1).
- It must be properly spaced from combustible or flammable materials through an air gap or suitable insulating material.
- The internal section must be uniform, preferably circular: the square or rectangular sections must have rounded corners, curves must be regular and seamless, deviations from the axis no greater than 45° (Fig-2).
- Each device must have its own chimney flue with a section equal to or greater than the diameter of the fume exhaust pipe of the stove and a height no less than the one stated (see table 2).
- Never use two stoves, a fireplace and a stove, a stove and a wood stove, etc. in the same room since the draft of one could damage the draft of the other. In addition, collective ventilation ducts that can cause a vacuum in the installation environment are not permitted, even if installed in adjacent rooms and communicating with the installation room.
- Creating fixed or mobile apertures on the chimney flue to connect equipment other than auxiliary devices is prohibited.
- Passing other air supply channels and piping for utilities through the chimney flue, however large, is prohibited.
- The chimney flue should be equipped with a collection chamber for solid materials and any condensate, located below the mouth of the flue, so as to be easily opened and inspected from an airtight door.
- Whenever using parallel output chimneys, it is advisable to raise a bracing element. (Fig.3)

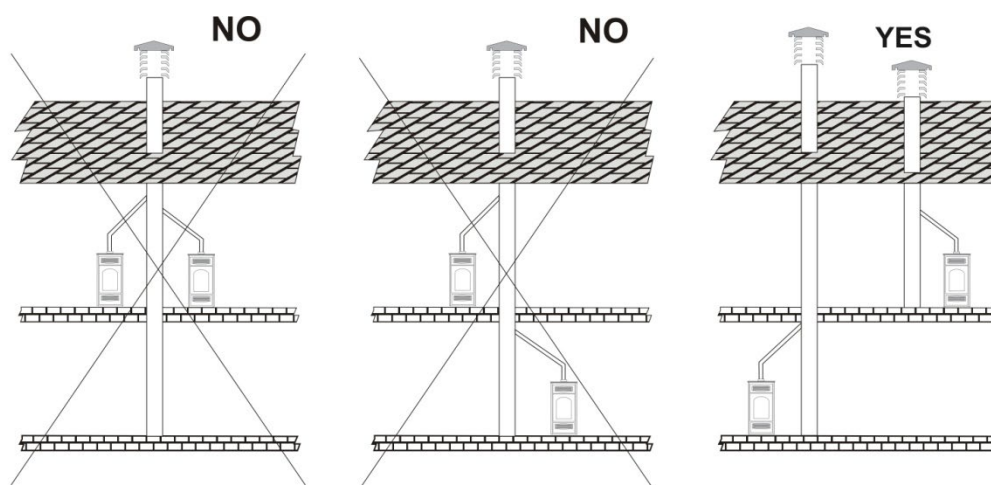

Fig 1

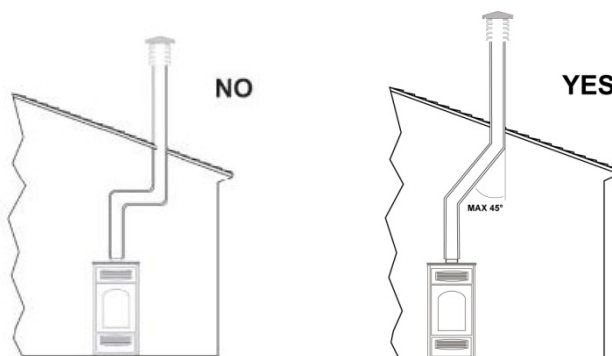

Fig 2

1.2 Chimney cap

The top of the chimney flue must be equipped with a device, called a chimney cap, which facilitates dispersion into the atmosphere of combustion products.

The chimney cap must meet the following requirements:

- Its internal section and shape must be equivalent to that of the chimney flue.
- Have a useful outlet section no less than double that of the chimney flue.
- Chimney caps that emerge from the roof or which remain in contact with the outside (for example in the case of an open loft), must be covered with brick elements and well isolated. It must be constructed so as to prevent penetration into the flue of rain, snow, or foreign bodies and so that, in the event of winds in any direction and at any angle, it assures the discharge of combustion products (windproof chimney cap).
- The chimney cap must be positioned so as to guarantee an adequate dispersion and dilution of combustion products and, in any case, outside the zone of reflux. This zone can be different sizes and shapes depending on the angle of slope of the roof, so it is necessary to adopt the minimum heights shown in Fig.3 and Fig.4.
- The chimney cap must be of windproof and exceed the height of the ridge, Fig.3 and Fig.4.
- Any buildings or other obstacles that exceed the height of the chimney cap must not be close to the chimney cap itself (Fig.3).

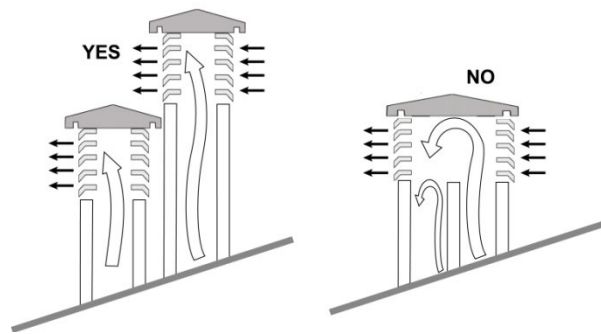

Fig.3

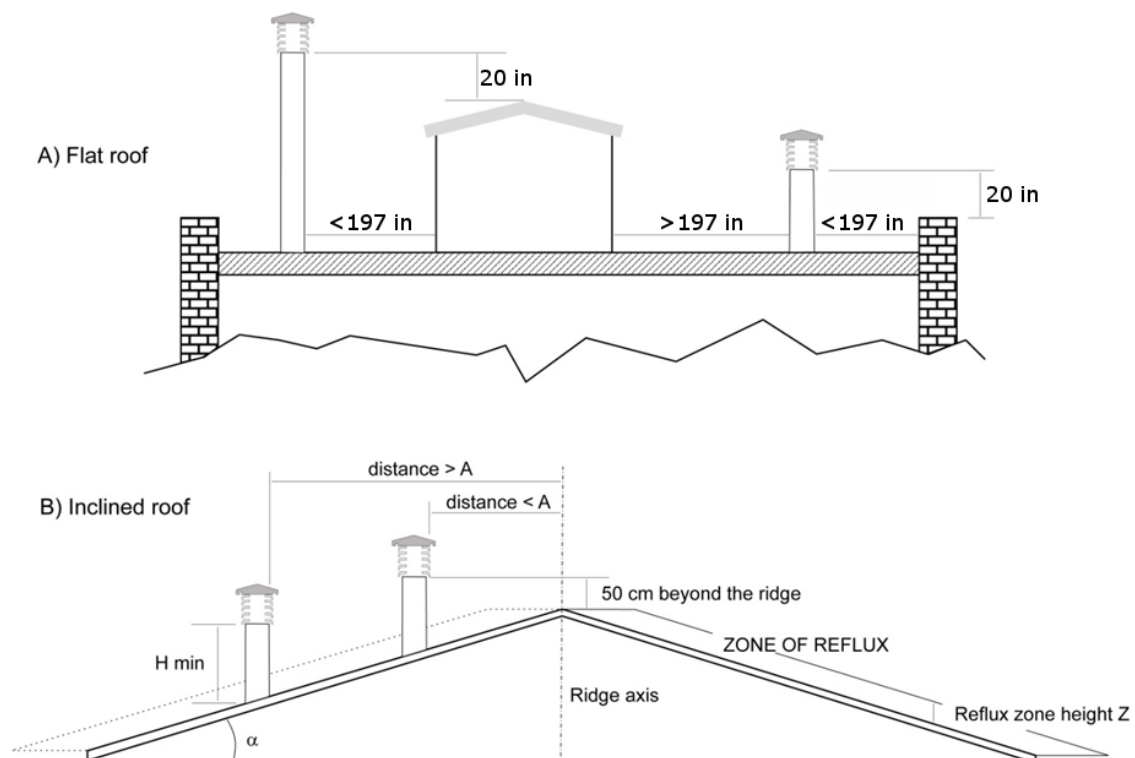

Fig.4

Roof pitch ? [°]	Horizontal width of the zone of reflux from the axis of the ridge A	Minimum height of the outlet from the roof	Height of the reflux zone Z
15	6 feet (1.85m)	3 feet (1.00m)	1 foot (0.50m)
30	5 feet (1.50m)	4 feet (1.30m)	2 feet (0.80m)
45	4 feet (1.30m)	6 feet (2.00m)	5 feet (1.50m)
60	4 feet (1.20m)	8 feet (2.60m)	7 feet (2.10m)

Table 2

1.3 External air intake vent

- The stove must have the air necessary to ensure smooth combustion operation and good environmental well-being.
- Make sure that the room where the stove is installed offers sufficient ventilation and install an air supply duct from the outside with the recommended minimum section of 15 in².
- The air intake vent must communicate directly with the installation room of the stove, positioned so as to prevent it from being blocked and protected with a permanent non-lockable grid or other suitable protection provided that it does not reduce the minimum section.
- Air flow can also be obtained from a room adjacent to the installation room, provided that this flow can be carried out freely through permanent, non-closable openings communicating with the outside.
- With respect to the installation room, the adjacent room should not be put under vacuum with respect to the external environment as a result of a reverse draft caused by the presence in this space of another utility device or suction device. The room adjacent to the permanent openings must meet the requirements set out in the paragraphs above. The adjacent room cannot be used as a garage, for storage of combustible material or for activities involving a risk of fire.

1.4 Connection to the chimney flue

(See paragraph 4.5)

1.5 Preventing house fires

Installation and use of the stove must be in accordance with the manufacturer's instructions and with local habitability regulations.

CAUTION: when a fume exhaust pipe passes through a wall or ceiling, particular installation methods must be applied (protection, thermal insulation, distances from heat sensitive materials, etc.).

- The fireplace connecting tube must never pass through a combustible surface.
- Do not connect this unit to a chimney flue already being used by another device.
- It is also advisable to maintain all combustible elements or flammable material such as beams, wooden furniture, curtains, flammable liquids, etc. outside the radiation area of the furnace and at a distance of at least 3 feet from the heating block.
- In the event that the surrounding space has coverings in combustible or heat-sensitive material, a protective membrane made of non-combustible insulating material must be interposed. If the flooring is made of combustible material, a non-combustible protective material must be provided at the mouth of the furnace.
- For further information, refer to local requirements.

2 SPECIFICATIONS AND TECHNICAL DATA

2.1 Specifications

Stoves and pellet stoves are devices built to work with good quality wood pellets only (see par. 3 fuel).

2.2 Compliance status

The heaters described in this manual meet the 2020 U.S. Environmental Protection Agency's wood pellet emission limit for wood heaters sold after May 15th 2015.

	Emission Rate (g/hr)	Heating Efficiency (% Overall) *	1st hour Emission Rate (g/hr)	CO emission (gr/h)
Phenix Air	1,3	79	4,9	4,8

* Efficiency Calculated Per CSA B415.1

2.3 Technical data

Model of type	Phenix Air
Pellet hourly consumption (min/max)	2,2-4,4 lb/h
Efficiency	79%
Hopper capacity	33 lb
Smoke outlet ø	5.9 in
Weight	330 lb
Dimension (DxWxH)	19,2x21,4x53 in

*Pellet size may affect actual rate of fuel feed and burn times. Fuel feed rates may vary by as much as 20%. Follow Manufacturer instructions and Use PFI certified pellet fuels to maximize efficiency.

2.4 Product identification data

The technical label shows device data and performance. Tampering with, removing or lack of a technical label makes installation and maintenance operations difficult, due to the lack of product identification. In the event of damage, request a duplicate from our service centre. Given the importance of the data label, we recommend installing the stove at a distance at which it is always visible.

3 FUEL

3.1 General notes

The pellet stove is designed to burn wood pellets only.

Wood pellets are a fuel obtained from the pressing of sawdust timber, extracted from the processing and transformation residues of dried wood material. The compactness of the product over time is guaranteed by a natural origin substance contained in the wood: lignin. The typical small cylinder form is obtained by extrusion.

Various types of pellets with quality and characteristics that vary depending on the processing and type of wood species used are available on the market.

CAUTION: Always use certified quality wood pellets: i.e. DIN, DIN PLUS, ÖM 7135, Pellet Gold, Catas etc. The company does not guarantee proper stove functioning with the use of low-quality pellets.

Stoves and heating stoves are tested and programmed to ensure good performance and perfect quality operation with specific characteristic pellets:

components:	wood
length:	< 30 mm
diameter:	6-6.5 mm
lower calorific value:	≥ 4.8 kWh/kg (≥7500 BTU/lb)
humidity rate:	< 8 %
residual ash:	< 0.5 %

GOOD QUALITY pellets are smooth, shiny, slightly dusty and with regular length. LOW QUALITY pellets are of varied lengths, dusty with vertical and horizontal splits.

Since pellet characteristics and quality greatly influence the autonomy, efficiency and proper operation of the stove, we recommend:

AVOID using pellets with dimensions different from that described by the manufacturer.

AVOID using low quality pellets or pellets containing dispersed sawdust powder, resins or chemicals, additives or adhesives.

AVOID using moist pellets.

The use of unsuitable pellets causes:

- clogging of the brazier and fume discharge ducts
- increased consumption of fuel
- decreased efficiency
- no guarantee of normal stove operation
- dirtying of glass
- production of unburned granules and heavy ash

The presence of moisture in pellets increases the volume of the capsules and crumbles, causing

- feeding system malfunctions
- poor combustion

Pellets should be stored in a dry and sheltered place. Particular attention should be given to the handling of the bags to prevent their crushing, resulting in the formation of sawdust.

Stove operation parameters may have to be altered when using quality pellets with dimensional and calorific characteristics different from those indicated. Contact an authorised service centre if necessary.

The use of poor-quality pellets not in accordance with manufacturer's instructions not only damage the stove and compromise performance but may result in forfeiture of the warranty and company liability.

Follow Manufacturer instructions and Use PFI certified pellet fuels to maximize efficiency.

4 INSTALLATION

4.1 General notes

WARNING: DO NOT INSTALL IN SLEEPING ROOM

The stove requires a UL listed pellet vent. So the venting system shall be approved for pellet stoves by a certified testing Laboratory

4.1.1 Installation in the presence of several appliances.

The presence of several appliances powered with different fuels, as well as hoods with or without extractor, must be evaluated during preventive checks and during the start up test in order to detect any variation compared to the design conditions or any aspect that cannot be detected during the design phase. The room must be well-ventilated according to the instructions of every single device. The external air intake vent must meet the requirements of paragraphs 1.3 and 4.4

The stove must not be used simultaneously with other generators that collect air from the environment even if installed in adjoining or communicating rooms

4.1.2 Suitability of the installation rooms

- Installing the device inside garage, store for combustible materials or rooms at risk of fire is prohibited.
- If the flooring is made of wood, provide a floor protection surface in compliance with current national standards
- Outdoor installation is prohibited, as well as exposure to atmospheric agents or humid areas.
- Locating the stove in a room with an explosive atmosphere is prohibited

4.1.3 Fume discharge system

Every device must be connected to a fume discharge system, which ensures dispersion of combustion products into the atmosphere.

The combustion products must be discharged from the roofs. Direct wall discharge or towards closed spaces, even in open air, is prohibited.

The components must be made of material with A1 fire reaction class. In particular, the use of metal extendible and flexible hoses is prohibited.

CAUTION: ensure that the plug for electrical connection remains accessible after the stove installation.

4.2 Minimum safety distances

The following figures show the minimum safety distances, which must always be guaranteed.

4.2.1 Corner installation

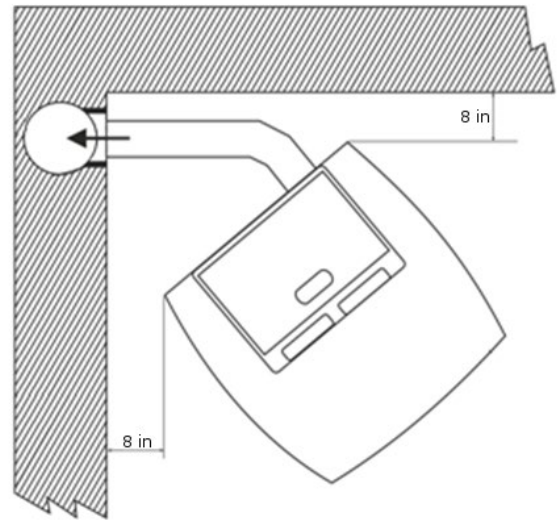

4.2.2 Wall installation

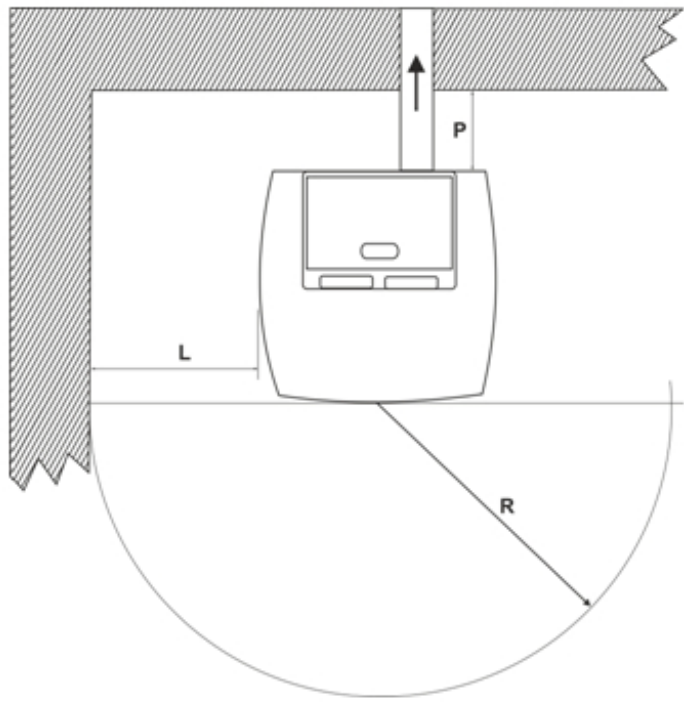

Safety distances from flammable material:

- Minimum distance in air from the flammable rear wall **P = 8 in**
- Minimum distance in air from the flammable side wall **L = 8 in**
- Frontal distance from flammable material **R = 40 in**

4.2.3 Distance from flammable ceilings and false ceilings

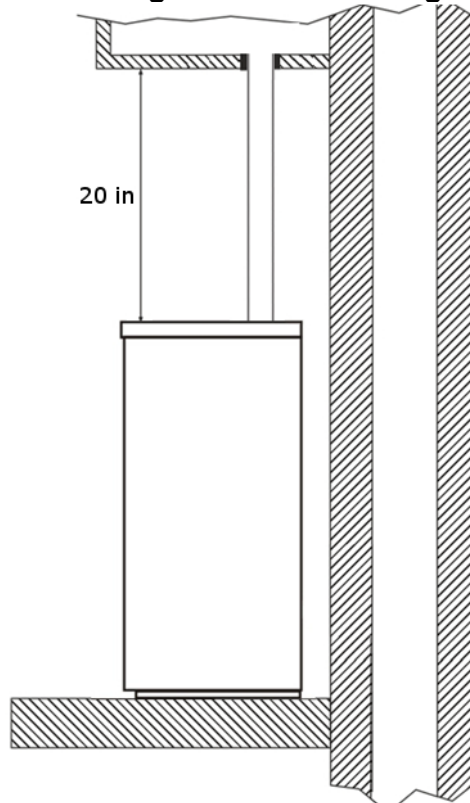

4.2.4 Distance of fume exhaust system from flammable walls

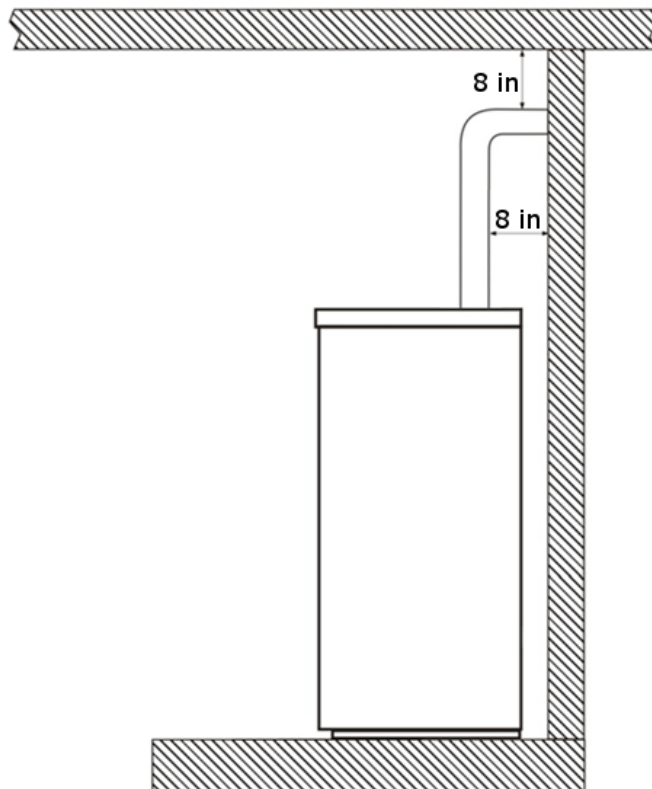

4.3 Flooring protection

In the event of valuable flooring or flooring that is sensitive to heat, moisture or is flammable, a floor protection must be used (i.e. sheet steel, marble or tile slabs). Whichever type of protection selected, it must protrude at least 12 in from the front, at least 6 in from the sides of the stove, must withstand the weight of the stove and have a thickness of at least 2 mm (Fig. 5 and 6).

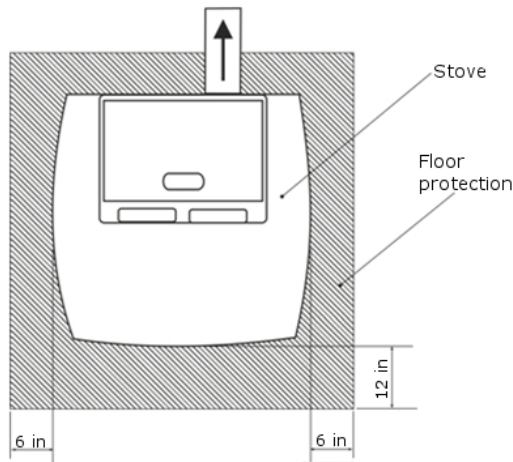

Fig. 5

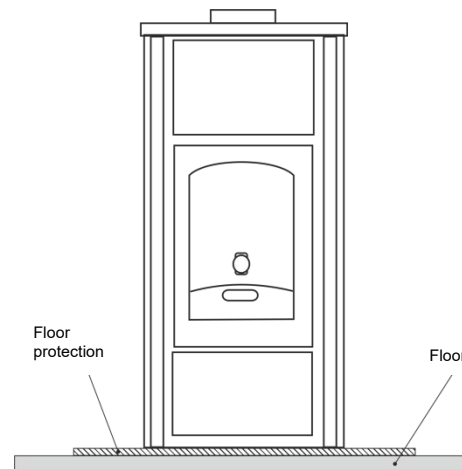

Fig. 6

4.4 Minimum distances for positioning air intake vents

Pellet stove combustion air intake vents cannot be connected to an air distribution system or directly to a wall-mounted air intake vent.

Correct and safe positioning of the air intake vent must comply with the measures and requirements described in paragraph 1.3.

There are distances to be respected in order to avoid that combustion air be removed by another source; for example, a window opening can suck the air outside, making it miss the stove.

The air intake vent must be located at least:		
5 feet (1.5 m)	Under	Doors, windows, fume exhaust outlets, air gaps, etc.
5 feet (1.5 m)	Horizontally away	
1 foot (0.3 m)	Over	
5 feet (1.5 m)	Away from	Fume output

4.5 Vent exhaust duct

4.5.1 General notes

The stove requires a UL listed pellet vent, so the venting system shall be approved for pellet stoves by a certified testing Laboratory

**DO NOT CONNECT THIS UNIT TO A CHIMNEY FLUE SERVING ANOTHER APPLIANCE
INSTALL VENT AT CLEARANCES SPECIFIED BY THE VENT MANUFACTURER**

Construction of the exhaust duct must be done by specialised personnel or companies, as reported in the following manual. Always create the exhaust system so that periodic cleaning is assured without having to dismantle any parts.

The chimney draft must be at least 6 Pa. The measurement must always be carried out with the device warm (nominal heat output)

If the draft exceeds 15 Pa, it is necessary to reduce it by installing a special device on the exhaust pipe or in the chimney, according to current regulations.

4.5.2 Tubes and maximum usable lengths

Painted aluminised steel tubes, stainless steel tubes (Aisi 316) or porcelain tubes. Flexible hoses are permitted if they fall within the limits prescribed by law (in stainless steel with smooth inner wall).

TYPE OF SYSTEM	WITH DOUBLE-WALL TUBE
Minimum length	10 feet (3 m)
Maximum length (with 3 90° curves)	26 feet (8 m)
Maximum number of curves	2

NOTE: load losses of a 90° curve can be equated with those of 1 metre of tube; the serviceable T- connection is to be considered as a 90° curve.

4.5.3 Holes for exhaust tube passage on walls or roof

Once the location of the stove has been decided (section 4.1), you will have to drill the hole for passage of the fume exhaust tube. This varies depending on the type of installation (therefore on the exhaust tube diameter, see 4.5.2) and on the type of wall or roof to be crossed (table 3).

The insulator must be of mineral origin (rock wool, ceramic fibre) with a nominal density greater than 80 kg/m³.

	Insulation thickness	Diameter of holes to be created [mm]
Wooden wall, or wall which is flammable or has flammable parts	4 in	12 in
Concrete wall or roof	2 in	9 in
Brick wall or roof	1,5 in	7 in

4.5.4 Using a traditional type chimney flue

If you wish to use an already existing chimney flue, it is advisable to have it checked by a professional chimney sweep to ensure that it is watertight. This is because fumes, being slightly pressurised, could infiltrate cracks in the chimney flue and invade living spaces. If an inspection finds that the chimney flue is not perfectly intact, it is advisable to intubate it with new material. If the existing chimney is large, we recommend inserting a tube with a maximum diameter of 6 in.

It is also advisable to insulate the vent exhaust duct. Figs. 7 and 8 demonstrate the solutions to adopt if you want to use an existing chimney flue.

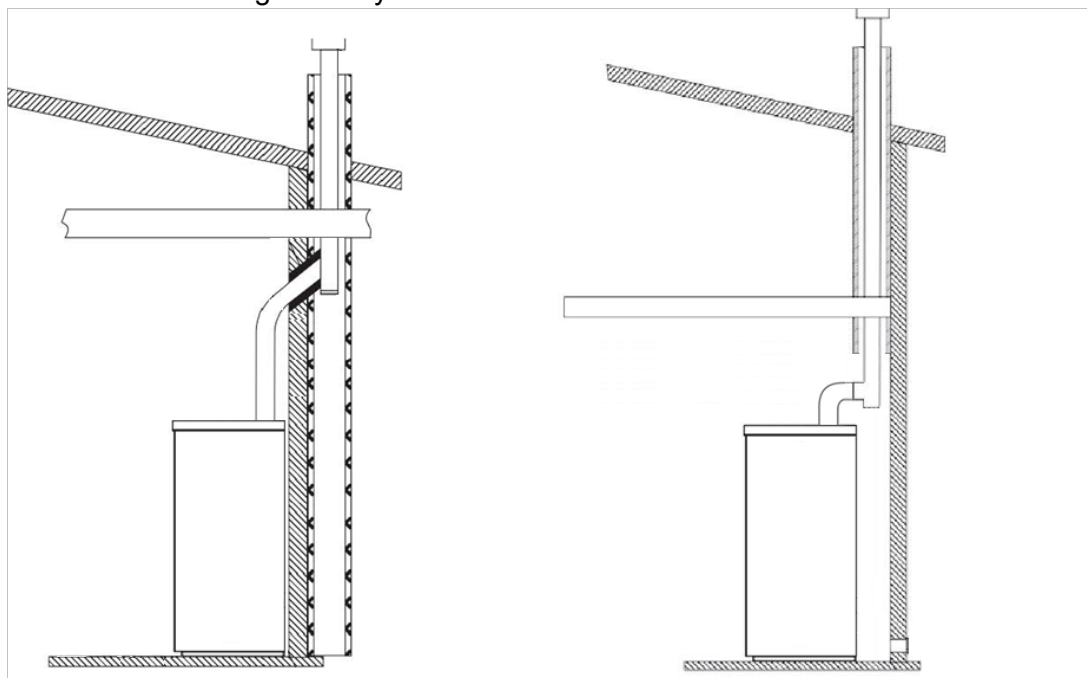

Fig. 7

Fig. 8

4.6 Using an external fume duct

An external fume duct can be used only if it meets the following requirements:

- Only insulated tubes (double wall) in stainless steel, secured to the building (Fig.9) should be used.
- An inspection area should be created at the base of the duct for performing periodic checks and maintenance.
- It should be equipped with a windproof chimney cap and observe the distance "d" from the ridge of the building as described in par. 1.2.
- Fig. 9 shows the solution to be utilised when using external fume ducts.

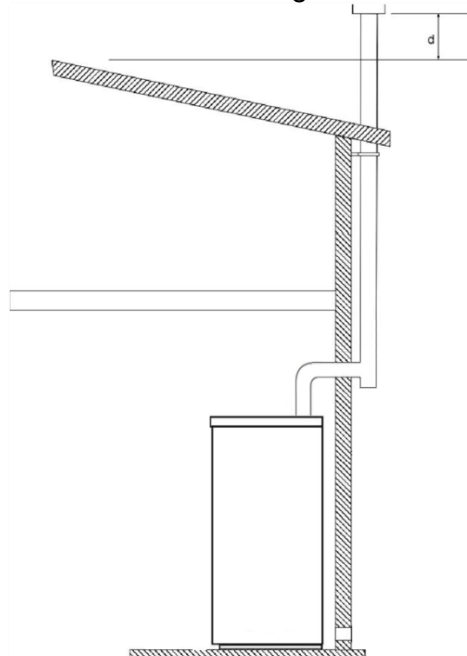

Fig. 9

5 ASSEMBLY

5.1 General notes

Here are some general recommendations to follow in order to prevent accidents or damage to the product:

- Unpacking and installation must be performed by at least two people.
- **All handling operations must be carried out using appropriate means and in full compliance with safety regulations.**
- The positioning of the packed product must be maintained in accordance with the guidelines supplied by pictograms and written on the packaging.
- If using ropes, straps, chains, etc., make sure they are suitable for the weight to be unloaded and are in good condition.
- When moving the package, move with slow and continuous movements to avoid tearing the ropes, chains, etc.
- Do not tilt excessively in order to avoid overturning.
- Do not stand within range of the loading/unloading means (forklifts, cranes, etc.).

5.2 Unpacking

Unpack the product being careful not to damage or scratch it. Remove the accessory package and any pieces of polystyrene or cardboard used to block removable parts, etc. from the stove furnace. Also remember not to leave packaging components (plastic bags, polystyrene, etc.) within the reach of children, as they could be potential sources of danger. Dispose of them according to regulations.

6 USE

- All local regulations, must be observed when installing the unit.
- Improper installation or use of the device can result in forfeiture of the warranty.
- Do not use the unit as an incinerator or in any other way other than that for which it was designed. No other fuel besides wood pellets must be used.
- Do not use liquid fuels.
- The device, especially the external surfaces, gets very hot to the touch when in use. Handle with care to avoid burns.
- Do not make any unauthorised modifications to the device.
- Only use original replacement parts recommended by the manufacturer.
- This wood heater has a manufacturer-set minimum low burn rate that must not be altered. It is against federal regulation to alter this setting or otherwise operate this wood heater in a manner inconsistent with operating instruction in this manual.
- This wood heater needs periodic inspection and repair for proper operation. It is against federal regulations to operate this wood heater in a manner inconsistent with operating instruction in this manual.
- Flues gases contain carbon monoxide (CO), it is recommended to install smoke monitors and CO monitors for areas that are expected to generated CO. Inspect the the chimney to minimize visible emissions.
- Soot and Flyash: Formation and Need for Removal—The products of combustion will contain small particles of flyash. The flyash will collect in the exhaust venting system and restrict the flow of the flue gases. Incomplete combustion, such as occurs during startup, shutdown, or incorrect operation of the room heater will lead to some soot formation which will collect in the exhaust venting system. The exhaust venting system should be inspected at least once every year to determine if cleaning is necessary.

In general

- Make sure that the room where the stove is to be installed offers sufficient ventilation (see section 1.3 “External air intake vent”).
- Periodically check (or have someone check) the cleanliness of exhaust fumes.
- When the stove is in operation, remove the extractable handle and place it in the appropriate compartment located at the rear of the stove (fig.11)
- **CAUTION: keep all flammable products well away from the stove when it operating (MINIMUM: 40 feet from the front wall).**
- **CAUTION: to prevent the escape of fumes, the combustion chamber must be kept closed except during cleaning operations, to be carried out with the stove off.**
- **CAUTION: removing the safety guard inside the tank is strictly prohibited.**
- **CAUTION: in the event of pellet supply while the stove is on, make sure that pellets are not finished and that the flame remains present in the brazier. Also avoid the fuel sack from coming into contact with hot surfaces.**
- **CAUTION: remove any residue of unburned pellets caused by failed ignitions before you start the stove again.**
- **CAUTION: if during the ignition phase, the stove does not start and you notice a lot of smoke in the combustion chamber, immediately turn off the stove and replace pellets in use, as these may be too high in moisture. Forcing ignition could make your stove a hazard.**
- **CAUTION: if during cleaning, you find traces of spongy or hard (though not ash) pellets, replace the pellets being used as this residue may come from scraps of low-quality sawdust not usable in this type of stove. Forcing ignition can cause a fire or strong production of fumes in the chimney.**
- **CAUTION: monitor proper combustion of the pellets in the brazier. If you should detect accumulations of unburned pellets, IMMEDIATELY TURN OFF the stove and contact the service centre.**
- **CAUTION: exercise extreme caution in the presence of children, to prevent them from standing in front of the stove.**

6.1 Components

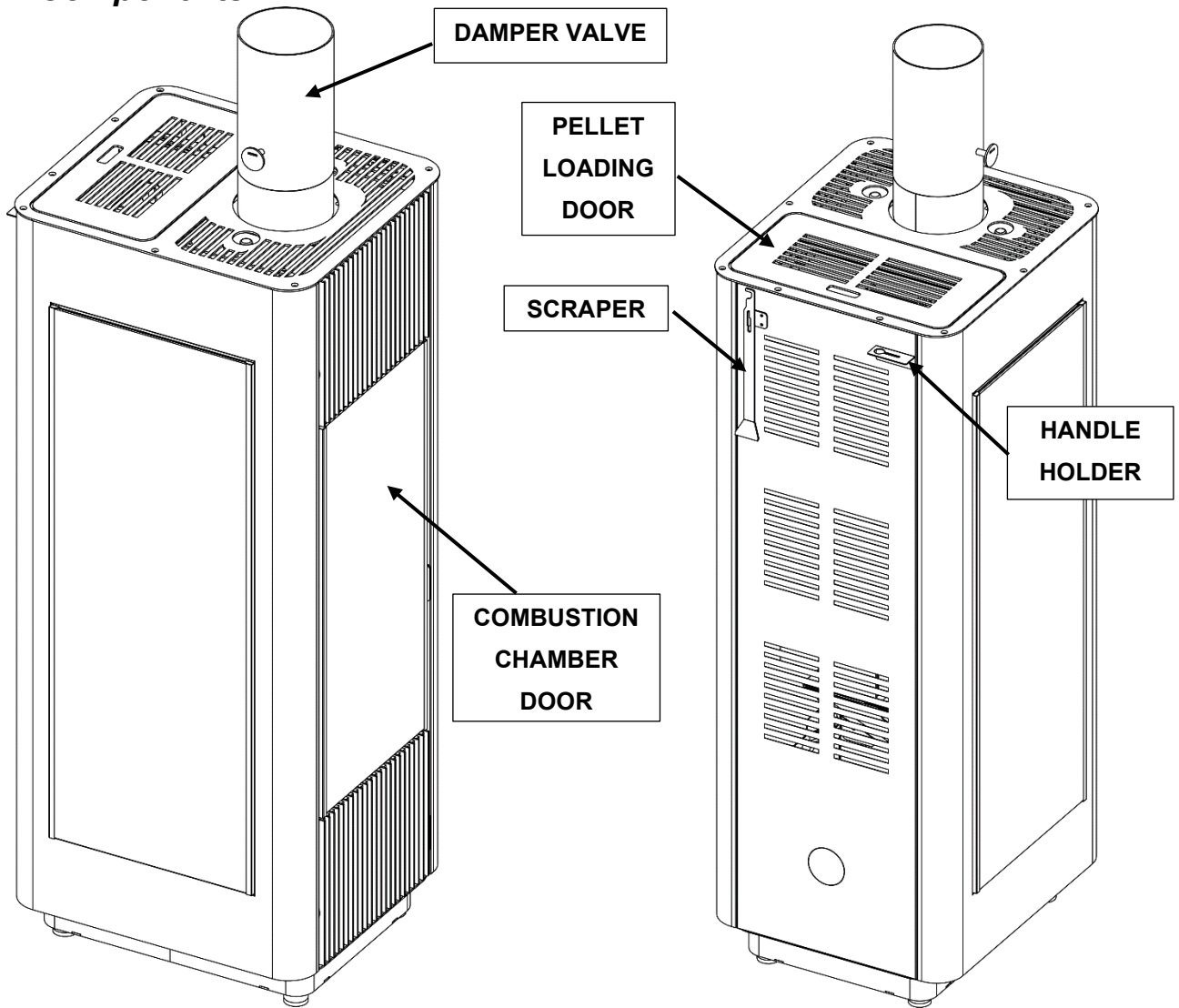

Fig.10

Fig.11

6.2 Filling up the tank

- Open the lid and move the pellet loading lever to the “Stop” position (fig. 12);
- Open the tank lid (fig. 13).

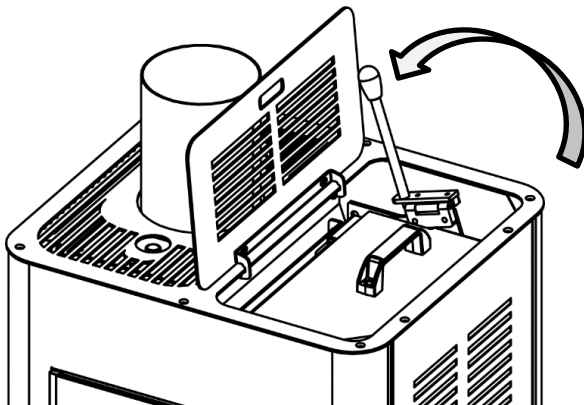

Fig. 12

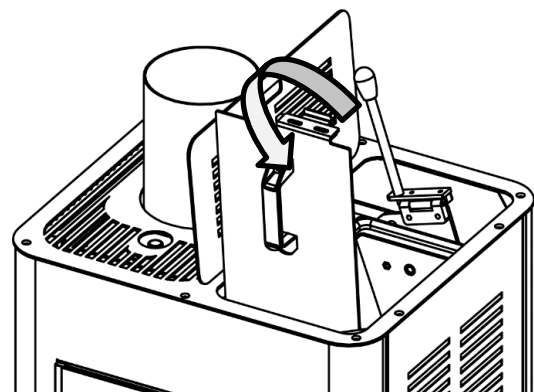

Fig. 13

You can load pellet also when the stove is working.

6.3 Ignition

Once the tank has been filled up, the stove is ready to be turned on. Put the lever in position "Go" and lower it to the rest position (*fig. 14*);

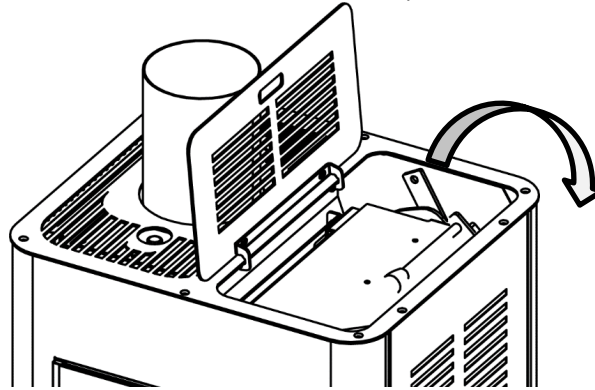

Fig. 14

The pellets will fall down until the brazier is full; now you can open the main door and position a solid or gel-like ignited on top of the pellets in the brazier and light it using a flame. Leave the door ajar for a couple of minutes or even longer (this depends on the room temperature and on the chimney flue). Close the door only when the flame reaches a minimum height of about 3 inches, so as to lick the holes located in the rear wall. Now the stove is turned on.

The fire door is equipped with a return spring that prevents accidental maximum opening.

ATTENTION: do not touch the door with bare hands while the stove is working.

CAUTION: *always clean the brazier prior to each ignition to avoid false starts, if there is little ash residue, clean it by means of the shaker (See paragraph 6.7); in case of hard-to-clean ash residue, take out the brazier and manually shake it.*

CAUTION: *always carry out this operation with the stove switched off and cooled down.*

CAUTION: RISK OF BURNS.

6.4 Combustion mode

Using the air adjustment lever positioned under the upper door, it is possible to vary the combustion air inlet and consequently the power of the stove.

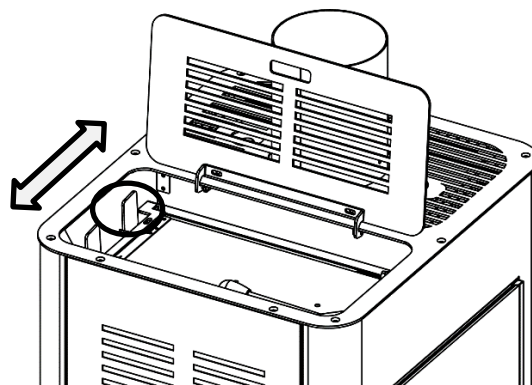

Fig. 15

ATTENTION: The minimum power of the stove depends on the draft of the chimney flue

6.5 Shutdown

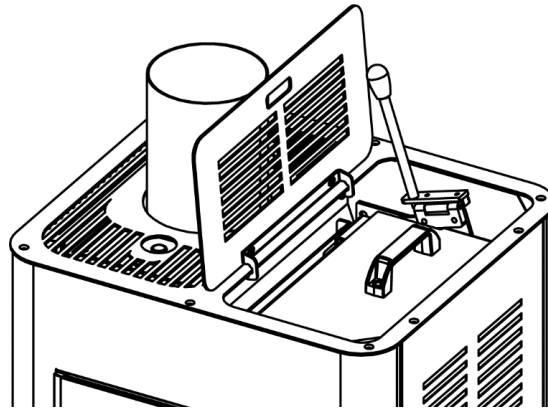

Fig. 16

By moving the lever in position “Stop” (fig. 16) the fall of pellet into the brazier will stop; combustion will continue for about 20 minutes, after which the stove will switch off.

To switch it back on, move the lever in position 2, place a solid or gel-like igniter on top of the pellets and light it up with a flame

CAUTION: to prevent burns wait at least 15 minutes before switching the stove back on.

CAUTION: RISK OF BURNS.

CAUTION: do not touch the brazier after switching off the stove.

6.6 Cleaning the exchanger

Hook the handle on the pin (fig. 17) and lift it up repeatedly causing the internal springs to shake and consequently the ash to fall into the combustion chamber; repeat this operation on the other pin

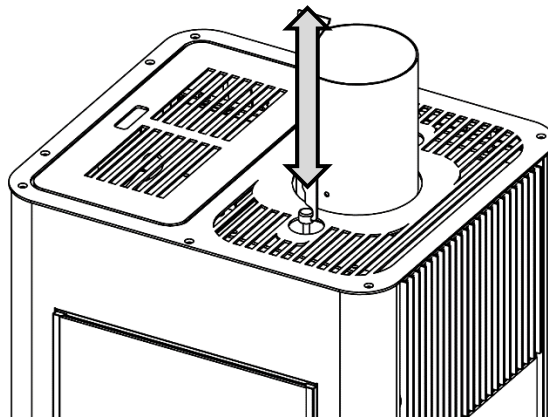

Fig. 17

The exchanger must be cleaned at least once a week; if the stove is used a lot (more than 8 hours a day), it is recommended to clean it every 3 days.

It is recommended to carry out this operation when the stove is cold to avoid getting burned; however, it can also be done while the stove is working, provided that utmost attention is paid to hot surfaces.

Do not leave the handle hooked up to the pin after cleaning the stove while it is working; put it away in the special compartment.

CAUTION RISK OF BURNS.

CAUTION: Do not touch the pin with bare hands while the stove is working to avoid getting burned

6.7 Cleaning the brazier with the shaker

To keep the flame always live and at maximum efficiency and avoid the formation of smoke, during operation it is necessary to clean the brazier using the specific shaker lever (*fig.18*), which drops the excess ash in the drawer (**no more than two or three blows**).

The frequency of this operation depends on the quality of the pellet used

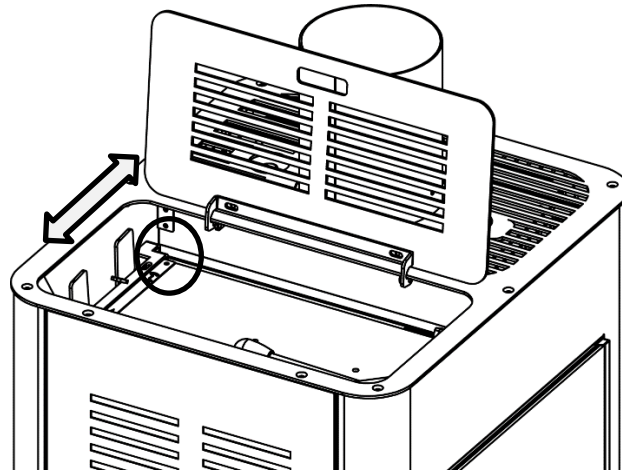

Fig. 18

CAUTION RISK OF BURNS.

7 WARNINGS AND MAINTENANCE



WARNING

The maintenance and care must be carried out only with cold device.

You should only use spare parts approved and supplied by Laminox Idro Srl please contact your specialized retailer if you require spare parts. You must not make any changes to the device!!!

The periodic maintenance, as indicated in this Installation and Operating Instruction, must be performed with the utmost care after reading the instructions, procedures and frequency described in this manual. Check the external air intake, by cleaning it, at least once a year. The flue must be regularly swept by the chimney sweeper. Let your chimney sweeper in charge of your area check the regular installation of the device, the connection to the flue and the aeration.

All maintenance operations (cleaning, replacements, etc.) should be carried out when the fire is out and the stove is cold. In addition, do not use any abrasive substances.

CAUTION: FAILURE TO CLEAN AFFECTS SAFETY

7.1 Opening the door

The door must remain closed during operation. The door should be opened only with the stove off and cooled down to perform maintenance and routine cleaning.

7.2 Ashes cleaning and disposal

Check the ash drawer every two days to see if it needs emptying

The ash collection compartment must be emptied regularly so as to impede combustion residue from arriving at the brazier support.

CAUTION: ashes keep embers on for a long time!!!



WARNING

Ashes should be placed in a metal container with a tight-fitting lid. The closed container of ashes should be placed on a non-combustible floor or on the ground, well away from all combustible materials, pending final disposal. If the ashes are disposed of by burial in soil or otherwise locally dispersed, they should be retained in the closed container until all cinders have thoroughly cooled.

7.3 Brazier cleaning

When the flame becomes a red colour or is weak accompanied by black smoke, it may mean that there are ash deposits or incrustations which are not allowing correct stove operation and which must be removed.

Every two days, remove the brazier by simply lifting it from its housing, then clean it of ash and any incrustations which could have formed, with particular attention to freeing clogged holes using a pointed tool.

This operation is necessary in particular the first few ignitions, especially when using different quality pellets. The timing of this operation is determined by the frequency of use and the choice of fuel. It is advisable to also check the brazier support, emptying it of any ashes.

CAUTION: before igniting the stove, check that the brazier is properly inserted and pushed back toward

7.4 Ash drawer cleaning

Check the ash drawer every two days to see if it needs emptying

The ash collection compartment must be emptied regularly so as to impede combustion residue from arriving at the brazier support.

CAUTION: ashes keep embers on for a long time!!!



WARNING

Ashes should be placed in a metal container with a tight-fitting lid. The closed container of ashes should be placed on a non-combustible floor or on the ground, well away from all combustible materials, pending final disposal. If the ashes are disposed of by burial in soil or otherwise locally dispersed, they should be retained in the closed container until all cinders have thoroughly cooled.

7.5 Combustion chamber cleaning

Clean the combustion chamber weekly, removing ashes accumulated in the chamber using a vacuum cleaner.

Note: Use a vacuum cleaner designed for the suction of ashes for this type of cleaning.

Once a week, open the front grille and pull the cleaner rod knob towards you at least 3 times.

7.6 Smoke chamber cleaning

Generally, clean the smoke chamber once a year (preferably at the beginning of the season) for best stove operation. The frequency of this operation depends on the type of pellet used and the frequency of use. Contact a Technical Assistance Centre for this type of cleaning.

7.7 Exhaust system cleaning

Until you are reasonably experienced regarding operating conditions, it is advisable to perform this service at least monthly. Remove the T-fitting cap and proceed with duct cleaning. If necessary, at least the first few times, request assistance from a qualified technician.

7.8 Cleaning metal and ceramic parts

Use a soft cloth moistened with water to clean metal stove parts.

Never clean metal or ceramic parts with alcohol, thinners, petrol, ketones or other degreasers.

Use of these substances frees the company from all liability. Discolouration of metal parts can be the result of improper use of the stove.

7.9 Pellet slide cleaning

With the scraper (Fig. 19), clean the pellet slide (Fig. 20) from any incrustations that can slow down or block the pellets' descent to the brazier.

It is recommended to do out this operation before each ignition in order to maintain the correct functioning.



Fig. 19

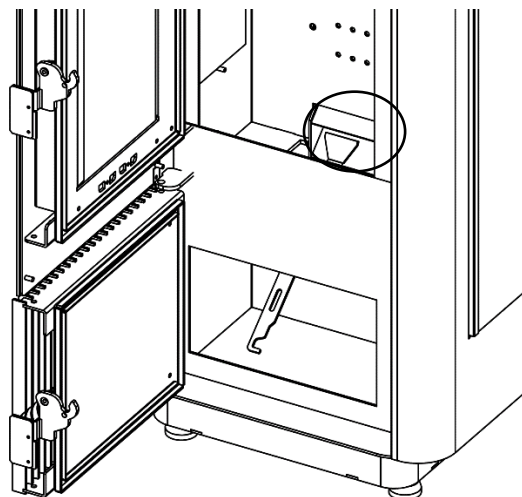

Fig. 20

7.10 Cleaning glass

Door glass must be clean (cold). Prevent corrosive substances from coming into contact with the paint on the stove as these can cause damage. Do not use any material that can scratch or damage the glass.



WARNING

The cleaning of glass must be carried out only and exclusively with cold device to avoid the explosion of the same glass.

For the cleaning, it is possible to use specific products or a wet newspaper paper ball passed in the ash to rub it. Do not use cloths, abrasive or chemically aggressive products by cleaning the hearth glass

7.11 Broken glass

The stove is equipped with 5 mm ceramic glass that is resistant to a thermal shock of 1350°F. This glass can break only due to a strong impact or misuse. Do not slam the door or hit the glass. In case of breakage, replace with an original replacement part only. (See paragraph 7.15)



WARNING

Break of glasses: ceramic-based glasses can resist up to a heat shock of 1350°F, therefore they are not affected by thermal shock issues. Their break can be caused by mechanic shocks, such as striking or slamming shut of the door. Therefore, their replacement is not included in the warranty

Do not operate this unit with broken glasses

Broken or damaged glass components shall be removed and reinstalled taking care about using proper gaskets, cushioning devices and other accessories, maintaining edge clearances (See paragraph 7.15)

Replace glass only with glass supplied from the manufacturer or distributor of this appliance

7.12 Stove inactivity

At the end of the season, perform the following operations:

- Remove all pellets from the tank and from the feed screw.
- Thoroughly clean the brazier, the support brazier, the combustion chamber and the ash drawer.
- Thoroughly clean the smoke exhaust system: contact a professional chimney sweep for this purpose.
- Clean all dust, spider webs, etc. from the area behind the panels of the inner cladding once a year.
- Clean fans thoroughly.

7.13 Routine and special maintenance

This pellet heater needs periodic inspection and repair for proper operation. It is against federal regulation to operate this pellet heater in a manner inconsistent with operating instructions in this manual

These operations should be programmed ANNUALLY with a Technical Assistance Centre and are necessary to ensure the maintenance of product efficiency and ensure safe operation.

- Thoroughly clean the combustion chamber and the heat exchanger.
- Smoke motor, dismantling and cleaning of the smoke exhaust duct, new silicone where required.
- Inspection and verification of gaskets, springs and replacement and application of the silicone where required
- Tank, emptying and cleaning.
- Check and replacement, if necessary, of components that are subject to wear: brazier, ash drawers, etc.

7.14 Routine maintenance performed by qualified technicians

Using wood as solid fuel, the generator requires annual routine maintenance, which must be performed by a qualified technician, using only original spare parts.

Failure to comply can jeopardise the safety of the appliance and make the warranty null and void.

Respecting the frequencies of cleaning reserved for the user described in the use and maintenance manual, the generator is guaranteed correct combustion over time, preventing any anomalies and/or malfunctioning that could require more interventions of the technician. Requests for routine maintenance are not contemplated in the product warranty.



WARNING

Routine maintenance must be performed at least once a year.

The annual routine maintenance must be performed by a qualified technician.

Using only original spare parts. Failure to comply can jeopardise the safety of the appliance and make the warranty null and void.

7.15 Spare parts replacement

Use only ceramic type glass

The gaskets guarantee the tightness of the product and its consequent good functioning. They must be controlled periodically. They must be replaced immediately if they are worn or damaged. These operations must be carried out by a qualified technician.

Ceramic Glass dimensions: 306 x239 mm (12" x 9,4"); Thickness 5 mm

Door tricovet gasket: *Diam.* 10 mm (0,39"); *L.* 1570 mm / (62")

For all other spare parts please contact your dealer using the list on the following pages as a reference.

Spare parts replacement operations must always be carried out by a qualified technician

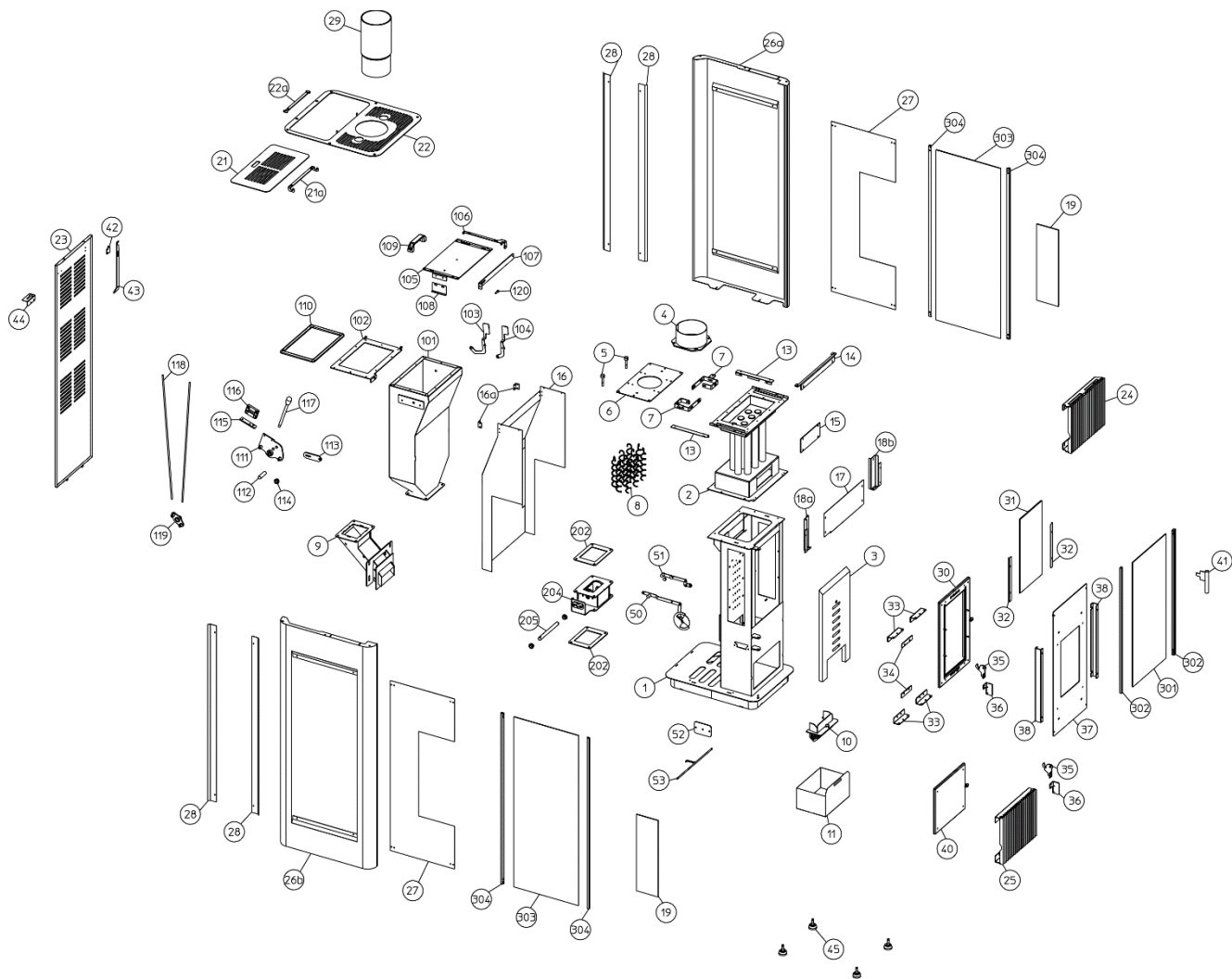

Ref. Drawing	Product code	Laminox description	N° Per Kit
1	PHX-STR	Structure	1
2	PHX-GRF	fumes circulation	1
3	PHX-VCC	Combustion chamber insulation	1
4	PHX-UF150	Smoke outlet	1
5	JSN9-PMT	Turbulators movement pin	2
6	PHX-TIT	Turbulators inspection cap	1
7	PHX-PT	Turbulator holder	2
8	PHX-TM	spring turbulator	8
9	PHX-SPI	pellet slide inox	1
10	HS13-BRA	Brazier	1
11	PHX-CC	ash drawer	1
13	PHX-AOL	lateral horizontal angle bracket	2
14	PHX-AOF	front horizontal angle bracket	1
15	PHX-TIG	fumes circulation inspection cap	1
16	PHX-DPS	tank heat shield diaphragm	1
16a	PXH-SQC	closure brackets heat buffer	1

17	PHX-TRF	finishing frontal plug	1
18a	PHX-ANSX	Left Angle bracket	1
18b	PHX-ANDX	Right angle bracket	1
19	PHX-VL-IN	Internal side glass	2
50	PHX-MOV-AR	air movement	1
51	PHX-MOV-SC	shaker movement	1
52	PHX-TSC	shaker plug	1
53	PHX-SCT	shaker burner	1
43	PHX-RAS	Scraper water slide pellet	1
--	STP-VF-150	Throttle	1
30	PHX-PRT	fire door (without glass and handle)	1
31	PHX-VTR-IN	Internal door glass	1
32	PHX-SRV	Glass holder brackets	2
33	PHX-SPA	front plate door support	4
34	PHX-TAS	explosion-proof plug door	2
35	PHX-MIN	interior handle	2
36	PHX-MEX	external handle	2
	PHX-PAS	front door plate	1
38	PHX-ANR	reinforcement angle bracket	2
40	PHX-PRC	ash door	1
41	STP-MCE	removable handle	1
301	PHX-VTF-EX	External front glass	1
302	PHX-GPV	glass guide	2
--	STP-GS10	Door seal	1
--	STP-GA2	Adhesive glass seal	1
114	STP-BRO	Bushing	4
--	PHX-SAS	assembled tank	1
101	PHX-SRB	tank main body	1
102	PHX-CS	tank frame	1
103	PHX-LRA	air regulation lever	1
104	PHX-LSC	shaker lever	1
105	PHX-CSP	pellet tank cover	1
106	PHX-CCS	hinge tank cover	1
107	PHX-ABC	Tank locking rod	1
108	PHX-BAP	Tank opening lock	1
109	PHX-MCS	handle cover tank	1
110	STP-GAS	Pellet tank adhesive seal	1
111	PHX-SLC	support locking lever	1

112	PHX-AMC	shaft opening mechanism	1
113	PHX-BAS	Safety rod lock	1
115	PHX-SPC	hinge support	1
116	PHX-CRN	snap hinge	1
117	PHX-LCV	closing lever pellet valve	1
118	PHX-AMB	Balance movement rod	2
119	PHX-FAB	fulcrum locking rod	1
21	PHX-CP	Top cover	1
21a	PHX-CM	mobile hinge	1
22	PHX-TS	Top	1
22a	PHX-CF	fixed hinge	1
23	PHX-DP	back diaphragm	1
24	PHX-GS	top grid	1
25	PHX-GI	lower grid	1
26a	PHX-FDX	right side panel	1
26b	PHX-FSX	left side panel	1
27	PHX-SVL	side glass support	2
28	PHX-FRL	Side finishing band	4
303	PHX-VL-EX	External side glass	2
304	PHX-GPV-L	side glass guide	4
29	PHX-DAM	Damper valve	1
45	STP-PIE	Adjustable foot	4
202	LMX-GA2	silicone seal	2
204	JSN9-VPA	assembled pellet valve	1
205	PHX-BR	rotation shaft	1

8 WARRANTY

8.1 Certificate of warranty

The purchaser is invited to:

- Examine the instructions for the installation, use and maintenance of the stove.
- Examine the conditions of warranty shown below and the "*Limited Warranty certificate*" included in this manual

8.2 Condition of warranty

The limited warranty covers defects of manufacturing materials, on condition that the product has not been broken due to an incorrect use, carelessness, wrong connections or errors of installation.

The following are not covered by guarantee:

- *vermiculite (Firex 600)*;
- *the glass of the door*;
- *the fibre gaskets*;
- *the painting*;
- *the fire pot*;
- *the cast majolica*;
- *any damage caused by inappropriate installation and/or handling of the stove and/or shortcomings by the consumer*

. The use of poor-quality pellets or of any other material could damage components of the stove causing the termination of their guarantee and the annexed responsibility of the manufacturer.

The pellets which meet the requisites listed in the chapter on them should be used.

All damage caused by transport are not acknowledged, therefore please carefully check the goods on receipt, immediately advising the dealer of any damage.

All the manufacturer's guarantees are shown here and no complaint may be made to the manufacturer according to any other guarantee, report or request.

For warranty claims and instructions for return shipments please refer to your local dealer.

8.3 Information and problems

For any information or problems, please contact your dealer or service centre, the only people who can meet any request you may have end, if necessary, who can intervene directly

Limited Warranty certificate

Subject matter

Laminox Srl, provides a warranty on all product marketed under the *Laminox Idro* brand and installed professionally by authorized personnel within the North American territory: subject to limitations set out below mentioned.

The manufacturer's warranty allows customers to request the free of charge replacement or repair of product parts solely, in case where non-conformance due to manufacturing defects is detected and acknowledged by trained personnel.

During the warranty period, Laminox undertakes to correct defects caused by manufacturing defects, at no cost to the Customer, through its network of customer services, which the Customer can contact by contacting the dealer. In any case, Laminox points out that the appliance must be installed in an easily accessible place in accordance with current legislation. Otherwise, the costs necessary to intervene will be entirely borne by the Customer.

Warranty period

Laminox S.r.l. guarantees its products for 24 months (two years) from the date of purchase by the end customer (hereinafter Customer), proven by a valid fiscal document issued by the authorized reseller (receipt, invoice) that identifies the product purchased and the date of purchase and/or delivery of the same.

Validity

This warranty is valid exclusively for products installed in North America

The warranty includes the free repair or replacement of the component parts of the appliance which are defective at the origin due to manufacturing defects, with the exception of the hypotheses listed in the "Exclusions" paragraph.

The right to the guarantee will be proven by this original certificate, from which the model, the serial number of the product, the date of purchase and the company name of the retailer can be deduced and by a document valid for tax purposes, issued by the retailer at the time of purchase.

The warranty is recognized as valid provided that:

- 1) The appliance has been installed by qualified personnel in compliance with the regulations in force on the matter, respecting the instructions contained in this use and maintenance instructions;
- 2) The appliance is used according to the methods described in this use and maintenance instructions;
- 3) The lack of conformity is reported;
- 4) This certificate is accompanied by a purchase document certifying payment for the goods and showing the retailer's company name, model and purchase price.

Exclusions

The warranty is not recognized in the following cases:

- 1) The terms of validity have not been respected;
- 2) The installation has not been carried out in compliance with the regulations in force on the matter, respecting the prescriptions contained in this use and maintenance instructions. Installations that do not comply with current standards will void the product warranty, as will improper use and lack of maintenance as foreseen by the manufacturer;
- 3) It is found by the customer service that conditions external to the functioning of the product have caused it;
- 4) For interventions aimed at explaining the functioning of the product, periodic checks and maintenance and all that, at the time of sale, had been brought to the attention of the Customer or that the latter could not reasonably ignore;
- 5) Negligence in maintenance, carelessness, tampering, accidental breakage, damage in transport,

- incorrect handling, as well as improper use and maintenance by the Customer is found;
- 6) Combustion of materials that do not comply with the types indicated in the use and maintenance manual;
 - 7) Damage caused to the equipment by atmospheric and natural events (such as lightning, floods, fires, earthquakes) or by acts of vandalism;
 - 8) Operational alterations due to climatic, atmospheric, environmental or other conditions;
 - 9) Acknowledgment by the customer service of the presence of non-compliant electrical and/or hydraulic systems or fume ducts;
 - 10) For which an insufficient or non-compliant flow rate of the electrical systems is found;
 - 11) No defect has been found, as reported by the Customer, or for generic operating problems deriving from a wrong impression by the user (problems with noise, heating, timer programming, etc.);
 - 12) Interventions for calibration or adjustment of the product in relation to the type of fuel used or the particularities of the installation;
 - 13) Transport damage not dependent on the manufacturer. In this regard, it is recommended to carefully check the material upon receipt, immediately notifying the retailer and reporting the annotation both in the transport document and on the carrier's copy.

Laminox S.r.l. declines all responsibility for any damage that may directly or indirectly be caused to people, things or animals as a result of failure to observe all the instructions indicated in the specific instruction booklet and concerning installation, use, operation and maintenance of the appliance.

For the period of inefficiency and for direct or indirect damage due to or dependence on the product, no compensation is recognized.

The interventions carried out for the replacement of components subject to wear and/or removable are also excluded from the guarantee, unless their breakage and/or their malfunctioning are not attributable to original defects: - *vermiculite (Firex 600)*;

- *the glass of the door*;

- *the fibre gaskets*;

- *the painting*;

- *the fire pot*;

- *the cast majolica*;

- *any damage caused by inappropriate installation and/or handling of the stove and/or shortcomings by the consumer*

First ignition test (for a fee)

This product requires first start-up testing by an authorized customer service which will regulate the operating parameters and provide all the information for correct use.

It is essential to have the product function tested before completing any wall finishes (smoke duct covers, coverings, painting, etc.). The company assumes no responsibility for any damage and consequent costs of restoring the finishes mentioned even if they were to result from the replacement or repair of non-functioning parts.

Downtime period

In case of product malfunction, the customer service shall arrange to repair the product as quickly as possible, without prejudice to the fact that no compensation will be granted for the downtime period

Important: The assistance interventions must be carried out by the customer service, in total safety according to the current provisions of the law on the subject. The means necessary for the safe execution of the assignment (scaffolding, handling equipment, etc.) will be procured by the Client and the consequent expenses will be borne exclusively by him. If the technician recognizes the defect as prescribed by the laws in force regarding safety. He may legitimately refuse to carry out the requested intervention. by charging the Client the cost of the exit.

1. The technician has the task of restoring the conformity of the product on the basis of the provisions of the guarantee conditions;
2. The technician is the only person competent to establish the correct functionality of the product and evaluate its possible irreparability on site. In this second hypothesis, the product must be sent, with suitable packaging, to the Laminox company for repair and general testing with costs to be borne by the customer. In cases of irreparability, the replacement can be carried out only following the written consent of the manufacturer, leaving unchanged the expiry date and the terms of guarantee acquired at the time of purchase of the product;
3. The technician will process requests for intervention for repairs under warranty promptly, compatibly with organizational requirements. In any case, however, the manufacturer cannot be held responsible for any inconvenience caused by any delays in carrying out the intervention.

Once the warranty period stipulated in the contract has expired, the costs for any restoration work must be borne by the Customer. In this case, the Customer can contact the TAC network, from which he can obtain, in addition to a high professional service, original, tested and guaranteed spare parts.1.

REFERENCES STANDARDS:

ASTM E1509
UL 1482
ULC S627
UL 181
UL 641
ULC S609
NFDA (Fire) 211

Laminox S.r.l. reserves the right to change the characteristics and data reported in the following document at any time and without warning in order to improve their products. This manual, therefore, cannot be considered as a contract with third parties.

Updated manuals and drawings are available at website www.laminox.com.

PLEASE CONTACT YOUR DEALER FOR ANY SERVICE OR QUESTION

Appliance information:

SERIAL NUMBER _____

DATE PURCHASED _____

DATE INSTALLED _____



Laminox S.r.l. Hydro Division
Zona Industriale Callarella, 261/263 – 62028 SARNANO (MC) Italy Tel.
+39 0733.657.622 – Fax +39 0733.657.494
www.laminox.com e-mail: idro@laminox.com



USE AND MAINTENANCE INSTRUCTIONS

PELLET STOVE WITH NATURAL DRAFT

Lydia Natural

SAVE THIS INSTRUCTIONS

WARNING: Please read this entire manual before installation and use of this pellet fuel-burning room heater.

Failure to follow these instructions could result in property damage, bodily injury or even death

CAUTION: Contact local building or fire official about restrictions and installation inspection requirement in your area

Dear Customer, thank you for choosing one of our products, which is a result of technological expertise and our continuous quest for superior products in terms of safety, reliability and performance. This manual contains all the information and helpful tips for using your product with maximum safety and efficiency.

IMPORTANT INFORMATION

This manual has been prepared by the manufacturer and is an integral and essential part of the product. In the event of sale or transfer of the product, always ensure the presence of the manual as the information it contains is addressed to the purchaser and to all those various people involved in the installation, use and maintenance of the product. Carefully read the instructions and information contained in this manual before installation, operation and maintenance of the product. The instructions contained in this instruction manual guarantee the safety of persons and property and ensure efficient operation and a longer service life. The manufacturer declines all responsibility for damage caused by failure to observe instructions regarding installation, use and maintenance listed in the instruction manual, for unauthorised modifications or non-original replacement parts. Product installation and use must be carried out in accordance with the manufacturer's instructions and in compliance with European, national and local regulations. Installation, electrical connection, functional testing, maintenance and repairs are operations that must be performed by qualified and licensed personnel who must have appropriate knowledge of the product. Product installation must not be carried out close to walls made of wood or combustible material. For proper installation, you must observe the following "Safety distances" section. Verify the exact flatness of the floor where you will install the product. When handling the steel parts of the cladding, use clean cotton gloves to avoid leaving difficult to remove fingerprints for the first cleaning. Stove installation must be performed by at least two people. Connect the stove to the mains only after proper professional connection to the chimney flue. The power cable plug must remain accessible after installation of the stove. Only operate the stove with regulation wood pellets (refer to the "FUEL" chapter). Never use liquid fuels to operate the pellet stove or to stoke the embers present. Provide adequate ventilation in the installation area throughout the year. In the presence of operation failures, fuel supply will be interrupted. Re-start the unit after removing the cause of the failure. Discontinue use of the product in the event of failure or malfunction. Do not remove the safety guard located in the pellet tank. Any accumulated unburned pellets in the burner as a result of repeated "failed ignitions must be removed prior to ignition." Pellet stove operation can cause very hot heating of the handles, the chimney flue and glass surfaces. Only touch these parts during operation when wearing protective clothing or with adequate aids. Because of the creation of heat on the glass, make sure that no persons unfamiliar with stove operation stand in the installation area. Inform children of the precautions to be observed during product operation and of possible dangers. In the event of problems or misunderstanding of the instruction manual, contact your dealer. Placing objects which cannot withstand heat on the stove or within the minimum required safety range is prohibited. Do not open the door during operation or operate the stove with its glass broken. For product terms, limitations and exclusions, please refer to the warranty included with the product. In order to pursue a policy of constant product development and renewal, the manufacturer may make changes to it as deems appropriate without notice. This document is the property of the manufacturer and cannot be disclosed in whole or in part to any third party without the written consent of the company, which reserves all rights to the rigor of the law.

1	GENERAL STANDARDS	4
1.1	Fireplace or Chimney flue	4
1.2	Chimney cap	5
1.3	External air intake vent	6
1.4	Connection to the chimney flue	6
1.5	Preventing house fires	6
2	SPECIFICATIONS AND TECHNICAL DATA	7
2.1	Specifications	7
2.2	Compliance status	7
2.3	Technical data	7
2.4	Product identification data	7
3	FUEL	8
3.1	General notes	8
4	INSTALLATION	9
4.1	General notes	9
4.2	Minimum safety distances	10
4.3	Flooring protection	12
4.4	Minimum distances for positioning air intake vents	12
4.5	Vent exhaust duct	12
4.6	Using an external fume duct	14
5	ASSEMBLY	14
5.1	General notes	14
5.2	Unpacking	14
6	USE	15
6.1	Components	16
6.2	Filling up the tank	16
6.3	Ignition	17
6.4	Combustion mode	17
6.5	Shutdown	18
6.6	Cleaning the exchanger	18
6.7	Cleaning the brazier with the shaker	19
7	WARNINGS AND MAINTENANCE	20
7.1	Opening the door	20
7.2	Ashes cleaning and disposal	20
7.3	Brazier cleaning	20
7.4	Ash drawer cleaning	21
7.5	Combustion chamber cleaning	21
7.6	Smoke chamber cleaning	21
7.7	Exhaust system cleaning	21
7.8	Cleaning metal and ceramic parts	21
7.9	Pellet slide cleaning	21
7.10	Cleaning glass	22
7.11	Broken glass	22
7.12	Stove inactivity	22
7.13	Routine and special maintenance	22
7.14	Routine maintenance performed by qualified technicians	23
7.15	Spare parts replacement	23
8	WARRANTY	27
8.1	Certificate of warranty	27
8.2	Condition of warranty	27
8.3	Information and problems	27

1 GENERAL STANDARDS

1.1 Fireplace or Chimney flue

Each device must have a vertical duct, called a chimney flue, for outside release of combustion fumes produced by a natural draft.

The chimney flue must meet the following requirements:

- It should not be connected to any other fireplace, stove, boiler, or hood of any kind (Fig. 1).
- It must be properly spaced from combustible or flammable materials through an air gap or suitable insulating material.
- The internal section must be uniform, preferably circular: the square or rectangular sections must have rounded corners, curves must be regular and seamless, deviations from the axis no greater than 45° (Fig-2).
- Each device must have its own chimney flue with a section equal to or greater than the diameter of the fume exhaust pipe of the stove and a height no less than the one stated (see table 2).
- Never use two stoves, a fireplace and a stove, a stove and a wood stove, etc. in the same room since the draft of one could damage the draft of the other. In addition, collective ventilation ducts that can cause a vacuum in the installation environment are not permitted, even if installed in adjacent rooms and communicating with the installation room.
- Creating fixed or mobile apertures on the chimney flue to connect equipment other than auxiliary devices is prohibited.
- Passing other air supply channels and piping for utilities through the chimney flue, however large, is prohibited.
- The chimney flue should be equipped with a collection chamber for solid materials and any condensate, located below the mouth of the flue, so as to be easily opened and inspected from an airtight door.
- Whenever using parallel output chimneys, it is advisable to raise a bracing element. (Fig.3)

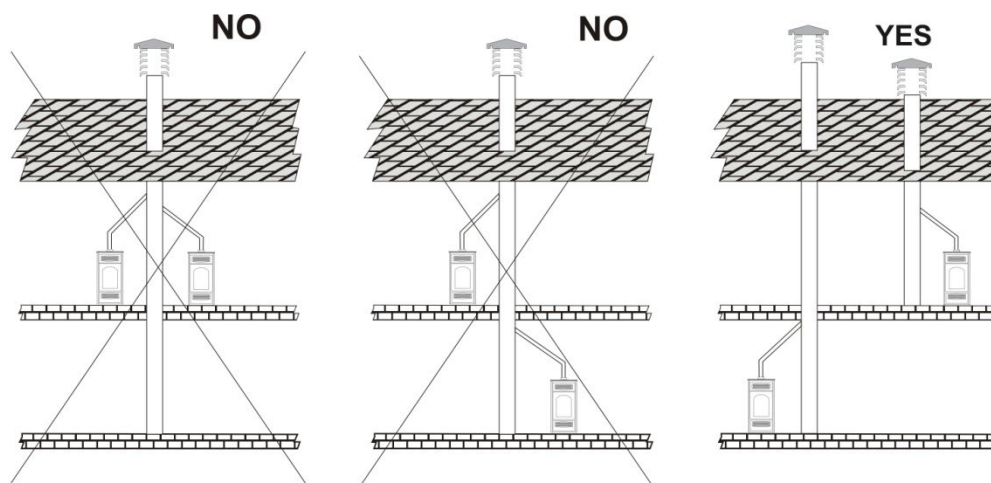

Fig 1

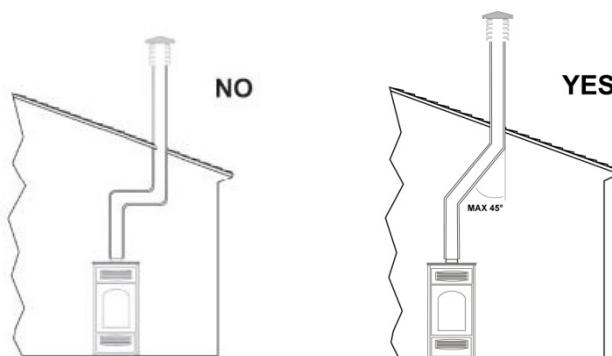

Fig 2

1.2 Chimney cap

The top of the chimney flue must be equipped with a device, called a chimney cap, which facilitates dispersion into the atmosphere of combustion products.

The chimney cap must meet the following requirements:

- Its internal section and shape must be equivalent to that of the chimney flue.
- Have a useful outlet section no less than double that of the chimney flue.
- Chimney caps that emerge from the roof or which remain in contact with the outside (for example in the case of an open loft), must be covered with brick elements and well isolated. It must be constructed so as to prevent penetration into the flue of rain, snow, or foreign bodies and so that, in the event of winds in any direction and at any angle, it assures the discharge of combustion products (windproof chimney cap).
- The chimney cap must be positioned so as to guarantee an adequate dispersion and dilution of combustion products and, in any case, outside the zone of reflux. This zone can be different sizes and shapes depending on the angle of slope of the roof, so it is necessary to adopt the minimum heights shown in Fig.3 and Fig.4.
- The chimney cap must be of windproof and exceed the height of the ridge, Fig.3 and Fig.4.
- Any buildings or other obstacles that exceed the height of the chimney cap must not be close to the chimney cap itself (Fig.3).

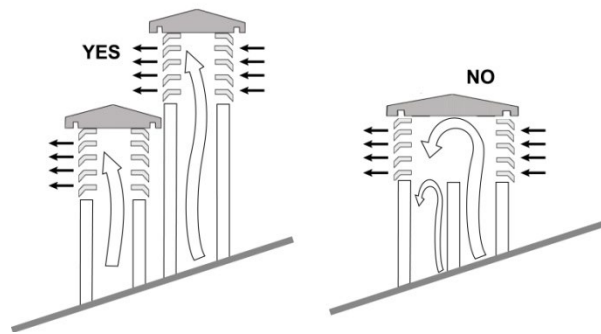

Fig.3

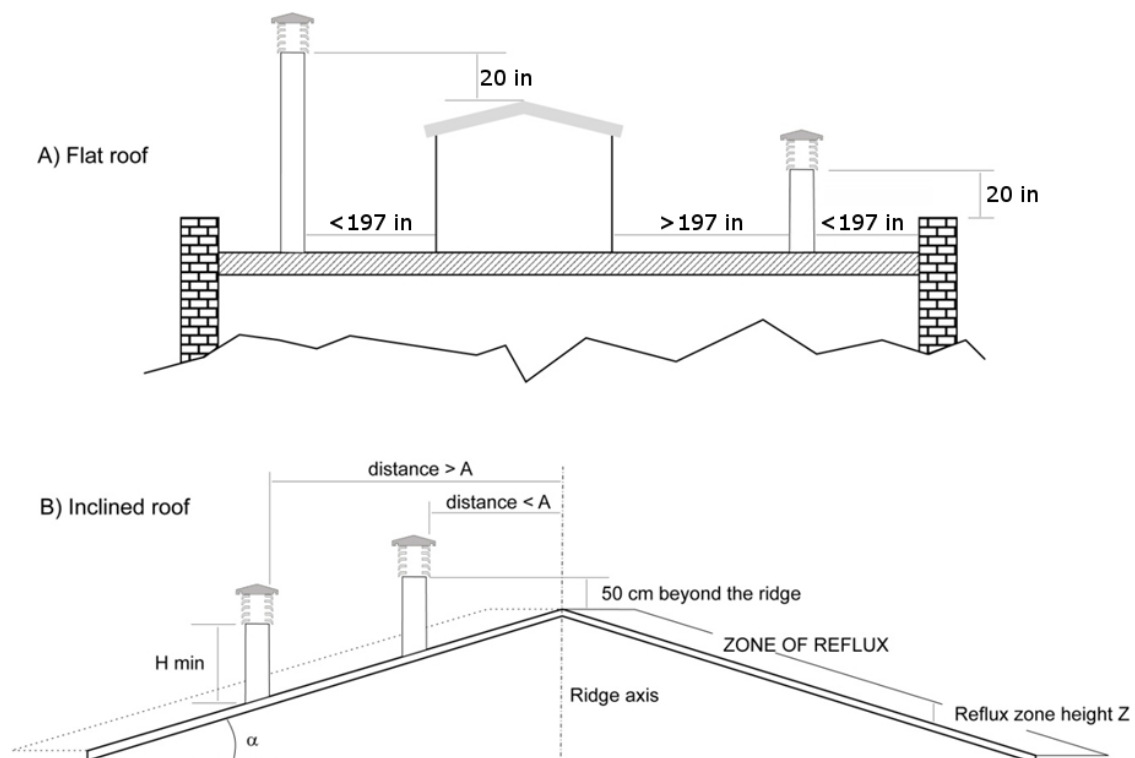

Fig.4

Roof pitch ? [°]	Horizontal width of the zone of reflux from the axis of the ridge A	Minimum height of the outlet from the roof	Height of the reflux zone Z
15	6 feet (1.85m)	3 feet (1.00m)	1 foot (0.50m)
30	5 feet (1.50m)	4 feet (1.30m)	2 feet (0.80m)
45	4 feet (1.30m)	6 feet (2.00m)	5 feet (1.50m)
60	4 feet (1.20m)	8 feet (2.60m)	7 feet (2.10m)

Table 2

1.3 External air intake vent

- The stove must have the air necessary to ensure smooth combustion operation and good environmental well-being.
- Make sure that the room where the stove is installed offers sufficient ventilation and install an air supply duct from the outside with the recommended minimum section of 15 in².
- The air intake vent must communicate directly with the installation room of the stove, positioned so as to prevent it from being blocked and protected with a permanent non-lockable grid or other suitable protection provided that it does not reduce the minimum section.
- Air flow can also be obtained from a room adjacent to the installation room, provided that this flow can be carried out freely through permanent, non-closable openings communicating with the outside.
- With respect to the installation room, the adjacent room should not be put under vacuum with respect to the external environment as a result of a reverse draft caused by the presence in this space of another utility device or suction device. The room adjacent to the permanent openings must meet the requirements set out in the paragraphs above. The adjacent room cannot be used as a garage, for storage of combustible material or for activities involving a risk of fire.

1.4 Connection to the chimney flue

(See paragraph 4.5)

1.5 Preventing house fires

Installation and use of the stove must be in accordance with the manufacturer's instructions and with local habitability regulations.

CAUTION: when a fume exhaust pipe passes through a wall or ceiling, particular installation methods must be applied (protection, thermal insulation, distances from heat sensitive materials, etc.).

- The fireplace connecting tube must never pass through a combustible surface.
- Do not connect this unit to a chimney flue already being used by another device.
- It is also advisable to maintain all combustible elements or flammable material such as beams, wooden furniture, curtains, flammable liquids, etc. outside the radiation area of the furnace and at a distance of at least 3 feet from the heating block.
- In the event that the surrounding space has coverings in combustible or heat-sensitive material, a protective membrane made of non-combustible insulating material must be interposed. If the flooring is made of combustible material, a non-combustible protective material must be provided at the mouth of the furnace.
- For further information, refer to local requirements.

2 SPECIFICATIONS AND TECHNICAL DATA

2.1 Specifications

Stoves and pellet stoves are devices built to work with good quality wood pellets only (see par. 3 fuel).

2.2 Compliance status

The heaters described in this manual meet the 2020 U.S. Environmental Protection Agency's wood pellet emission limit for wood heaters sold after May 15th 2015.

	Emission Rate (g/hr)	Heating Efficiency (% Overall) *	1st hour Emission Rate (g/hr)	CO emission (gr/h)
Lydia Natural	1,3	79	4,9	4,8

* Efficiency Calculated Per CSA B415.1

2.3 Technical data

Model of type	Lydia Natural
Pellet hourly consumption (min/max)	2,2-4,4 lb/h
Efficiency	79%
Hopper capacity	33 lb
Smoke outlet ø	5.9 in
Weight	330 lb
Dimension (DxWxH)	19,2x21,4x53 in

*Pellet size may affect actual rate of fuel feed and burn times. Fuel feed rates may vary by as much as 20%. Follow Manufacturer instructions and Use PFI certified pellet fuels to maximize efficiency.

2.4 Product identification data

The technical label shows device data and performance. Tampering with, removing or lack of a technical label makes installation and maintenance operations difficult, due to the lack of product identification. In the event of damage, request a duplicate from our service centre. Given the importance of the data label, we recommend installing the stove at a distance at which it is always visible.

3 FUEL

3.1 General notes

The pellet stove is designed to burn wood pellets only.

Wood pellets are a fuel obtained from the pressing of sawdust timber, extracted from the processing and transformation residues of dried wood material. The compactness of the product over time is guaranteed by a natural origin substance contained in the wood: lignin. The typical small cylinder form is obtained by extrusion.

Various types of pellets with quality and characteristics that vary depending on the processing and type of wood species used are available on the market.

CAUTION: Always use certified quality wood pellets: i.e. DIN, DIN PLUS, ÖM 7135, Pellet Gold, Catas etc. The company does not guarantee proper stove functioning with the use of low-quality pellets.

Stoves and heating stoves are tested and programmed to ensure good performance and perfect quality operation with specific characteristic pellets:

components:	wood
length:	< 30 mm
diameter:	6-6.5 mm
lower calorific value:	≥ 4.8 kWh/kg (≥7500 BTU/lb)
humidity rate:	< 8 %
residual ash:	< 0.5 %

GOOD QUALITY pellets are smooth, shiny, slightly dusty and with regular length. LOW QUALITY pellets are of varied lengths, dusty with vertical and horizontal splits.

Since pellet characteristics and quality greatly influence the autonomy, efficiency and proper operation of the stove, we recommend:

AVOID using pellets with dimensions different from that described by the manufacturer.

AVOID using low quality pellets or pellets containing dispersed sawdust powder, resins or chemicals, additives or adhesives.

AVOID using moist pellets.

The use of unsuitable pellets causes:

- clogging of the brazier and fume discharge ducts
- increased consumption of fuel
- decreased efficiency
- no guarantee of normal stove operation
- dirtying of glass
- production of unburned granules and heavy ash

The presence of moisture in pellets increases the volume of the capsules and crumbles, causing

- feeding system malfunctions
- poor combustion

Pellets should be stored in a dry and sheltered place. Particular attention should be given to the handling of the bags to prevent their crushing, resulting in the formation of sawdust.

Stove operation parameters may have to be altered when using quality pellets with dimensional and calorific characteristics different from those indicated. Contact an authorised service centre if necessary.

The use of poor-quality pellets not in accordance with manufacturer's instructions not only damage the stove and compromise performance but may result in forfeiture of the warranty and company liability.

Follow Manufacturer instructions and Use PFI certified pellet fuels to maximize efficiency.

4 INSTALLATION

4.1 General notes

WARNING: DO NOT INSTALL IN SLEEPING ROOM

The stove requires a UL listed pellet vent. So the venting system shall be approved for pellet stoves by a certified testing Laboratory

4.1.1 Installation in the presence of several appliances.

The presence of several appliances powered with different fuels, as well as hoods with or without extractor, must be evaluated during preventive checks and during the start up test in order to detect any variation compared to the design conditions or any aspect that cannot be detected during the design phase. The room must be well-ventilated according to the instructions of every single device. The external air intake vent must meet the requirements of paragraphs 1.3 and 4.4

The stove must not be used simultaneously with other generators that collect air from the environment even if installed in adjoining or communicating rooms

4.1.2 Suitability of the installation rooms

- Installing the device inside garage, store for combustible materials or rooms at risk of fire is prohibited.
- If the flooring is made of wood, provide a floor protection surface in compliance with current national standards
- Outdoor installation is prohibited, as well as exposure to atmospheric agents or humid areas.
- Locating the stove in a room with an explosive atmosphere is prohibited

4.1.3 Fume discharge system

Every device must be connected to a fume discharge system, which ensures dispersion of combustion products into the atmosphere.

The combustion products must be discharged from the roofs. Direct wall discharge or towards closed spaces, even in open air, is prohibited.

The components must be made of material with A1 fire reaction class. In particular, the use of metal extendible and flexible hoses is prohibited.

CAUTION: ensure that the plug for electrical connection remains accessible after the stove installation.

4.2 Minimum safety distances

The following figures show the minimum safety distances, which must always be guaranteed.

4.2.1 Corner installation

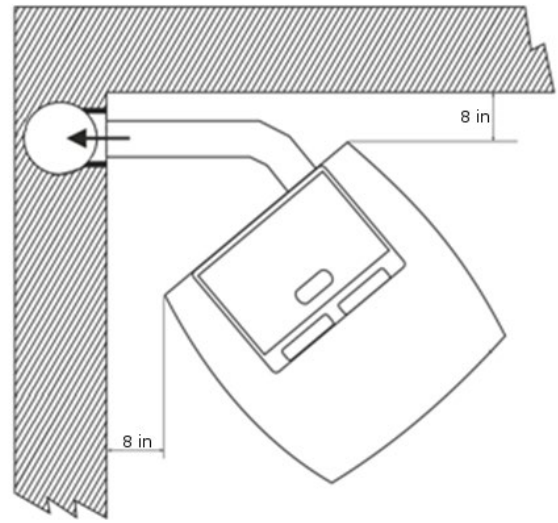

4.2.2 Wall installation

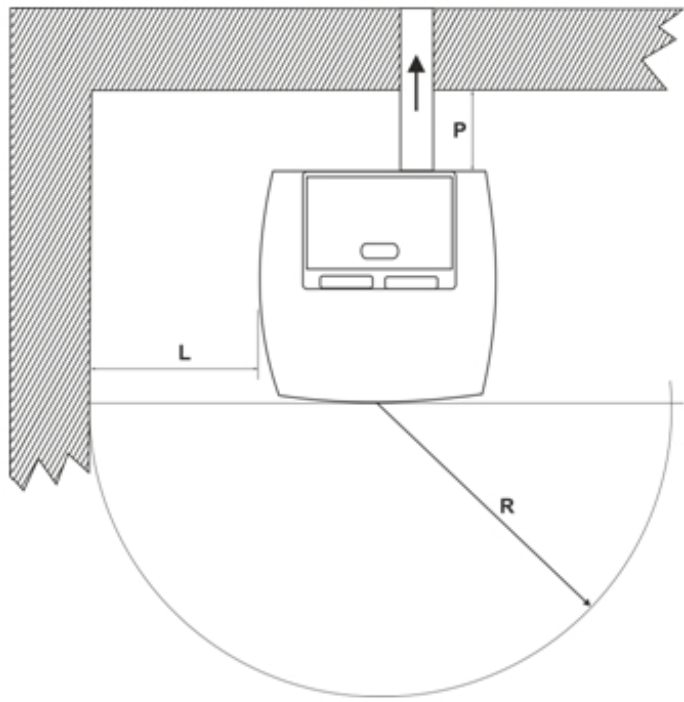

Safety distances from flammable material:

- Minimum distance in air from the flammable rear wall **P = 8 in**
- Minimum distance in air from the flammable side wall **L = 8 in**
- Frontal distance from flammable material **R = 40 in**

4.2.3 Distance from flammable ceilings and false ceilings

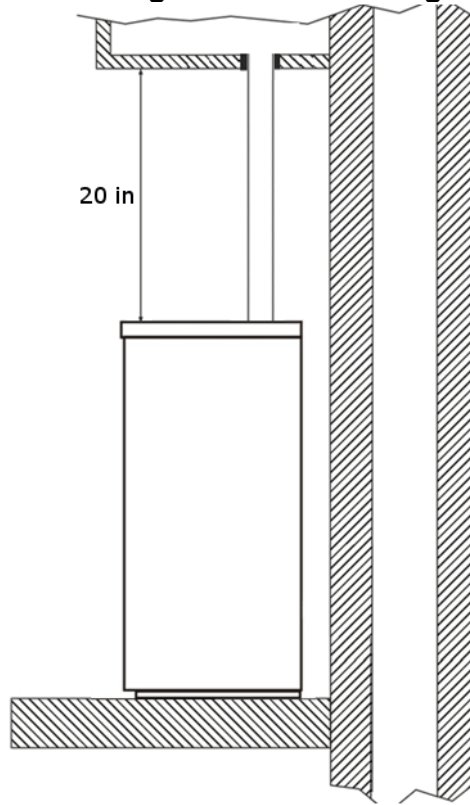

4.2.4 Distance of fume exhaust system from flammable walls

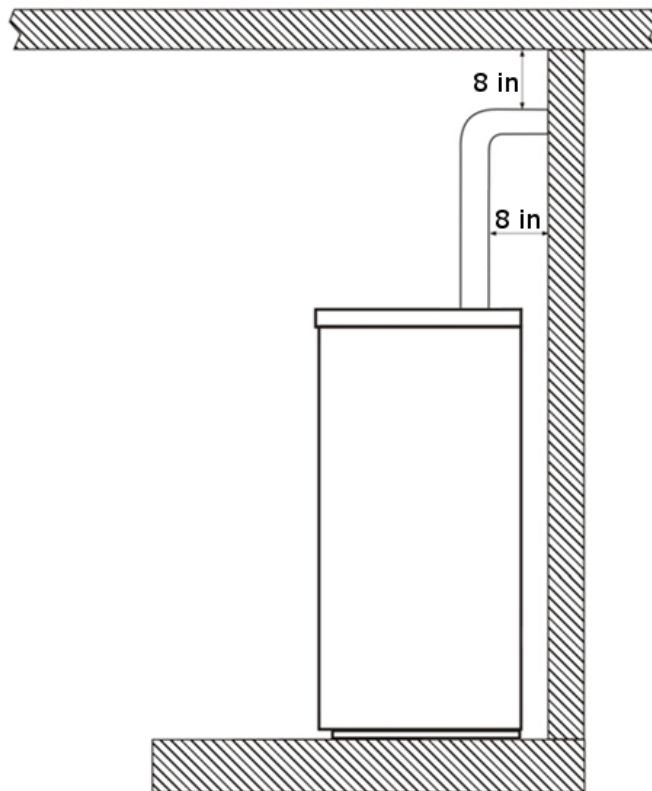

4.3 Flooring protection

In the event of valuable flooring or flooring that is sensitive to heat, moisture or is flammable, a floor protection must be used (i.e. sheet steel, marble or tile slabs). Whichever type of protection selected, it must protrude at least 12 in from the front, at least 6 in from the sides of the stove, must withstand the weight of the stove and have a thickness of at least 2 mm (Fig. 5 and 6).

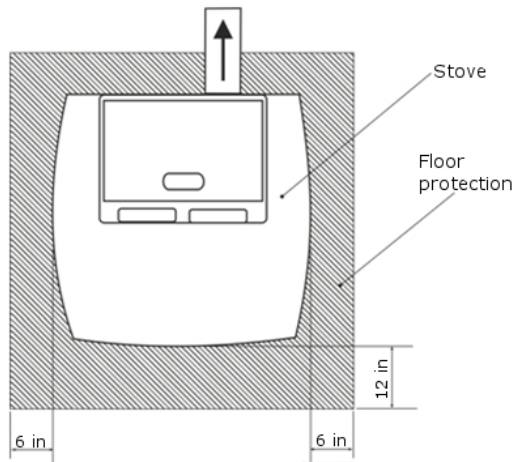

Fig. 5

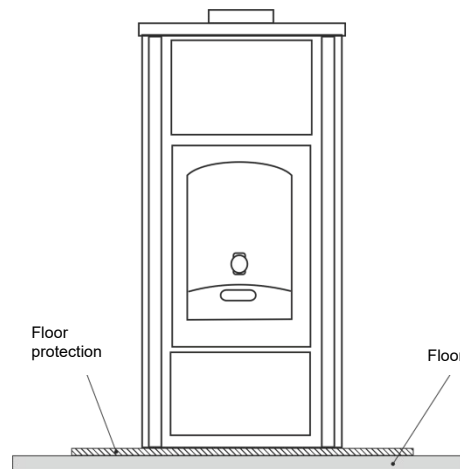

Fig. 6

4.4 Minimum distances for positioning air intake vents

Pellet stove combustion air intake vents cannot be connected to an air distribution system or directly to a wall-mounted air intake vent.

Correct and safe positioning of the air intake vent must comply with the measures and requirements described in paragraph 1.3.

There are distances to be respected in order to avoid that combustion air be removed by another source; for example, a window opening can suck the air outside, making it miss the stove.

The air intake vent must be located at least:		
5 feet (1.5 m)	Under	Doors, windows, fume exhaust outlets, air gaps, etc.
5 feet (1.5 m)	Horizontally away	
1 foot (0.3 m)	Over	
5 feet (1.5 m)	Away from	Fume output

4.5 Vent exhaust duct

4.5.1 General notes

The stove requires a UL listed pellet vent, so the venting system shall be approved for pellet stoves by a certified testing Laboratory

**DO NOT CONNECT THIS UNIT TO A CHIMNEY FLUE SERVING ANOTHER APPLIANCE
INSTALL VENT AT CLEARANCES SPECIFIED BY THE VENT MANUFACTURER**

Construction of the exhaust duct must be done by specialised personnel or companies, as reported in the following manual. Always create the exhaust system so that periodic cleaning is assured without having to dismantle any parts.

The chimney draft must be at least 6 Pa. The measurement must always be carried out with the device warm (nominal heat output)

If the draft exceeds 15 Pa, it is necessary to reduce it by installing a special device on the exhaust pipe or in the chimney, according to current regulations.

4.5.2 Tubes and maximum usable lengths

Painted aluminised steel tubes, stainless steel tubes (Aisi 316) or porcelain tubes. Flexible hoses are permitted if they fall within the limits prescribed by law (in stainless steel with smooth inner wall).

TYPE OF SYSTEM	WITH DOUBLE-WALL TUBE
Minimum length	10 feet (3 m)
Maximum length (with 3 90° curves)	26 feet (8 m)
Maximum number of curves	2

NOTE: load losses of a 90° curve can be equated with those of 1 metre of tube; the serviceable T-connection is to be considered as a 90° curve.

4.5.3 Holes for exhaust tube passage on walls or roof

Once the location of the stove has been decided (section 4.1), you will have to drill the hole for passage of the fume exhaust tube. This varies depending on the type of installation (therefore on the exhaust tube diameter, see 4.5.2) and on the type of wall or roof to be crossed (table 3).

The insulator must be of mineral origin (rock wool, ceramic fibre) with a nominal density greater than 80 kg/m³.

	Insulation thickness	Diameter of holes to be created [mm]
Wooden wall, or wall which is flammable or has flammable parts	4 in	12 in
Concrete wall or roof	2 in	9 in
Brick wall or roof	1,5 in	7 in

4.5.4 Using a traditional type chimney flue

If you wish to use an already existing chimney flue, it is advisable to have it checked by a professional chimney sweep to ensure that it is watertight. This is because fumes, being slightly pressurised, could infiltrate cracks in the chimney flue and invade living spaces. If an inspection finds that the chimney flue is not perfectly intact, it is advisable to intubate it with new material. If the existing chimney is large, we recommend inserting a tube with a maximum diameter of 6 in.

It is also advisable to insulate the vent exhaust duct. Figs. 7 and 8 demonstrate the solutions to adopt if you want to use an existing chimney flue.

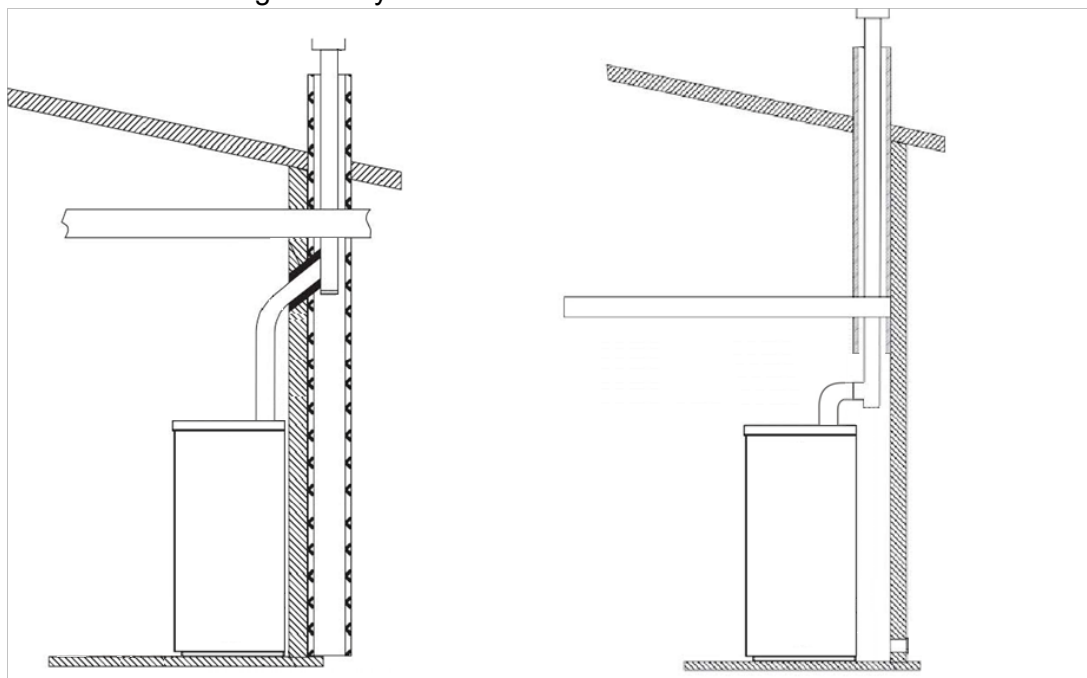

Fig. 7

Fig. 8

4.6 Using an external fume duct

An external fume duct can be used only if it meets the following requirements:

- Only insulated tubes (double wall) in stainless steel, secured to the building (Fig.9) should be used.
- An inspection area should be created at the base of the duct for performing periodic checks and maintenance.
- It should be equipped with a windproof chimney cap and observe the distance "d" from the ridge of the building as described in par. 1.2.
- Fig. 9 shows the solution to be utilised when using external fume ducts.

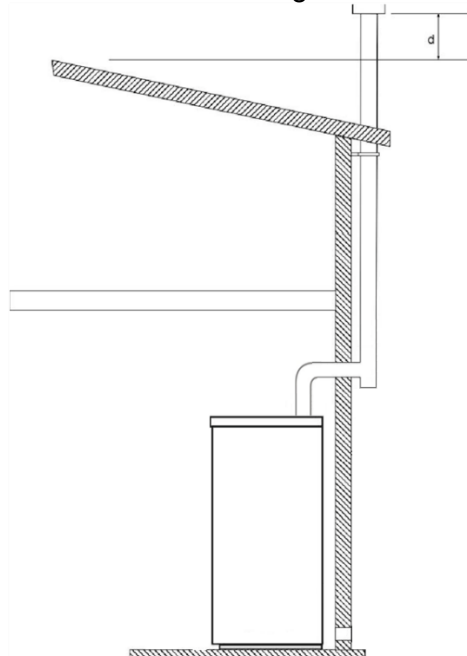

Fig. 9

5 ASSEMBLY

5.1 General notes

Here are some general recommendations to follow in order to prevent accidents or damage to the product:

- Unpacking and installation must be performed by at least two people.
- **All handling operations must be carried out using appropriate means and in full compliance with safety regulations.**
- The positioning of the packed product must be maintained in accordance with the guidelines supplied by pictograms and written on the packaging.
- If using ropes, straps, chains, etc., make sure they are suitable for the weight to be unloaded and are in good condition.
- When moving the package, move with slow and continuous movements to avoid tearing the ropes, chains, etc.
- Do not tilt excessively in order to avoid overturning.
- Do not stand within range of the loading/unloading means (forklifts, cranes, etc.).

5.2 Unpacking

Unpack the product being careful not to damage or scratch it. Remove the accessory package and any pieces of polystyrene or cardboard used to block removable parts, etc. from the stove furnace. Also remember not to leave packaging components (plastic bags, polystyrene, etc.) within the reach of children, as they could be potential sources of danger. Dispose of them according to regulations.

6 USE

- All local regulations, must be observed when installing the unit.
- Improper installation or use of the device can result in forfeiture of the warranty.
- Do not use the unit as an incinerator or in any other way other than that for which it was designed. No other fuel besides wood pellets must be used.
- Do not use liquid fuels.
- The device, especially the external surfaces, gets very hot to the touch when in use. Handle with care to avoid burns.
- Do not make any unauthorised modifications to the device.
- Only use original replacement parts recommended by the manufacturer.
- This wood heater has a manufacturer-set minimum low burn rate that must not be altered. It is against federal regulation to alter this setting or otherwise operate this wood heater in a manner inconsistent with operating instruction in this manual.
- This wood heater needs periodic inspection and repair for proper operation. It is against federal regulations to operate this wood heater in a manner inconsistent with operating instruction in this manual.
- Flues gases contain carbon monoxide (CO), it is recommended to install smoke monitors and CO monitors for areas that are expected to generated CO. Inspect the the chimney to minimize visible emissions.
- Soot and Flyash: Formation and Need for Removal—The products of combustion will contain small particles of flyash. The flyash will collect in the exhaust venting system and restrict the flow of the flue gases. Incomplete combustion, such as occurs during startup, shutdown, or incorrect operation of the room heater will lead to some soot formation which will collect in the exhaust venting system. The exhaust venting system should be inspected at least once every year to determine if cleaning is necessary.

In general

- Make sure that the room where the stove is to be installed offers sufficient ventilation (see section 1.3 “External air intake vent”).
- Periodically check (or have someone check) the cleanliness of exhaust fumes.
- When the stove is in operation, remove the extractable handle and place it in the appropriate compartment located at the rear of the stove (fig.11)
- **CAUTION: keep all flammable products well away from the stove when it operating (MINIMUM: 40 feet from the front wall).**
- **CAUTION: to prevent the escape of fumes, the combustion chamber must be kept closed except during cleaning operations, to be carried out with the stove off.**
- **CAUTION: removing the safety guard inside the tank is strictly prohibited.**
- **CAUTION: in the event of pellet supply while the stove is on, make sure that pellets are not finished and that the flame remains present in the brazier. Also avoid the fuel sack from coming into contact with hot surfaces.**
- **CAUTION: remove any residue of unburned pellets caused by failed ignitions before you start the stove again.**
- **CAUTION: if during the ignition phase, the stove does not start and you notice a lot of smoke in the combustion chamber, immediately turn off the stove and replace pellets in use, as these may be too high in moisture. Forcing ignition could make your stove a hazard.**
- **CAUTION: if during cleaning, you find traces of spongy or hard (though not ash) pellets, replace the pellets being used as this residue may come from scraps of low-quality sawdust not usable in this type of stove. Forcing ignition can cause a fire or strong production of fumes in the chimney.**
- **CAUTION: monitor proper combustion of the pellets in the brazier. If you should detect accumulations of unburned pellets, IMMEDIATELY TURN OFF the stove and contact the service centre.**
- **CAUTION: exercise extreme caution in the presence of children, to prevent them from standing in front of the stove.**

6.1 Components

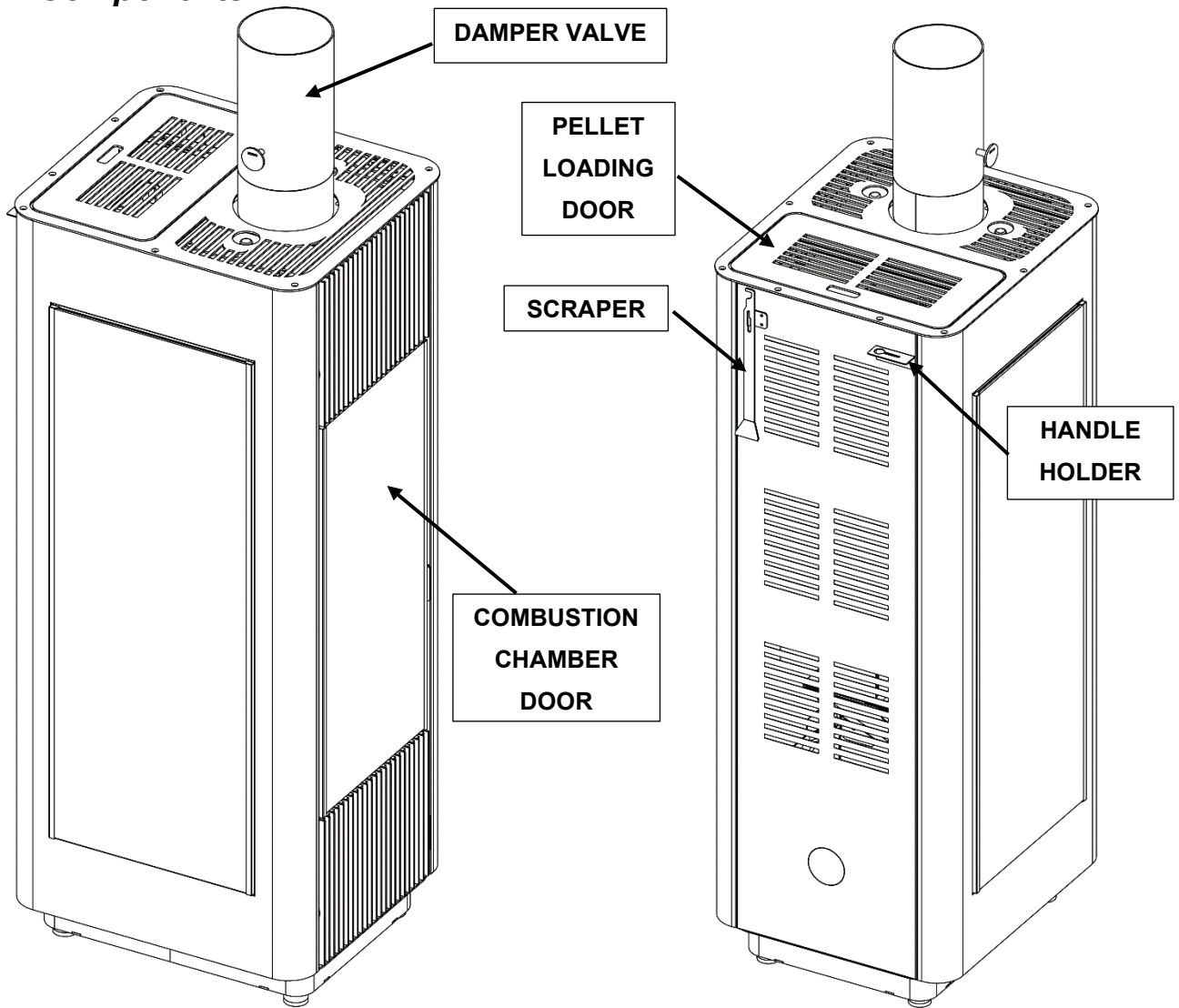

Fig.10

Fig.11

6.2 Filling up the tank

- Open the lid and move the pellet loading lever to the "Stop" position (fig. 12);
- Open the tank lid (fig. 13).

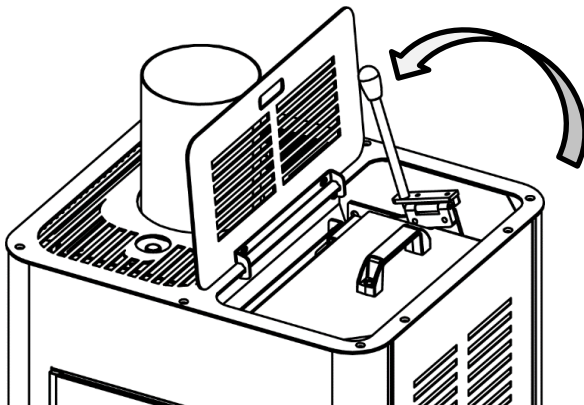

Fig. 12

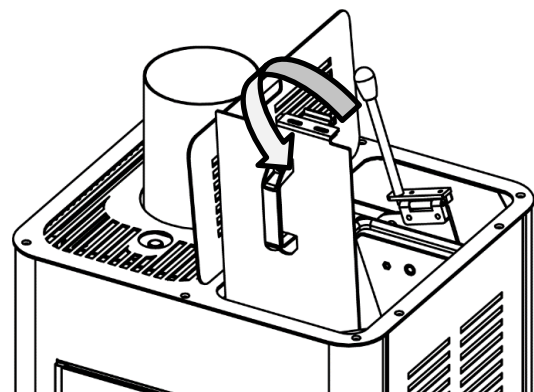

Fig. 13

You can load pellet also when the stove is working.

6.3 Ignition

Once the tank has been filled up, the stove is ready to be turned on. Put the lever in position “Go” and lower it to the rest position (*fig. 14*);

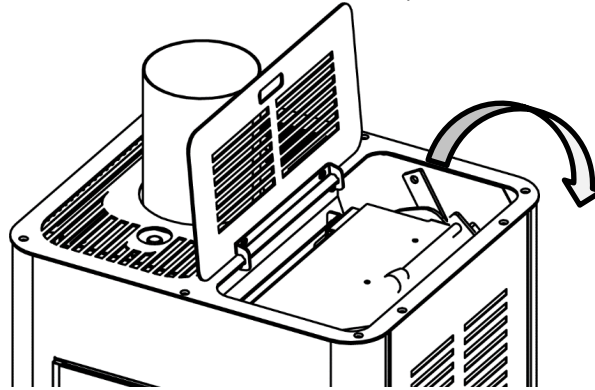

Fig. 14

The pellets will fall down until the brazier is full; now you can open the main door and position a solid or gel-like ignited on top of the pellets in the brazier and light it using a flame. Leave the door ajar for a couple of minutes or even longer (this depends on the room temperature and on the chimney flue). Close the door only when the flame reaches a minimum height of about 3 inches, so as to lick the holes located in the rear wall. Now the stove is turned on.

The fire door is equipped with a return spring that prevents accidental maximum opening.

ATTENTION: do not touch the door with bare hands while the stove is working.

CAUTION: *always clean the brazier prior to each ignition to avoid false starts, if there is little ash residue, clean it by means of the shaker (See paragraph 6.7); in case of hard-to-clean ash residue, take out the brazier and manually shake it.*

CAUTION: *always carry out this operation with the stove switched off and cooled down.*

CAUTION: RISK OF BURNS.

6.4 Combustion mode

Using the air adjustment lever positioned under the upper door, it is possible to vary the combustion air inlet and consequently the power of the stove.

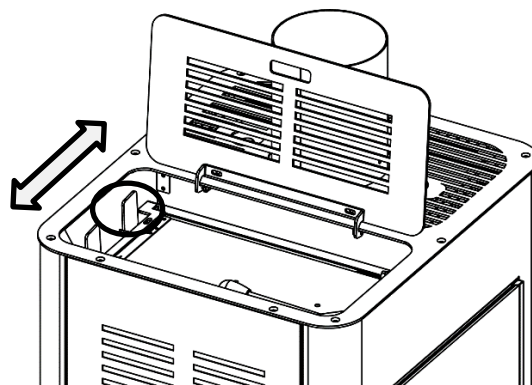

Fig. 15

ATTENTION: The minimum power of the stove depends on the draft of the chimney flue

6.5 Shutdown

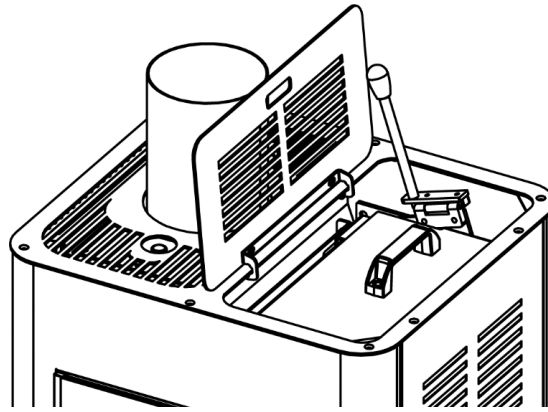

Fig. 16

By moving the lever in position “Stop” (fig. 16) the fall of pellet into the brazier will stop; combustion will continue for about 20 minutes, after which the stove will switch off.

To switch it back on, move the lever in position 2, place a solid or gel-like igniter on top of the pellets and light it up with a flame

CAUTION: to prevent burns wait at least 15 minutes before switching the stove back on.

CAUTION: RISK OF BURNS.

CAUTION: do not touch the brazier after switching off the stove.

6.6 Cleaning the exchanger

Hook the handle on the pin (fig. 17) and lift it up repeatedly causing the internal springs to shake and consequently the ash to fall into the combustion chamber; repeat this operation on the other pin

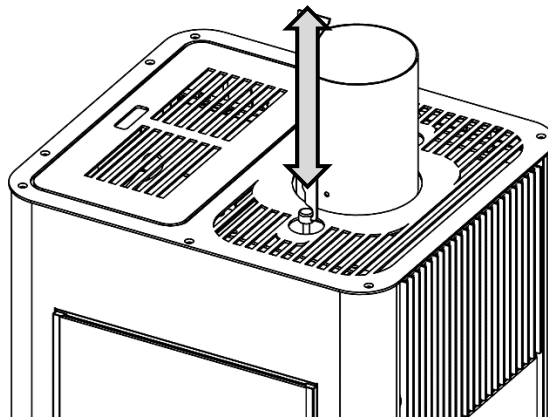

Fig. 17

The exchanger must be cleaned at least once a week; if the stove is used a lot (more than 8 hours a day), it is recommended to clean it every 3 days.

It is recommended to carry out this operation when the stove is cold to avoid getting burned; however, it can also be done while the stove is working, provided that utmost attention is paid to hot surfaces.

Do not leave the handle hooked up to the pin after cleaning the stove while it is working; put it away in the special compartment.

CAUTION RISK OF BURNS.

CAUTION: Do not touch the pin with bare hands while the stove is working to avoid getting burned

6.7 Cleaning the brazier with the shaker

To keep the flame always live and at maximum efficiency and avoid the formation of smoke, during operation it is necessary to clean the brazier using the specific shaker lever (*fig.18*), which drops the excess ash in the drawer (**no more than two or three blows**).

The frequency of this operation depends on the quality of the pellet used

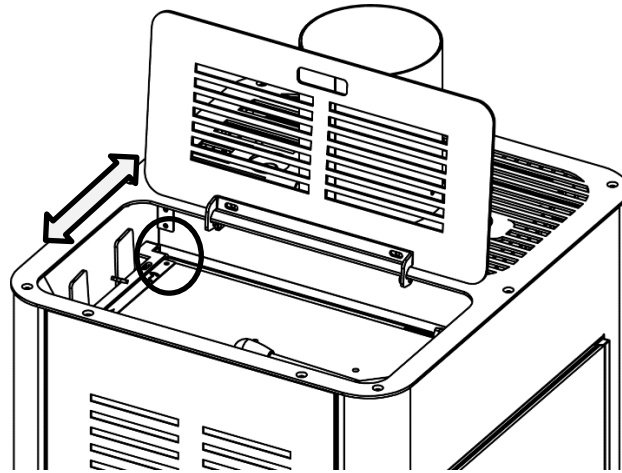

Fig. 18

CAUTION RISK OF BURNS.

7 WARNINGS AND MAINTENANCE



WARNING

The maintenance and care must be carried out only with cold device.

You should only use spare parts approved and supplied by Laminox Idro Srl please contact your specialized retailer if you require spare parts. You must not make any changes to the device!!!

The periodic maintenance, as indicated in this Installation and Operating Instruction, must be performed with the utmost care after reading the instructions, procedures and frequency described in this manual. Check the external air intake, by cleaning it, at least once a year. The flue must be regularly swept by the chimney sweeper. Let your chimney sweeper in charge of your area check the regular installation of the device, the connection to the flue and the aeration.

All maintenance operations (cleaning, replacements, etc.) should be carried out when the fire is out and the stove is cold. In addition, do not use any abrasive substances.

CAUTION: FAILURE TO CLEAN AFFECTS SAFETY

7.1 Opening the door

The door must remain closed during operation. The door should be opened only with the stove off and cooled down to perform maintenance and routine cleaning.

7.2 Ashes cleaning and disposal

Check the ash drawer every two days to see if it needs emptying

The ash collection compartment must be emptied regularly so as to impede combustion residue from arriving at the brazier support.

CAUTION: ashes keep embers on for a long time!!!



WARNING

Ashes should be placed in a metal container with a tight-fitting lid. The closed container of ashes should be placed on a non-combustible floor or on the ground, well away from all combustible materials, pending final disposal. If the ashes are disposed of by burial in soil or otherwise locally dispersed, they should be retained in the closed container until all cinders have thoroughly cooled.

7.3 Brazier cleaning

When the flame becomes a red colour or is weak accompanied by black smoke, it may mean that there are ash deposits or incrustations which are not allowing correct stove operation and which must be removed.

Every two days, remove the brazier by simply lifting it from its housing, then clean it of ash and any incrustations which could have formed, with particular attention to freeing clogged holes using a pointed tool.

This operation is necessary in particular the first few ignitions, especially when using different quality pellets. The timing of this operation is determined by the frequency of use and the choice of fuel. It is advisable to also check the brazier support, emptying it of any ashes.

CAUTION: before igniting the stove, check that the brazier is properly inserted and pushed back toward

7.4 Ash drawer cleaning

Check the ash drawer every two days to see if it needs emptying

The ash collection compartment must be emptied regularly so as to impede combustion residue from arriving at the brazier support.

CAUTION: ashes keep embers on for a long time!!!



WARNING

Ashes should be placed in a metal container with a tight-fitting lid. The closed container of ashes should be placed on a non-combustible floor or on the ground, well away from all combustible materials, pending final disposal. If the ashes are disposed of by burial in soil or otherwise locally dispersed, they should be retained in the closed container until all cinders have thoroughly cooled.

7.5 Combustion chamber cleaning

Clean the combustion chamber weekly, removing ashes accumulated in the chamber using a vacuum cleaner.

Note: Use a vacuum cleaner designed for the suction of ashes for this type of cleaning.

Once a week, open the front grille and pull the cleaner rod knob towards you at least 3 times.

7.6 Smoke chamber cleaning

Generally, clean the smoke chamber once a year (preferably at the beginning of the season) for best stove operation. The frequency of this operation depends on the type of pellet used and the frequency of use. Contact a Technical Assistance Centre for this type of cleaning.

7.7 Exhaust system cleaning

Until you are reasonably experienced regarding operating conditions, it is advisable to perform this service at least monthly. Remove the T-fitting cap and proceed with duct cleaning. If necessary, at least the first few times, request assistance from a qualified technician.

7.8 Cleaning metal and ceramic parts

Use a soft cloth moistened with water to clean metal stove parts.

Never clean metal or ceramic parts with alcohol, thinners, petrol, ketones or other degreasers.

Use of these substances frees the company from all liability. Discolouration of metal parts can be the result of improper use of the stove.

7.9 Pellet slide cleaning

With the scraper (Fig. 19), clean the pellet slide (Fig. 20) from any incrustations that can slow down or block the pellets' descent to the brazier.

It is recommended to do out this operation before each ignition in order to maintain the correct functioning.



Fig. 19

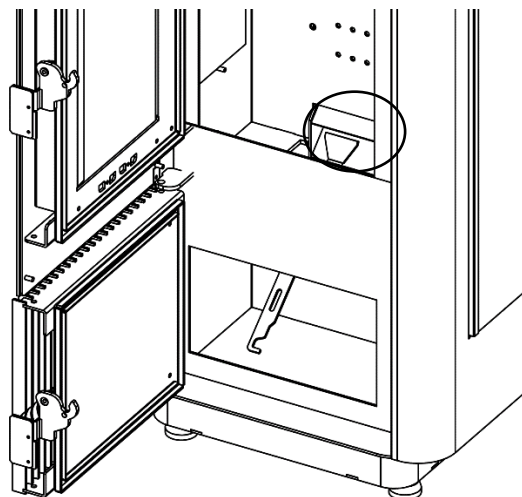

Fig. 20

7.10 Cleaning glass

Door glass must be clean (cold). Prevent corrosive substances from coming into contact with the paint on the stove as these can cause damage. Do not use any material that can scratch or damage the glass.



WARNING

The cleaning of glass must be carried out only and exclusively with cold device to avoid the explosion of the same glass.

For the cleaning, it is possible to use specific products or a wet newspaper paper ball passed in the ash to rub it. Do not use cloths, abrasive or chemically aggressive products by cleaning the hearth glass

7.11 Broken glass

The stove is equipped with 5 mm ceramic glass that is resistant to a thermal shock of 1350°F. This glass can break only due to a strong impact or misuse. Do not slam the door or hit the glass. In case of breakage, replace with an original replacement part only. (See paragraph 7.15)



WARNING

Break of glasses: ceramic-based glasses can resist up to a heat shock of 1350°F, therefore they are not affected by thermal shock issues. Their break can be caused by mechanic shocks, such as striking or slamming shut of the door. Therefore, their replacement is not included in the warranty

Do not operate this unit with broken glasses

Broken or damaged glass components shall be removed and reinstalled taking care about using proper gaskets, cushioning devices and other accessories, maintaining edge clearances (See paragraph 7.15)

Replace glass only with glass supplied from the manufacturer or distributor of this appliance

7.12 Stove inactivity

At the end of the season, perform the following operations:

- Remove all pellets from the tank and from the feed screw.
- Thoroughly clean the brazier, the support brazier, the combustion chamber and the ash drawer.
- Thoroughly clean the smoke exhaust system: contact a professional chimney sweep for this purpose.
- Clean all dust, spider webs, etc. from the area behind the panels of the inner cladding once a year.
- Clean fans thoroughly.

7.13 Routine and special maintenance

This pellet heater needs periodic inspection and repair for proper operation. It is against federal regulation to operate this pellet heater in a manner inconsistent with operating instructions in this manual

These operations should be programmed ANNUALLY with a Technical Assistance Centre and are necessary to ensure the maintenance of product efficiency and ensure safe operation.

- Thoroughly clean the combustion chamber and the heat exchanger.
- Smoke motor, dismantling and cleaning of the smoke exhaust duct, new silicone where required.
- Inspection and verification of gaskets, springs and replacement and application of the silicone where required
- Tank, emptying and cleaning.
- Check and replacement, if necessary, of components that are subject to wear: brazier, ash drawers, etc.

7.14 Routine maintenance performed by qualified technicians

Using wood as solid fuel, the generator requires annual routine maintenance, which must be performed by a qualified technician, using only original spare parts.

Failure to comply can jeopardise the safety of the appliance and make the warranty null and void.

Respecting the frequencies of cleaning reserved for the user described in the use and maintenance manual, the generator is guaranteed correct combustion over time, preventing any anomalies and/or malfunctioning that could require more interventions of the technician. Requests for routine maintenance are not contemplated in the product warranty.



WARNING

Routine maintenance must be performed at least once a year.

The annual routine maintenance must be performed by a qualified technician.

Using only original spare parts. Failure to comply can jeopardise the safety of the appliance and make the warranty null and void.

7.15 Spare parts replacement

Use only ceramic type glass

The gaskets guarantee the tightness of the product and its consequent good functioning. They must be controlled periodically. They must be replaced immediately if they are worn or damaged. These operations must be carried out by a qualified technician.

Ceramic Glass dimensions: 306 x239 mm (12" x 9,4"); Thickness 5 mm

Door tricovet gasket: *Diam.* 10 mm (0,39"); *L.* 1570 mm / (62")

For all other spare parts please contact your dealer using the list on the following pages as a reference.

Spare parts replacement operations must always be carried out by a qualified technician

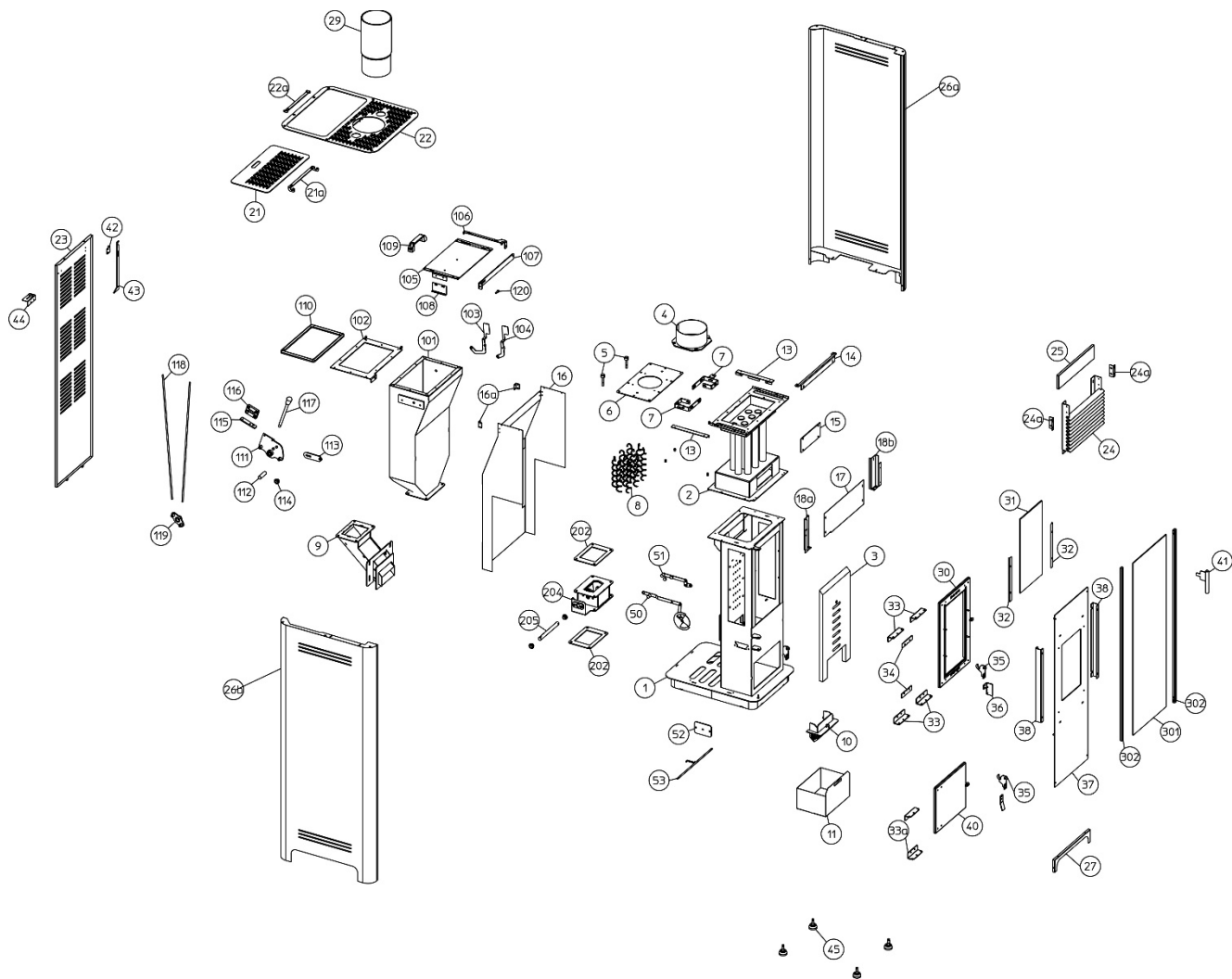

Ref. Drawing	Product code	Laminox description	N° Per Kit
1	LYD-STR	structure	1
2	PHX-GRF	fumes circulation	1
3	PHX-VCC	Combustion chamber insulation	1
4	PHX-UF150	Smoke outlet	1
5	JSN9-PMT	Turbulators movement pin	2
6	PHX-TIT	Turbulators inspection cap	1
7	PHX-PT	Turbulator holder	2
8	PHX-TM	spring turbulator	8
9	PHX-SPI	pellet slide inox	1
10	HS13-BRA	Brazier	1
11	PHX-CC	ash drawer	1
13	PHX-AOL	lateral horizontal angle bracket	2
14	PHX-AOF	front horizontal angle bracket	1
15	PHX-TIG	fumes circulation inspection cap	1
16	PHX-DPS	tank heat shield diaphragm	1

16a	PXH-SQC	closure brackets heat buffer	1
17	PHX-TRF	finishing frontal plug	1
18a	PHX-ANSX	Left Angle bracket	1
18b	PHX-ANDX	Right angle bracket	1
50	PHX-MOV-AR	air movement	1
51	PHX-MOV-SC	shaker movement	1
52	PHX-TSC	shaker plug	1
53	PHX-SCT	shaker burner	1
43	PHX-RAS	Scraper water slide pellet	1
24b	LYD-SCS	Front panel support	2
--	STP-VF-150	Throttle	1
30	PHX-PRT	fire door (without glass and handle)	1
31	PHX-VTR-IN	Internal door glass	1
32	PHX-SRV	Glass holder brackets	2
33	PHX-SPA	front plate door support	4
34	PHX-TAS	explosion-proof plug door	2
35	PHX-MIN	interior handle	2
36	PHX-MEX	external handle	1
37	LYD-PAS	front door plate	1
38	PHX-ANR	reinforcement angle bracket	2
40	LYD-PRC	ash door	1
41	STP-MCE	removable handle	1
301	LYD-VTR-EX	External front glass	1
302	LYD-GPV	glass guide	2
--	STP-GS10	Door seal	1
--	STP-GA2	Adhesive glass seal	1
114	STP-BRO	Bushing	4
--	PHX-SAS	assembled tank	1
101	PHX-SRB	tank main body	1
102	PHX-CS	tank frame	1
103	PHX-LRA	air regulation lever	1
104	PHX-LSC	shaker lever	1
105	PHX-CSP	pellet tank cover	1
106	PHX-CCS	hinge tank cover	1
107	PHX-ABC	Tank locking rod	1
108	PHX-BAP	Tank opening lock	1
109	PHX-MCS	handle cover tank	1
110	STP-GAS	Pellet tank adhesive seal	1

111	PHX-SLC	support locking lever	1
112	PHX-AMC	shaft opening mechanism	1
113	PHX-BAS	Safety rod lock	1
115	PHX-SPC	hinge support	1
116	PHX-CRN	snap hinge	1
117	PHX-LCV	closing lever pellet valve	1
118	PHX-AMB	Balance movement rod	2
119	PHX-FAB	fulcrum locking rod	1
21	LYD-CP	Top cover	1
21a	PHX-CM	mobile hinge	1
22	LYD-TS	Top	1
22a	PHX-CF	fixed hinge	1
23	PHX-DP	back diaphragm	1
24	LYD-GS	Lydia grid	1
25	LYD-CS	Front panel	1
26a	LYD-FDX	Lydia right side panel	1
26b	LYD-FSX	Lydia left side panel	1
29	PHX-DAM	Damper valve	1
27	LYD-ZRF	Finishing plinth	1
45	STP-PIE	Adjustable foot	4
42	PHX-GR	scraper hook	1
44	PHX-SP	handle support	1
202	LMX-GA2	silicone seal	2
204	PHX-CVP	valve body pellet	1
205	PHX-BR	rotation shaft	1

8 WARRANTY

8.1 Certificate of warranty

The purchaser is invited to:

- Examine the instructions for the installation, use and maintenance of the stove.
- Examine the conditions of warranty shown below and the "*Limited Warranty certificate*" included in this manual

8.2 Condition of warranty

The limited warranty covers defects of manufacturing materials, on condition that the product has not been broken due to an incorrect use, carelessness, wrong connections or errors of installation.

The following are not covered by guarantee:

- *vermiculite (Firex 600)*;
- *the glass of the door*;
- *the fibre gaskets*;
- *the painting*;
- *the fire pot*;
- *the cast majolica*;
- *any damage caused by inappropriate installation and/or handling of the stove and/or shortcomings by the consumer*

. The use of poor-quality pellets or of any other material could damage components of the stove causing the termination of their guarantee and the annexed responsibility of the manufacturer.

The pellets which meet the requisites listed in the chapter on them should be used.

All damage caused by transport are not acknowledged, therefore please carefully check the goods on receipt, immediately advising the dealer of any damage.

All the manufacturer's guarantees are shown here and no complaint may be made to the manufacturer according to any other guarantee, report or request.

For warranty claims and instructions for return shipments please refer to your local dealer.

8.3 Information and problems

For any information or problems, please contact your dealer or service centre, the only people who can meet any request you may have end, if necessary, who can intervene directly

Limited Warranty certificate

Subject matter

Laminox Srl, provides a warranty on all product marketed under the *Laminox Idro* brand and installed professionally by authorized personnel within the North American territory: subject to limitations set out below mentioned.

The manufacturer's warranty allows customers to request the free of charge replacement or repair of product parts solely, in case where non-conformance due to manufacturing defects is detected and acknowledged by trained personnel.

During the warranty period, Laminox undertakes to correct defects caused by manufacturing defects, at no cost to the Customer, through its network of customer services, which the Customer can contact by contacting the dealer. In any case, Laminox points out that the appliance must be installed in an easily accessible place in accordance with current legislation. Otherwise, the costs necessary to intervene will be entirely borne by the Customer.

Warranty period

Laminox S.r.l. guarantees its products for 24 months (two years) from the date of purchase by the end customer (hereinafter Customer), proven by a valid fiscal document issued by the authorized reseller (receipt, invoice) that identifies the product purchased and the date of purchase and/or delivery of the same.

Validity

This warranty is valid exclusively for products installed in North America

The warranty includes the free repair or replacement of the component parts of the appliance which are defective at the origin due to manufacturing defects, with the exception of the hypotheses listed in the "Exclusions" paragraph.

The right to the guarantee will be proven by this original certificate, from which the model, the serial number of the product, the date of purchase and the company name of the retailer can be deduced and by a document valid for tax purposes, issued by the retailer at the time of purchase.

The warranty is recognized as valid provided that:

- 1) The appliance has been installed by qualified personnel in compliance with the regulations in force on the matter, respecting the instructions contained in this use and maintenance instructions;
- 2) The appliance is used according to the methods described in this use and maintenance instructions;
- 3) The lack of conformity is reported;
- 4) This certificate is accompanied by a purchase document certifying payment for the goods and showing the retailer's company name, model and purchase price.

Exclusions

The warranty is not recognized in the following cases:

- 1) The terms of validity have not been respected;
- 2) The installation has not been carried out in compliance with the regulations in force on the matter, respecting the prescriptions contained in this use and maintenance instructions. Installations that do not comply with current standards will void the product warranty, as will improper use and lack of maintenance as foreseen by the manufacturer;
- 3) It is found by the customer service that conditions external to the functioning of the product have caused it;
- 4) For interventions aimed at explaining the functioning of the product, periodic checks and maintenance and all that, at the time of sale, had been brought to the attention of the Customer or that the latter could not reasonably ignore;
- 5) Negligence in maintenance, carelessness, tampering, accidental breakage, damage in transport,

- incorrect handling, as well as improper use and maintenance by the Customer is found;
- 6) Combustion of materials that do not comply with the types indicated in the use and maintenance manual;
 - 7) Damage caused to the equipment by atmospheric and natural events (such as lightning, floods, fires, earthquakes) or by acts of vandalism;
 - 8) Operational alterations due to climatic, atmospheric, environmental or other conditions;
 - 9) Acknowledgment by the customer service of the presence of non-compliant electrical and/or hydraulic systems or fume ducts;
 - 10) For which an insufficient or non-compliant flow rate of the electrical systems is found;
 - 11) No defect has been found, as reported by the Customer, or for generic operating problems deriving from a wrong impression by the user (problems with noise, heating, timer programming, etc.);
 - 12) Interventions for calibration or adjustment of the product in relation to the type of fuel used or the particularities of the installation;
 - 13) Transport damage not dependent on the manufacturer. In this regard, it is recommended to carefully check the material upon receipt, immediately notifying the retailer and reporting the annotation both in the transport document and on the carrier's copy.

Laminox S.r.l. declines all responsibility for any damage that may directly or indirectly be caused to people, things or animals as a result of failure to observe all the instructions indicated in the specific instruction booklet and concerning installation, use, operation and maintenance of the appliance.

For the period of inefficiency and for direct or indirect damage due to or dependence on the product, no compensation is recognized.

The interventions carried out for the replacement of components subject to wear and/or removable are also excluded from the guarantee, unless their breakage and/or their malfunctioning are not attributable to original defects: - *vermiculite (Firex 600)*;

- *the glass of the door*;

- *the fibre gaskets*;

- *the painting*;

- *the fire pot*;

- *the cast majolica*;

- *any damage caused by inappropriate installation and/or handling of the stove and/or shortcomings by the consumer*

First ignition test (for a fee)

This product requires first start-up testing by an authorized customer service which will regulate the operating parameters and provide all the information for correct use.

It is essential to have the product function tested before completing any wall finishes (smoke duct covers, coverings, painting, etc.). The company assumes no responsibility for any damage and consequent costs of restoring the finishes mentioned even if they were to result from the replacement or repair of non-functioning parts.

Downtime period

In case of product malfunction, the customer service shall arrange to repair the product as quickly as possible, without prejudice to the fact that no compensation will be granted for the downtime period

Important: The assistance interventions must be carried out by the customer service, in total safety according to the current provisions of the law on the subject. The means necessary for the safe execution of the assignment (scaffolding, handling equipment, etc.) will be procured by the Client and the consequent expenses will be borne exclusively by him. If the technician recognizes the defect as prescribed by the laws in force regarding safety. He may legitimately refuse to carry out the requested intervention. by charging the Client the cost of the exit.

1. The technician has the task of restoring the conformity of the product on the basis of the provisions of the guarantee conditions;
2. The technician is the only person competent to establish the correct functionality of the product and evaluate its possible irreparability on site. In this second hypothesis, the product must be sent, with suitable packaging, to the Laminox company for repair and general testing with costs to be borne by the customer. In cases of irreparability, the replacement can be carried out only following the written consent of the manufacturer, leaving unchanged the expiry date and the terms of guarantee acquired at the time of purchase of the product;
3. The technician will process requests for intervention for repairs under warranty promptly, compatibly with organizational requirements. In any case, however, the manufacturer cannot be held responsible for any inconvenience caused by any delays in carrying out the intervention.

Once the warranty period stipulated in the contract has expired, the costs for any restoration work must be borne by the Customer. In this case, the Customer can contact the TAC network, from which he can obtain, in addition to a high professional service, original, tested and guaranteed spare parts.1.

REFERENCES STANDARDS:

ASTM E1509
UL 1482
ULC S627
UL 181
UL 641
ULC S609
NFDA (Fire) 211

Laminox S.r.l. reserves the right to change the characteristics and data reported in the following document at any time and without warning in order to improve their products. This manual, therefore, cannot be considered as a contract with third parties.

Updated manuals and drawings are available at website www.laminox.com.

PLEASE CONTACT YOUR DEALER FOR ANY SERVICE OR QUESTION

Appliance information:

SERIAL NUMBER _____

DATE PURCHASED _____

DATE INSTALLED _____



Dasa-Räger
EN ISO 9001 (2000)
IQ-0502-09

Laminox S.r.l. Hydro Division
Zona Industriale Callarella, 261/263 – 62028 SARNANO (MC) Italy Tel.
+39 0733.657.622 – Fax +39 0733.657.494
www.laminox.com e-mail: idro@laminox.com

Dry Gas Meter Calibration

DUT

Manufacturer: APEX
 Model: XC-60
 Lab ID #: 53
 Serial #: 1902130
 Calibration Date: 8/2/2023
 Calibration Expiration: 2/2/2024
 Barometric Pressure: 29.96 in. Hg



Equipment Used:	Ref. Std. DGM	Thermometer	Barometer	Manometer
Manufacturer: Apex		Fluke	Aquatech	Dwyer
Model: SK25DA		52 II	DBX2	475
Lab ID#: 47		196	202	174
Calibration Expiration Date: 4/17/2024		11/29/2023	5/23/2024	4/21/2024
Calibration γ Factor: 0.9988				

Use in accordance with EPA Method 5, sections 10.3 and 16.1. Use only calibrated, NIST traceable reference standard DGM. Calibrate over expected operating flow range of DUT.

Calibration Data	Run 1	Run 2	Run 3
Standard DGM Initial Volume (L)	0.000	0.000	0.000
Standard DGM Final Volume (L)	177.098	365.328	139.901
Standard DGM Temperature (°F)	75.0	78.0	78.0
Standard DGM Pressure (in H ₂ O)	0.00	0.00	0.0
DGM Initial Volume (ft ³)	0.000	0.000	0.000
DGM Final Volume (ft ³)	6.200	13.217	5.120
DGM Temperature (°F)	81.0	97.0	99.0
DGM Pressure (in H ₂ O)	3.09	2.25	1.9
Net Volume for Standard DGM (ft ³)	6.254	12.901	4.941
Net Volume for DGM (ft ³)	6.200	13.217	5.120
Dry Gas Meter γ Factor	1.011	1.004	0.997
γ Factor Deviation From Average	1.011	1.004	0.997

Average Gas Meter γ Factor

1.004

Measurement Uncertainty: Total measurement uncertainty +/- 0.748% RD, K=2

Calculations:

- Deviation = |Average value for all runs - current run value|
- $\gamma = [V_{std} \times (\gamma_{std}) \times (P_{bar} + P_{std}/13.6) \times (T_{DGM} + 460)] / [V_{DGM} \times (T_{std} + 460) \times (P_{bar} + P_{DGM}/13.6)]$

Dry Gas Meter Calibration

DUT

Manufacturer: APEX
 Model: XC-60
 Lab ID #: 54
 Serial #: 1902133
 Calibration Date: 8/2/2023
 Calibration Expiration: 2/2/2024
 Barometric Pressure: 29.88 in. Hg



Equipment Used:	Ref. Std. DGM	Thermometer	Barometer	Manometer
Manufacturer: Apex		Fluke	Aquatech	Dwyer
Model: SK25DA		52 II	DBX2	475
Lab ID#: 47		196	202	174
Calibration Expiration Date: 4/17/2024		11/29/2023	5/23/2024	4/21/2024
Calibration γ Factor: 0.9988				

Use in accordance with EPA Method 5, sections 10.3 and 16.1. Use only calibrated, NIST traceable reference standard DGM. Calibrate over expected operating flow range of DUT.

Calibration Data	Run 1	Run 2	Run 3
Standard DGM Initial Volume (L)	0.000	0.000	0.000
Standard DGM Final Volume (L)	359.264	410.313	150.574
Standard DGM Temperature (°F)	73.0	75.0	77.0
Standard DGM Pressure (in H ₂ O)	0.00	0.00	0.0
DGM Initial Volume (ft ³)	0.000	0.000	0.000
DGM Final Volume (ft ³)	12.737	14.948	5.485
DGM Temperature (°F)	85.0	93.0	101.0
DGM Pressure (in H ₂ O)	2.98	1.57	2.3
Net Volume for Standard DGM (ft ³)	12.687	14.490	5.317
Net Volume for DGM (ft ³)	12.737	14.948	5.485
Dry Gas Meter γ Factor	1.010	0.997	1.006
γ Factor Deviation From Average	1.010	0.997	1.006

Average Gas Meter γ Factor

1.004

Measurement Uncertainty: Total measurement uncertainty +/- 0.748% RD, K=2

Calculations:

- Deviation = |Average value for all runs - current run value|
- $\gamma = [V_{std} \times (\gamma_{std}) \times (P_{bar} + P_{std}/13.6) \times (T_{DGM} + 460)] / [V_{DGM} \times (T_{std} + 460) \times (P_{bar} + P_{DGM}/13.6)]$

Dry Gas Meter Calibration

DUT

Manufacturer: APEX
 Model: XC-60
 Lab ID #: 55
 Serial #: 1902130
 Calibration Date: 8/4/2023
 Calibration Expiration: 2/4/2024
 Barometric Pressure: 30.02 in. Hg



Equipment Used:	Ref. Std. DGM	Thermometer	Barometer	Manometer
Manufacturer: Apex		Fluke	Aquatech	Dwyer
Model: SK25DA		52 II	DBX2	475
Lab ID#: 47		196	202	174
Calibration Expiration Date: 4/17/2024		11/29/2023	5/23/2024	4/21/2024
Calibration γ Factor: 0.9988				

Use in accordance with EPA Method 5, sections 10.3 and 16.1. Use only calibrated, NIST traceable reference standard DGM. Calibrate over expected operating flow range of DUT.

Calibration Data	Run 1	Run 2	Run 3
Standard DGM Initial Volume (L)	0.000	0.000	0.000
Standard DGM Final Volume (L)	234.129	172.446	304.050
Standard DGM Temperature (°F)	73.0	73.0	75.0
Standard DGM Pressure (in H ₂ O)	0.00	0.00	0.0
DGM Initial Volume (ft ³)	0.000	0.000	0.000
DGM Final Volume (ft ³)	8.380	6.176	10.856
DGM Temperature (°F)	83.0	82.0	83.0
DGM Pressure (in H ₂ O)	0.00	0.00	0.0
Net Volume for Standard DGM (ft ³)	8.268	6.090	10.737
Net Volume for DGM (ft ³)	8.380	6.176	10.856
Dry Gas Meter γ Factor	1.004	1.001	1.003
γ Factor Deviation From Average	1.004	1.001	1.003

Average Gas Meter γ Factor

1.003

Measurement Uncertainty: Total measurement uncertainty +/- 0.748% RD, K=2

Calculations:

- Deviation = |Average value for all runs - current run value|
- $\gamma = [V_{std} \times (\gamma_{std}) \times (P_{bar} + P_{std}/13.6) \times (T_{DGM} + 460)] / [V_{DGM} \times (T_{std} + 460) \times (P_{bar} + P_{DGM}/13.6)]$

Dry Gas Meter Calibration

DUT

Manufacturer: APEX
 Model: XC-50-DIR
 Lab ID #: 203
 Serial #: A2204292
 Calibration Date: 8/2/2023
 Calibration Expiration: 2/2/2024
 Barometric Pressure: 29.95 in. Hg



Equipment Used:	Ref. Std. DGM	Thermometer	Barometer	Manometer
Manufacturer: Apex		Fluke	Aquatech	Dwyer
Model: SK25DA		52 II	DBX2	475
Lab ID#: 47		196	202	174
Calibration Expiration Date: 4/17/2024		11/29/2023	5/23/2024	4/21/2024
Calibration γ Factor: 0.9988				

Use in accordance with EPA Method 5, sections 10.3 and 16.1. Use only calibrated, NIST traceable reference standard DGM. Calibrate over expected operating flow range of DUT.

Calibration Data	Run 1	Run 2	Run 3
Standard DGM Initial Volume (L)	0.000	0.000	0.000
Standard DGM Final Volume (L)	145.280	144.545	148.847
Standard DGM Temperature (°F)	78.0	79.0	79.0
Standard DGM Pressure (in H ₂ O)	0.00	0.00	0.0
DGM Initial Volume (ft ³)	0.000	0.000	0.000
DGM Final Volume (ft ³)	5.087	5.161	5.355
DGM Temperature (°F)	85.0	93.0	96.0
DGM Pressure (in H ₂ O)	2.33	1.17	0.9
Net Volume for Standard DGM (ft ³)	5.131	5.105	5.256
Net Volume for DGM (ft ³)	5.087	5.161	5.355
Dry Gas Meter γ Factor	1.015	1.011	1.009
γ Factor Deviation From Average	1.015	1.011	1.009

Average Gas Meter γ Factor

1.011

Measurement Uncertainty: Total measurement uncertainty +/- 0.748% RD, K=2

Calculations:

- Deviation = |Average value for all runs - current run value|
- $\gamma = [V_{std} \times (\gamma_{std}) \times (P_{bar} + P_{std}/13.6) \times (T_{DGM} + 460)] / [V_{DGM} \times (T_{std} + 460) \times (P_{bar} + P_{DGM}/13.6)]$

Technician:

Report and Certificate of Calibration



www.Cal-Cert.com



Toll Free
800-356-4662

Address
5777 SE International Way
Milwaukie, OR 97222

Local
503-654-9620

Report #: 28140-203326-14 **Customer PO#:** 1090
Customer Name: PFS TECO
Customer Address: 11785 SE Highway 212 Ste 305
City: Clackamas **State:** OR **Zip:** 97015
Contact: Aaron Kravitz
Service Address: 11785 SE Highway 212 Ste 305 Clackamas, OR 97015

Calibration Standards

19-00269 Thermo-Hygrometer Comark SN: 6237360167 Cal: 09/14/2022 Due: 08/31/2023 Vendor: Cal-Cert Range: 122 °F 95 %RH Report #: 25699-30694-3486
LA-01776 Pressure Transducer Fluke SN: 5956001 Cal: 11/25/2022 Due: 11/25/2023 Range: 10 in H2O Report #: EVL846346

Instrument Data

Calibration Date:	March 1, 2023	Reference:	ASME B40.100
Recommended Due Date:	March 1, 2024	Cal-Cert Procedure:	CP-003
Calibration Frequency:	12 Months	Indicating System:	Digital
Manufacturer:	Newport	Temperature:	73 °F
Type:	Pressure Transducer	Humidity:	30% RH
Model Number:	Unknown	Cal Factor:	None
Serial #:	Unknown	Asset #:	54C
Capacity:	5 In H2O	Service Location:	Service Address
Tolerance:	± 1.00% of Span	As Found:	Pass
Gauge Class:	A	As Left:	Pass

Instrument Range: 5.00		Range Resolution: 0.01		Mode Verified: Pressure			
UUT Reading	Standard As Found	Standard Verification Reading #1	Error	Standard Verification Reading #2	Error	Tolerance	Expanded Uncertainty ±
In H2O	In H2O	In H2O	In H2O	In H2O	In H2O	In H2O	In H2O
0.00	0.00	0.00	0.00	0.00	0.00	0.05	0.005
0.50	0.50	0.50	0.00	0.50	0.00	0.05	0.005
1.25	1.25	1.25	0.00	1.25	0.00	0.05	0.005
2.50	2.50	2.50	0.00	2.50	0.00	0.05	0.006
3.75	3.75	3.75	0.00	3.75	0.00	0.05	0.007
5.00	5.00	5.00	0.00	5.00	0.00	0.05	0.008
3.75	3.75	3.75	0.00	3.75	0.00	0.05	0.007
2.50	2.50	2.50	0.00	2.50	0.00	0.05	0.006
1.25	1.25	1.25	0.00	1.25	0.00	0.05	0.005
0.50	0.50	0.50	0.00	0.50	0.00	0.05	0.005
0.00	0.00	0.00	0.00	0.00	0.00	0.05	0.005

Manufacturer: Newport

Type: Pressure Transducer

Serial #: Unknown

Remarks:

**We sincerely thank you for your business. Please call us at 503-654-9620 for all your sales and calibration needs.
Cleaning and preventative maintenance were performed as part of this service.**

**Cal-Cert is accredited by A2LA under Calibration Laboratory Code #4986.01.
A2LA is recognized under the ILAC mutual recognition agreement (MRA).**

This certificate is hereby issued that the above instrument was tested for accuracy with calibrated standards traceable to the National Institute of Standards and Technology (NIST). The information provided on this form complies with the data gathering and reporting requirements of ISO/IEC 17025 and ANSI/NCSS Z540.1, and meets the requirements of all applicable references and Cal-Cert procedures listed above. Any stated measurement uncertainty includes the uncertainty of the Calibration standards used, combined with the uncertainty of the measurement process using the RSS method with a k=2 for an approximate 95% level of confidence. The calibration process meets or exceeds a ratio of 4:1 unless otherwise stated.

All tolerances were derived from the applicable standards and pass/fail determination is based on those tolerances. The customer determined any recommended due dates indicated on the certificate.

This report shall not be reproduced except in full, without written approval from Cal-Cert.

Service Engineer:

Jon Rau

Date:

March 1, 2023

Technical Manager:

Marshall Doyle

Signature:



Report and Certificate of Calibration



www.Cal-Cert.com



Toll Free
800-356-4662

Address
5777 SE International Way
Milwaukie, OR 97222

Local
503-654-9620

Report #: 28140-203325-14 **Customer PO#:** 1090
Customer Name: PFS TECO
Customer Address: 11785 SE Highway 212 Ste 305
City: Clackamas **State:** OR **Zip:** 97015
Contact: Aaron Kravitz
Service Address: 11785 SE Highway 212 Ste 305 Clackamas, OR 97015

Calibration Standards

19-00269 Thermo-Hygrometer Comark SN: 6237360167 Cal: 09/14/2022 Due: 08/31/2023 Vendor: Cal-Cert Range: 122 °F 95 %RH Report #: 25699-30694-3486
LA-01776 Pressure Transducer Fluke SN: 5956001 Cal: 11/25/2022 Due: 11/25/2023 Range: 10 in H2O Report #: EVL846346

Instrument Data

Calibration Date:	March 1, 2023	Reference:	ASME B40.100
Recommended Due Date:	March 1, 2024	Cal-Cert Procedure:	CP-003
Calibration Frequency:	12 Months	Indicating System:	Digital
Manufacturer:	Newport	Temperature:	68 °F
Type:	Pressure Transducer	Humidity:	37% RH
Model Number:	Unknown	Cal Factor:	None
Serial #:	Unknown	Asset #:	54B
Capacity:	1 In H2O	Service Location:	Service Address
Tolerance:	± 1.00% of Span	As Found:	Pass
Gauge Class:	A	As Left:	Pass

Instrument Range:		1.00		Range Resolution:		0.01		Mode Verified:		Pressure	
UUT Reading	Standard As Found	Standard Verification Reading #1	Error	Standard Verification Reading #2	Error	Tolerance	Expanded Uncertainty ±				
In H2O	In H2O	In H2O	In H2O	In H2O	In H2O	In H2O	In H2O				
0.00	0.00	0.00	0.00	0.00	0.00	0.01	0.005				
0.10	0.10	0.10	0.00	0.10	0.00	0.01	0.005				
0.25	0.25	0.25	0.00	0.25	0.00	0.01	0.005				
0.50	0.50	0.50	0.00	0.50	0.00	0.01	0.005				
0.75	0.75	0.75	0.00	0.75	0.00	0.01	0.005				
1.00	0.99	0.99	-0.01	0.99	-0.01	0.01	0.005				
0.75	0.75	0.75	0.00	0.75	0.00	0.01	0.005				
0.50	0.50	0.50	0.00	0.50	0.00	0.01	0.005				
0.25	0.25	0.25	0.00	0.25	0.00	0.01	0.005				
0.10	0.10	0.10	0.00	0.10	0.00	0.01	0.005				
0.00	0.00	0.00	0.00	0.00	0.00	0.01	0.005				

Manufacturer: Newport

Type: Pressure Transducer

Serial #: Unknown

Remarks:

**We sincerely thank you for your business. Please call us at 503-654-9620 for all your sales and calibration needs.
Cleaning and preventative maintenance were performed as part of this service.**

**Cal-Cert is accredited by A2LA under Calibration Laboratory Code #4986.01.
A2LA is recognized under the ILAC mutual recognition agreement (MRA).**

This certificate is hereby issued that the above instrument was tested for accuracy with calibrated standards traceable to the National Institute of Standards and Technology (NIST). The information provided on this form complies with the data gathering and reporting requirements of ISO/IEC 17025 and ANSI/NCSS Z540.1, and meets the requirements of all applicable references and Cal-Cert procedures listed above. Any stated measurement uncertainty includes the uncertainty of the Calibration standards used, combined with the uncertainty of the measurement process using the RSS method with a k=2 for an approximate 95% level of confidence. The calibration process meets or exceeds a ratio of 4:1 unless otherwise stated.

All tolerances were derived from the applicable standards and pass/fail determination is based on those tolerances. The customer determined any recommended due dates indicated on the certificate.

This report shall not be reproduced except in full, without written approval from Cal-Cert.

Service Engineer:

Jon Rau

Date:

March 1, 2023

Technical Manager:

Marshall Doyle

Signature:



Report and Certificate of Calibration



www.Cal-Cert.com



Toll Free
800-356-4662

Address
5777 SE International Way
Milwaukie, OR 97222

Local
503-654-9620

Report #: 28140-203324-14 **Customer PO#:** 1090
Customer Name: PFS TECO
Customer Address: 11785 SE Highway 212 Ste 305
City: Clackamas **State:** OR **Zip:** 97015
Contact: Aaron Kravitz
Service Address: 11785 SE Highway 212 Ste 305 Clackamas, OR 97015

Calibration Standards

19-00269 Thermo-Hygrometer Comark SN: 6237360167 Cal: 09/14/2022 Due: 08/31/2023 Vendor: Cal-Cert Range: 122 °F 95 %RH Report #: 25699-30694-3486
LA-01776 Pressure Transducer Fluke SN: 5956001 Cal: 11/25/2022 Due: 11/25/2023 Range: 10 in H2O Report #: EVL846346

Instrument Data

Calibration Date:	March 1, 2023	Reference:	ASME B40.100
Recommended Due Date:	March 1, 2024	Cal-Cert Procedure:	CP-003
Calibration Frequency:	12 Months	Indicating System:	Digital
Manufacturer:	Newport	Temperature:	73 °F
Type:	Pressure Transducer	Humidity:	30% RH
Model Number:	Unknown	Cal Factor:	None
Serial #:	Unknown	Asset #:	53C
Capacity:	5 In H2O	Service Location:	Service Address
Tolerance:	± 1.00% of Span	As Found:	Pass
Gauge Class:	A	As Left:	Pass

Instrument Range:		5.00		Range Resolution:		0.01		Mode Verified:		Pressure	
UUT Reading	Standard As Found	Standard Verification Reading #1	Error	Standard Verification Reading #2	Error	Tolerance	Expanded Uncertainty ±				
In H2O	In H2O	In H2O	In H2O	In H2O	In H2O	In H2O	In H2O				
0.00	0.00	0.00	0.00	0.00	0.00	0.05	0.005				
0.50	0.50	0.50	0.00	0.50	0.00	0.05	0.005				
1.25	1.25	1.25	0.00	1.25	0.00	0.05	0.005				
2.50	2.50	2.50	0.00	2.50	0.00	0.05	0.006				
3.75	3.75	3.75	0.00	3.75	0.00	0.05	0.007				
5.00	5.00	5.00	0.00	5.00	0.00	0.05	0.008				
3.75	3.75	3.75	0.00	3.75	0.00	0.05	0.007				
2.50	2.50	2.50	0.00	2.50	0.00	0.05	0.006				
1.25	1.25	1.25	0.00	1.25	0.00	0.05	0.005				
0.50	0.50	0.50	0.00	0.50	0.00	0.05	0.005				
0.00	0.00	0.00	0.00	0.00	0.00	0.05	0.005				

Manufacturer: Newport

Type: Pressure Transducer

Serial #: Unknown

Remarks:

**We sincerely thank you for your business. Please call us at 503-654-9620 for all your sales and calibration needs.
Cleaning and preventative maintenance were performed as part of this service.**

**Cal-Cert is accredited by A2LA under Calibration Laboratory Code #4986.01.
A2LA is recognized under the ILAC mutual recognition agreement (MRA).**

This certificate is hereby issued that the above instrument was tested for accuracy with calibrated standards traceable to the National Institute of Standards and Technology (NIST). The information provided on this form complies with the data gathering and reporting requirements of ISO/IEC 17025 and ANSI/NCSS Z540.1, and meets the requirements of all applicable references and Cal-Cert procedures listed above. Any stated measurement uncertainty includes the uncertainty of the Calibration standards used, combined with the uncertainty of the measurement process using the RSS method with a k=2 for an approximate 95% level of confidence. The calibration process meets or exceeds a ratio of 4:1 unless otherwise stated.

All tolerances were derived from the applicable standards and pass/fail determination is based on those tolerances. The customer determined any recommended due dates indicated on the certificate.

This report shall not be reproduced except in full, without written approval from Cal-Cert.

Service Engineer:

Jon Rau

Date:

March 1, 2023

Technical Manager:

Marshall Doyle

Signature:



Report and Certificate of Calibration



www.Cal-Cert.com



Toll Free
800-356-4662

Address
5777 SE International Way
Milwaukie, OR 97222

Local
503-654-9620

Report #: 28140-203324-14 **Customer PO#:** 1090
Customer Name: PFS TECO
Customer Address: 11785 SE Highway 212 Ste 305
City: Clackamas **State:** OR **Zip:** 97015
Contact: Aaron Kravitz
Service Address: 11785 SE Highway 212 Ste 305 Clackamas, OR 97015

Calibration Standards

19-00269 Thermo-Hygrometer Comark SN: 6237360167 Cal: 09/14/2022 Due: 08/31/2023 Vendor: Cal-Cert Range: 122 °F 95 %RH Report #: 25699-30694-3486
LA-01776 Pressure Transducer Fluke SN: 5956001 Cal: 11/25/2022 Due: 11/25/2023 Range: 10 in H2O Report #: EVL846346

Instrument Data

Calibration Date:	March 1, 2023	Reference:	ASME B40.100
Recommended Due Date:	March 1, 2024	Cal-Cert Procedure:	CP-003
Calibration Frequency:	12 Months	Indicating System:	Digital
Manufacturer:	Newport	Temperature:	73 °F
Type:	Pressure Transducer	Humidity:	30% RH
Model Number:	Unknown	Cal Factor:	None
Serial #:	Unknown	Asset #:	53C
Capacity:	5 In H2O	Service Location:	Service Address
Tolerance:	± 1.00% of Span	As Found:	Pass
Gauge Class:	A	As Left:	Pass

Instrument Range:		5.00		Range Resolution:		0.01		Mode Verified:		Pressure	
UUT Reading	Standard As Found	Standard Verification Reading #1	Error	Standard Verification Reading #2	Error	Tolerance	Expanded Uncertainty ±				
In H2O	In H2O	In H2O	In H2O	In H2O	In H2O	In H2O	In H2O				
0.00	0.00	0.00	0.00	0.00	0.00	0.05	0.005				
0.50	0.50	0.50	0.00	0.50	0.00	0.05	0.005				
1.25	1.25	1.25	0.00	1.25	0.00	0.05	0.005				
2.50	2.50	2.50	0.00	2.50	0.00	0.05	0.006				
3.75	3.75	3.75	0.00	3.75	0.00	0.05	0.007				
5.00	5.00	5.00	0.00	5.00	0.00	0.05	0.008				
3.75	3.75	3.75	0.00	3.75	0.00	0.05	0.007				
2.50	2.50	2.50	0.00	2.50	0.00	0.05	0.006				
1.25	1.25	1.25	0.00	1.25	0.00	0.05	0.005				
0.50	0.50	0.50	0.00	0.50	0.00	0.05	0.005				
0.00	0.00	0.00	0.00	0.00	0.00	0.05	0.005				

Manufacturer: Newport

Type: Pressure Transducer

Serial #: Unknown

Remarks:

**We sincerely thank you for your business. Please call us at 503-654-9620 for all your sales and calibration needs.
Cleaning and preventative maintenance were performed as part of this service.**

**Cal-Cert is accredited by A2LA under Calibration Laboratory Code #4986.01.
A2LA is recognized under the ILAC mutual recognition agreement (MRA).**

This certificate is hereby issued that the above instrument was tested for accuracy with calibrated standards traceable to the National Institute of Standards and Technology (NIST). The information provided on this form complies with the data gathering and reporting requirements of ISO/IEC 17025 and ANSI/NCSS Z540.1, and meets the requirements of all applicable references and Cal-Cert procedures listed above. Any stated measurement uncertainty includes the uncertainty of the Calibration standards used, combined with the uncertainty of the measurement process using the RSS method with a k=2 for an approximate 95% level of confidence. The calibration process meets or exceeds a ratio of 4:1 unless otherwise stated.

All tolerances were derived from the applicable standards and pass/fail determination is based on those tolerances. The customer determined any recommended due dates indicated on the certificate.

This report shall not be reproduced except in full, without written approval from Cal-Cert.

Service Engineer:

Jon Rau

Date:

March 1, 2023

Technical Manager:

Marshall Doyle

Signature:



Report and Certificate of Calibration



www.Cal-Cert.com



Toll Free
800-356-4662

Address
5777 SE International Way
Milwaukie, OR 97222

Local
503-654-9620

Report #: 28134-206391-14 **Customer PO#:** 1090
Customer Name: PFS TECO
Customer Address: 11785 SE Highway 212 Ste 305
City: Clackamas **State:** OR **Zip:** 97015
Contact: Aaron Kravitz
Service Address: 11785 SE Highway 212 Ste 305 Clackamas, OR 97015

Calibration Standards

19-00269 Thermo-Hygrometer Comark SN: 6237360167 Cal: 09/14/2022 Due: 08/31/2023 Vendor: Cal-Cert Range: 122 °F 95 %RH Report #: 25699-30694-3486
19-01135 Thermocouple Meter Tegam SN: T-312250 Cal: 08/01/2022 Due: 08/31/2023 Vendor: Cal-Cert Range: 2,450 °F Report #: 25315-30977-3646

Instrument Data

Calibration Date:	February 28, 2023	Reference:	NAVAIR 17-20.ST-95
Recommended Due Date:	February 28, 2024	Cal-Cert Procedure:	CP-013
Calibration Frequency:	12 Months	Indicating System:	Digital
Manufacturer:	National Instruments	Temperature:	70 °F
Type:	Data Logger	Humidity:	31% RH
Model Number:	NI 9213	Asset #:	215 Booth 1
Serial #:	1B182FB	Service Location:	Service Address
Resolution:	0.1 °F	As Found:	Pass
Capacity:	2500 °F	As Left:	Pass
Tolerance:	± 3.0 °F		
Additional Error	± - °F		

Type K Thermocouple METER FUNCTION

Channel	Calibration Standard	UUT As Found	UUT As Left Reading 1	UUT As Left Reading 2	As Left Error	Expanded Uncertainty±
Tunnel	0.00	0.20	0.20	0.20	0.20	0.346
	500.00	500.30	500.30	500.30	0.30	
	1000.00	1000.40	1000.40	1000.40	0.40	
	1500.00	1500.40	1500.40	1500.40	0.40	
	2000.00	2000.50	2000.50	2000.50	0.50	
	2400.00	2400.70	2400.70	2400.70	0.70	

Type K Thermocouple METER FUNCTION

Channel	Calibration Standard	UUT As Found	UUT As Left Reading 1	UUT As Left Reading 2	As Left Error	Expanded Uncertainty±
Flue	0.00	0.10	0.10	0.10	0.10	0.346
	500.00	500.30	500.30	500.30	0.30	
	1000.00	1000.30	1000.30	1000.30	0.30	
	1500.00	1500.30	1500.30	1500.30	0.30	
	2000.00	2000.50	2000.50	2000.50	0.50	
	2400.00	2400.60	2400.60	2400.60	0.60	

Type K Thermocouple METER FUNCTION						
Channel	Calibration Standard	UUT As Found	UUT As Left Reading 1	UUT As Left Reading 2	As Left Error	Expanded Uncertainty±
Filter A	0.00	0.10	0.10	0.10	0.10	0.346
	500.00	500.10	500.10	500.10	0.10	
	1000.00	1000.20	1000.20	1000.20	0.20	
	1500.00	1500.30	1500.30	1500.30	0.30	
	2000.00	2000.30	2000.30	2000.30	0.30	
	2400.00	2400.40	2400.40	2400.40	0.40	

Type K Thermocouple METER FUNCTION						
Channel	Calibration Standard	UUT As Found	UUT As Left Reading 1	UUT As Left Reading 2	As Left Error	Expanded Uncertainty±
Back	0.00	0.10	0.10	0.10	0.10	0.346
	500.00	500.00	500.00	500.00	0.00	
	1000.00	1000.20	1000.20	1000.20	0.20	
	1500.00	1500.50	1500.50	1500.50	0.50	
	2000.00	2000.60	2000.60	2000.60	0.60	
	2400.00	2400.70	2400.70	2400.70	0.70	

Type K Thermocouple METER FUNCTION						
Channel	Calibration Standard	UUT As Found	UUT As Left Reading 1	UUT As Left Reading 2	As Left Error	Expanded Uncertainty±
Catgalyst	0.00	-0.30	-0.30	-0.30	-0.30	0.346
	500.00	499.90	499.90	499.90	-0.10	
	1000.00	1000.10	1000.10	1000.10	0.10	
	1500.00	1500.10	1500.10	1500.10	0.10	
	2000.00	2000.10	2000.10	2000.10	0.10	
	2400.00	2400.20	2400.20	2400.20	0.20	

Type K Thermocouple METER FUNCTION						
Channel	Calibration Standard	UUT As Found	UUT As Left Reading 1	UUT As Left Reading 2	As Left Error	Expanded Uncertainty±
Meter A	0.00	-0.50	-0.50	-0.50	-0.50	0.346
	500.00	499.70	499.70	499.70	-0.30	
	1000.00	999.90	999.90	999.90	-0.10	
	1500.00	1500.00	1500.00	1500.00	0.00	
	2000.00	2000.00	2000.00	2000.00	0.00	
	2400.00	2400.00	2400.00	2400.00	0.00	

Type K Thermocouple METER FUNCTION						
Channel	Calibration Standard	UUT As Found	UUT As Left Reading 1	UUT As Left Reading 2	As Left Error	Expanded Uncertainty±
Left	0.00	-0.50	-0.50	-0.50	-0.50	0.346
	500.00	499.70	499.70	499.70	-0.30	
	1000.00	999.70	999.70	999.70	-0.30	
	1500.00	1500.00	1500.00	1500.00	0.00	
	2000.00	2000.10	2000.10	2000.10	0.10	
	2400.00	2400.20	2400.20	2400.20	0.20	

Type K Thermocouple METER FUNCTION						
Channel	Calibration Standard	UUT As Found	UUT As Left Reading 1	UUT As Left Reading 2	As Left Error	Expanded Uncertainty±
Right	0.00	-0.60	-0.60	-0.60	-0.60	0.346
	500.00	499.70	499.70	499.70	-0.30	
	1000.00	999.80	999.80	999.80	-0.20	
	1500.00	1499.80	1499.80	1499.80	-0.20	
	2000.00	1999.90	1999.90	1999.90	-0.10	
	2400.00	2400.00	2400.00	2400.00	0.00	

Type K Thermocouple METER FUNCTION						
Channel	Calibration Standard	UUT As Found	UUT As Left Reading 1	UUT As Left Reading 2	As Left Error	Expanded Uncertainty±
Filter B	0.00	0.00	0.00	0.00	0.00	0.346
	500.00	500.80	500.80	500.80	0.80	
	1000.00	1000.60	1000.60	1000.60	0.60	
	1500.00	1500.20	1500.20	1500.20	0.20	
	2000.00	2000.00	2000.00	2000.00	0.00	
	2400.00	2399.70	2399.70	2399.70	-0.30	

Type K Thermocouple METER FUNCTION						
Channel	Calibration Standard	UUT As Found	UUT As Left Reading 1	UUT As Left Reading 2	As Left Error	Expanded Uncertainty±
Top	0.00	-0.80	-0.80	-0.80	-0.80	0.346
	500.00	499.30	499.30	499.30	-0.70	
	1000.00	999.50	999.50	999.50	-0.50	
	1500.00	1499.60	1499.60	1499.60	-0.40	
	2000.00	1999.60	1999.60	1999.60	-0.40	
	2400.00	2399.70	2399.70	2399.70	-0.30	

Type K Thermocouple METER FUNCTION						
Channel	Calibration Standard	UUT As Found	UUT As Left Reading 1	UUT As Left Reading 2	As Left Error	Expanded Uncertainty±
Bottom	0.00	-1.00	-1.00	-1.00	-1.00	0.346
	500.00	499.20	499.20	499.20	-0.80	
	1000.00	999.50	999.50	999.50	-0.50	
	1500.00	1499.50	1499.50	1499.50	-0.50	
	2000.00	1999.60	1999.60	1999.60	-0.40	
	2400.00	2399.60	2399.60	2399.60	-0.40	

Type K Thermocouple METER FUNCTION						
Channel	Calibration Standard	UUT As Found	UUT As Left Reading 1	UUT As Left Reading 2	As Left Error	Expanded Uncertainty±
Meter B	0.00	-0.80	-0.80	-0.80	-0.80	0.346
	500.00	499.30	499.30	499.30	-0.70	
	1000.00	999.50	999.50	999.50	-0.50	
	1500.00	1499.50	1499.50	1499.50	-0.50	
	2000.00	1999.60	1999.60	1999.60	-0.40	
	2400.00	2399.50	2399.50	2399.50	-0.50	

Type K Thermocouple METER FUNCTION						
Channel	Calibration Standard	UUT As Found	UUT As Left Reading 1	UUT As Left Reading 2	As Left Error	Expanded Uncertainty±
Meter C	0.00	-1.20	-1.20	-1.20	-1.20	0.346
	500.00	499.00	499.00	499.00	-1.00	
	1000.00	999.20	999.20	999.20	-0.80	
	1500.00	1499.30	1499.30	1499.30	-0.70	
	2000.00	1999.30	1999.30	1999.30	-0.70	
	2400.00	2399.30	2399.30	2399.30	-0.70	

Type K Thermocouple METER FUNCTION						
Channel	Calibration Standard	UUT As Found	UUT As Left Reading 1	UUT As Left Reading 2	As Left Error	Expanded Uncertainty±
Filter C	0.00	-1.00	-1.00	-1.00	-1.00	0.346
	500.00	499.20	499.20	499.20	-0.80	
	1000.00	999.40	999.40	999.40	-0.60	
	1500.00	1499.50	1499.50	1499.50	-0.50	
	2000.00	1999.50	1999.50	1999.50	-0.50	
	2400.00	2399.50	2399.50	2399.50	-0.50	

Manufacturer: National Instruments

Type: Data Logger

Serial #: 1B182FB

Type T Thermocouple METER FUNCTION						
Channel	Calibration Standard	UUT As Found	UUT As Left Reading 1	UUT As Left Reading 2	As Left Error	Expanded Uncertainty±
Ambient	0.00	0.00	0.00	0.00	0.00	0.346
	20.00	17.70	17.70	17.70	-2.30	
	40.00	37.80	37.80	37.80	-2.20	
	60.00	57.70	57.70	57.70	-2.30	
	80.00	77.90	77.90	77.90	-2.10	
	100.00	97.90	97.90	97.90	-2.10	

Remarks:

15 Channels tested. Ambient is Type T, tested from 0 to 100 °F per customer request.

We sincerely thank you for your business. Please call us at 503-654-9620 for all your sales and calibration needs. Cleaning and preventative maintenance were performed as part of this service.

Cal-Cert is accredited by A2LA under Calibration Laboratory Code #4986.01. A2LA is recognized under the ILAC mutual recognition agreement (MRA).

This certificate is hereby issued that the above instrument was tested for accuracy with calibrated standards traceable to the National Institute of Standards and Technology (NIST). The information provided on this form complies with the data gathering and reporting requirements of ISO/IEC 17025 and ANSI/NCSL Z540.1, and meets the requirements of all applicable references and Cal-Cert procedures listed above. Any stated measurement uncertainty includes the uncertainty of the Calibration standards used, combined with the uncertainty of the measurement process using the RSS method with a k=2 for an approximate 95% level of confidence. The calibration process meets or exceeds a ratio of 4:1 unless otherwise stated. All tolerances were derived from the applicable standards and pass/fail determination is based on those tolerances. The customer determined any recommended due dates indicated on the certificate.

This report shall not be reproduced except in full, without written approval from Cal-Cert.

Service Engineer: Jon Rau

Date: February 28, 2023

Technical Manager Marshall Doyle

Signature: *M Doyle*

Report and Certificate of Calibration



www.Cal-Cert.com



Toll Free
800-356-4662

Address
5777 SE International Way
Milwaukie, OR 97222

Local
503-654-9620

Report #: 28134-206391-14 **Customer PO#:** 1090
Customer Name: PFS TECO
Customer Address: 11785 SE Highway 212 Ste 305
City: Clackamas **State:** OR **Zip:** 97015
Contact: Aaron Kravitz
Service Address: 11785 SE Highway 212 Ste 305 Clackamas, OR 97015

Calibration Standards

19-00269 Thermo-Hygrometer Comark SN: 6237360167 Cal: 09/14/2022 Due: 08/31/2023 Vendor: Cal-Cert Range: 122 °F 95 %RH Report #: 25699-30694-3486
19-01135 Thermocouple Meter Tegam SN: T-312250 Cal: 08/01/2022 Due: 08/31/2023 Vendor: Cal-Cert Range: 2,450 °F Report #: 25315-30977-3646

Instrument Data

Calibration Date:	February 28, 2023	Reference:	NAVAIR 17-20.ST-95
Recommended Due Date:	February 28, 2024	Cal-Cert Procedure:	CP-013
Calibration Frequency:	12 Months	Indicating System:	Digital
Manufacturer:	National Instruments	Temperature:	72 °F
Type:	Data Logger	Humidity:	30% RH
Model Number:	NI 9213	Asset #:	215 Booth 1
Serial #:	1B182FB	Service Location:	Service Address
Resolution:	0.1 °F	As Found:	Pass
Capacity:	2500 °F	As Left:	Pass
Tolerance:	± 2.0 °F		
Additional Error	± - °F		

Type K Thermocouple METER FUNCTION

Channel	Calibration Standard	UUT As Found	UUT As Left Reading 1	UUT As Left Reading 2	As Left Error	Expanded Uncertainty±
Tunnel	0.00	-0.20	-0.20	-0.20	-0.20	0.346
	500.00	499.80	499.80	499.80	-0.20	
	1000.00	1000.00	1000.00	1000.00	0.00	
	1500.00	1500.10	1500.10	1500.10	0.10	
	2000.00	2000.10	2000.10	2000.10	0.10	
	2400.00	2400.10	2400.10	2400.10	0.10	

Type K Thermocouple METER FUNCTION

Channel	Calibration Standard	UUT As Found	UUT As Left Reading 1	UUT As Left Reading 2	As Left Error	Expanded Uncertainty±
Flue	0.00	-0.40	-0.40	-0.40	-0.40	0.346
	500.00	499.60	499.60	499.60	-0.40	
	1000.00	999.70	999.70	999.70	-0.30	
	1500.00	1499.90	1499.90	1499.90	-0.10	
	2000.00	1999.80	1999.80	1999.80	-0.20	
	2400.00	2400.00	2400.00	2400.00	0.00	

Type K Thermocouple METER FUNCTION						
Channel	Calibration Standard	UUT As Found	UUT As Left Reading 1	UUT As Left Reading 2	As Left Error	Expanded Uncertainty±
Filter A	0.00	-0.60	-0.60	-0.60	-0.60	0.346
	500.00	499.50	499.50	499.50	-0.50	
	1000.00	999.60	999.60	999.60	-0.40	
	1500.00	1499.70	1499.70	1499.70	-0.30	
	2000.00	1999.80	1999.80	1999.80	-0.20	
	2400.00	2399.80	2399.80	2399.80	-0.20	

Type K Thermocouple METER FUNCTION						
Channel	Calibration Standard	UUT As Found	UUT As Left Reading 1	UUT As Left Reading 2	As Left Error	Expanded Uncertainty±
Back	0.00	-0.70	-0.70	-0.70	-0.70	0.346
	500.00	499.50	499.50	499.50	-0.50	
	1000.00	999.50	999.50	999.50	-0.50	
	1500.00	1499.60	1499.60	1499.60	-0.40	
	2000.00	1999.70	1999.70	1999.70	-0.30	
	2400.00	2399.60	2399.60	2399.60	-0.40	

Type K Thermocouple METER FUNCTION						
Channel	Calibration Standard	UUT As Found	UUT As Left Reading 1	UUT As Left Reading 2	As Left Error	Expanded Uncertainty±
Catgalyst	0.00	-0.70	-0.70	-0.70	-0.70	0.346
	500.00	499.40	499.40	499.40	-0.60	
	1000.00	999.60	999.60	999.60	-0.40	
	1500.00	1499.60	1499.60	1499.60	-0.40	
	2000.00	1999.70	1999.70	1999.70	-0.30	
	2400.00	2399.70	2399.70	2399.70	-0.30	

Type K Thermocouple METER FUNCTION						
Channel	Calibration Standard	UUT As Found	UUT As Left Reading 1	UUT As Left Reading 2	As Left Error	Expanded Uncertainty±
Meter A	0.00	-1.30	-1.30	-1.30	-1.30	0.346
	500.00	498.80	498.80	498.80	-1.20	
	1000.00	999.10	999.10	999.10	-0.90	
	1500.00	1499.10	1499.10	1499.10	-0.90	
	2000.00	1999.10	1999.10	1999.10	-0.90	
	2400.00	2399.10	2399.10	2399.10	-0.90	

Type K Thermocouple METER FUNCTION						
Channel	Calibration Standard	UUT As Found	UUT As Left Reading 1	UUT As Left Reading 2	As Left Error	Expanded Uncertainty±
Left	0.00	-1.30	-1.30	-1.30	-1.30	0.346
	500.00	498.90	498.90	498.90	-1.10	
	1000.00	999.00	999.00	999.00	-1.00	
	1500.00	1499.20	1499.20	1499.20	-0.80	
	2000.00	1999.20	1999.20	1999.20	-0.80	
	2400.00	2399.20	2399.20	2399.20	-0.80	

Type K Thermocouple METER FUNCTION						
Channel	Calibration Standard	UUT As Found	UUT As Left Reading 1	UUT As Left Reading 2	As Left Error	Expanded Uncertainty±
Right	0.00	-1.40	-1.40	-1.40	-1.40	0.346
	500.00	498.90	498.90	498.90	-1.10	
	1000.00	999.00	999.00	999.00	-1.00	
	1500.00	1499.00	1499.00	1499.00	-1.00	
	2000.00	1999.00	1999.00	1999.00	-1.00	
	2400.00	2399.10	2399.10	2399.10	-0.90	

Type K Thermocouple METER FUNCTION						
Channel	Calibration Standard	UUT As Found	UUT As Left Reading 1	UUT As Left Reading 2	As Left Error	Expanded Uncertainty±
Filter B	0.00	0.00	0.00	0.00	0.00	0.346
	500.00	500.60	500.60	500.60	0.60	
	1000.00	1000.30	1000.30	1000.30	0.30	
	1500.00	1500.10	1500.10	1500.10	0.10	
	2000.00	1999.80	1999.80	1999.80	-0.20	
	2400.00	2399.50	2399.50	2399.50	-0.50	

Type K Thermocouple METER FUNCTION						
Channel	Calibration Standard	UUT As Found	UUT As Left Reading 1	UUT As Left Reading 2	As Left Error	Expanded Uncertainty±
Top	0.00	-1.40	-1.40	-1.40	-1.40	0.346
	500.00	498.90	498.90	498.90	-1.10	
	1000.00	999.00	999.00	999.00	-1.00	
	1500.00	1499.10	1499.10	1499.10	-0.90	
	2000.00	1999.00	1999.00	1999.00	-1.00	
	2400.00	2399.00	2399.00	2399.00	-1.00	

Type K Thermocouple METER FUNCTION						
Channel	Calibration Standard	UUT As Found	UUT As Left Reading 1	UUT As Left Reading 2	As Left Error	Expanded Uncertainty±
Bottom	0.00	-1.50	-1.50	-1.50	-1.50	0.346
	500.00	498.80	498.80	498.80	-1.20	
	1000.00	999.00	999.00	999.00	-1.00	
	1500.00	1499.00	1499.00	1499.00	-1.00	
	2000.00	1999.00	1999.00	1999.00	-1.00	
	2400.00	2399.00	2399.00	2399.00	-1.00	

Type K Thermocouple METER FUNCTION						
Channel	Calibration Standard	UUT As Found	UUT As Left Reading 1	UUT As Left Reading 2	As Left Error	Expanded Uncertainty±
Meter B	0.00	-1.30	-1.30	-1.30	-1.30	0.346
	500.00	499.00	499.00	499.00	-1.00	
	1000.00	999.00	999.00	999.00	-1.00	
	1500.00	1499.20	1499.20	1499.20	-0.80	
	2000.00	1999.20	1999.20	1999.20	-0.80	
	2400.00	2399.10	2399.10	2399.10	-0.90	

Type K Thermocouple METER FUNCTION						
Channel	Calibration Standard	UUT As Found	UUT As Left Reading 1	UUT As Left Reading 2	As Left Error	Expanded Uncertainty±
Meter C	0.00	-1.20	-1.20	-1.20	-1.20	0.346
	500.00	498.90	498.90	498.90	-1.10	
	1000.00	999.10	999.10	999.10	-0.90	
	1500.00	1499.20	1499.20	1499.20	-0.80	
	2000.00	1999.20	1999.20	1999.20	-0.80	
	2400.00	2399.20	2399.20	2399.20	-0.80	

Type K Thermocouple METER FUNCTION						
Channel	Calibration Standard	UUT As Found	UUT As Left Reading 1	UUT As Left Reading 2	As Left Error	Expanded Uncertainty±
Filter C	0.00	-1.20	-1.20	-1.20	-1.20	0.346
	500.00	499.10	499.10	499.10	-0.90	
	1000.00	999.20	999.20	999.20	-0.80	
	1500.00	1499.30	1499.30	1499.30	-0.70	
	2000.00	1999.30	1999.30	1999.30	-0.70	
	2400.00	2399.20	2399.20	2399.20	-0.80	

Manufacturer: National Instruments

Type: Data Logger

Serial #: 1B182FB

Type T Thermocouple METER FUNCTION						
Channel	Calibration Standard	UUT As Found	UUT As Left Reading 1	UUT As Left Reading 2	As Left Error	Expanded Uncertainty±
Ambient	0.00	-1.40	-1.40	-1.40	-1.40	0.346
	20.00	18.80	18.80	18.80	-1.20	
	40.00	38.80	38.80	38.80	-1.20	
	60.00	58.70	58.70	58.70	-1.30	
	80.00	78.80	78.80	78.80	-1.20	
	100.00	98.70	98.70	98.70	-1.30	

Remarks:

15 Channels tested. Ambient is Type T, tested from 0 to 100 °F per customer request.

We sincerely thank you for your business. Please call us at 503-654-9620 for all your sales and calibration needs. Cleaning and preventative maintenance were performed as part of this service.

Cal-Cert is accredited by A2LA under Calibration Laboratory Code #4986.01. A2LA is recognized under the ILAC mutual recognition agreement (MRA).

This certificate is hereby issued that the above instrument was tested for accuracy with calibrated standards traceable to the National Institute of Standards and Technology (NIST). The information provided on this form complies with the data gathering and reporting requirements of ISO/IEC 17025 and ANSI/NC SL Z540.1, and meets the requirements of all applicable references and Cal-Cert procedures listed above. Any stated measurement uncertainty includes the uncertainty of the Calibration standards used, combined with the uncertainty of the measurement process using the RSS method with a k=2 for an approximate 95% level of confidence. The calibration process meets or exceeds a ratio of 4:1 unless otherwise stated. All tolerances were derived from the applicable standards and pass/fail determination is based on those tolerances. The customer determined any recommended due dates indicated on the certificate.

This report shall not be reproduced except in full, without written approval from Cal-Cert.

Service Engineer: Jon Rau

Date: February 28, 2023

Technical Manager: Marshall Doyle

Signature: 

Report and Certificate of Calibration



www.Cal-Cert.com

Toll Free
800-356-4662

Address
5777 SE International Way
Milwaukie, OR 97222

Local
503-654-9620



Report #: 28140-203320-14 **Customer PO#:** 1090
Customer Name: PFS TECO
Customer Address: 11785 SE Highway 212 Ste 305
City: Clackamas **State:** OR **Zip:** 97015
Contact: Aaron Kravitz
Service Address: 11785 SE Highway 212 Ste 305 Clackamas, OR 97015

Calibration Standards

19-00269 Thermo-Hygrometer Comark SN: 6237360167 Cal: 09/14/2022 Due: 08/31/2023 Vendor: Cal-Cert Range: 122 °F 95 %RH Report #: 25699-30694-3486
LA-01776 Pressure Transducer Fluke SN: 5956001 Cal: 11/25/2022 Due: 11/25/2023 Range: 10 in H2O Report #: EVL846346

Instrument Data

Calibration Date:	March 1, 2023	Reference:	ASME B40.100
Recommended Due Date:	March 1, 2024	Cal-Cert Procedure:	CP-003
Calibration Frequency:	12 Months	Indicating System:	Digital
Manufacturer:	Red Lion	Temperature:	73 °F
Type:	Pressure Transducer	Humidity:	30% RH
Model Number:	Unknown	Cal Factor:	None
Serial #:	Unknown	Asset #:	203C
Capacity:	5 In H2O	Service Location:	Service Address
Tolerance:	± 1.00% of Span	As Found:	Pass
Gauge Class:	A	As Left:	Pass

Instrument Range:		5.00		Range Resolution:		0.01		Mode Verified:		Pressure	
UUT Reading	Standard As Found	Standard Verification Reading #1	Error	Standard Verification Reading #2	Error	Tolerance	Expanded Uncertainty ±				
In H2O	In H2O	In H2O	In H2O	In H2O	In H2O	In H2O	In H2O				
0.00	0.00	0.00	0.00	0.00	0.00	0.05	0.005				
0.50	0.50	0.50	0.00	0.50	0.00	0.05	0.005				
1.25	1.25	1.25	0.00	1.25	0.00	0.05	0.005				
2.50	2.50	2.50	0.00	2.50	0.00	0.05	0.006				
3.75	3.75	3.75	0.00	3.75	0.00	0.05	0.007				
5.00	5.00	5.00	0.00	5.00	0.00	0.05	0.008				
3.75	3.75	3.75	0.00	3.75	0.00	0.05	0.007				
2.50	2.50	2.50	0.00	2.50	0.00	0.05	0.006				
1.25	1.25	1.25	0.00	1.25	0.00	0.05	0.005				
0.50	0.50	0.50	0.00	0.50	0.00	0.05	0.005				
0.00	0.00	0.00	0.00	0.00	0.00	0.05	0.005				

Manufacturer: Red Lion

Type: Pressure Transducer

Serial #: Unknown

Remarks:

**We sincerely thank you for your business. Please call us at 503-654-9620 for all your sales and calibration needs.
Cleaning and preventative maintenance were performed as part of this service.**

**Cal-Cert is accredited by A2LA under Calibration Laboratory Code #4986.01.
A2LA is recognized under the ILAC mutual recognition agreement (MRA).**

This certificate is hereby issued that the above instrument was tested for accuracy with calibrated standards traceable to the National Institute of Standards and Technology (NIST). The information provided on this form complies with the data gathering and reporting requirements of ISO/IEC 17025 and ANSI/NCSS Z540.1, and meets the requirements of all applicable references and Cal-Cert procedures listed above. Any stated measurement uncertainty includes the uncertainty of the Calibration standards used, combined with the uncertainty of the measurement process using the RSS method with a k=2 for an approximate 95% level of confidence. The calibration process meets or exceeds a ratio of 4:1 unless otherwise stated.

All tolerances were derived from the applicable standards and pass/fail determination is based on those tolerances. The customer determined any recommended due dates indicated on the certificate.

This report shall not be reproduced except in full, without written approval from Cal-Cert.

Service Engineer:

Jon Rau

Date:

March 1, 2023

Technical Manager:

Marshall Doyle

Signature:



Report and Certificate of Calibration



www.Cal-Cert.com



Toll Free
800-356-4662

Address
5777 SE International Way
Milwaukie, OR 97222

Local
503-654-9620

Report #: 28140-203319-14 **Customer PO#:** 1090
Customer Name: PFS TECO
Customer Address: 11785 SE Highway 212 Ste 305
City: Clackamas **State:** OR **Zip:** 97015
Contact: Aaron Kravitz
Service Address: 11785 SE Highway 212 Ste 305 Clackamas, OR 97015

Calibration Standards

19-00269 Thermo-Hygrometer Comark SN: 6237360167 Cal: 09/14/2022 Due: 08/31/2023 Vendor: Cal-Cert Range: 122 °F 95 %RH Report #: 25699-30694-3486
LA-01776 Pressure Transducer Fluke SN: 5956001 Cal: 11/25/2022 Due: 11/25/2023 Range: 10 in H2O Report #: EVL846346

Instrument Data

Calibration Date:	March 1, 2023	Reference:	ASME B40.100
Recommended Due Date:	March 1, 2024	Cal-Cert Procedure:	CP-003
Calibration Frequency:	12 Months	Indicating System:	Digital
Manufacturer:	Red Lion	Temperature:	69 °F
Type:	Pressure Transducer	Humidity:	35% RH
Model Number:	Unknown	Cal Factor:	None
Serial #:	Unknown	Asset #:	203B
Capacity:	1 In H2O	Service Location:	Service Address
Tolerance:	± 1.00% of Span	As Found:	Pass
Gauge Class:	A	As Left:	Pass

Instrument Range: 1.00		Range Resolution: 0.001		Mode Verified: Pressure			
UUT Reading	Standard As Found	Standard Verification Reading #1	Error	Standard Verification Reading #2	Error	Tolerance	Expanded Uncertainty ±
In H2O	In H2O	In H2O	In H2O	In H2O	In H2O	In H2O	In H2O
0.000	0.000	0.000	0.00	0.000	0.00	0.01	0.0005
0.100	0.100	0.100	0.00	0.100	0.00	0.01	0.0005
0.250	0.250	0.250	0.00	0.250	0.00	0.01	0.0006
0.500	0.500	0.500	0.00	0.500	0.00	0.01	0.0008
0.750	0.750	0.750	0.00	0.750	0.00	0.01	0.001
1.000	1.000	1.000	0.00	1.000	0.00	0.01	0.0012
0.750	0.750	0.750	0.00	0.750	0.00	0.01	0.001
0.500	0.500	0.500	0.00	0.500	0.00	0.01	0.0008
0.250	0.250	0.250	0.00	0.250	0.00	0.01	0.0006
0.100	0.100	0.100	0.00	0.100	0.00	0.01	0.0005
0.000	0.000	0.000	0.00	0.000	0.00	0.01	0.0005

Manufacturer: Red Lion

Type: Pressure Transducer

Serial #: Unknown

Remarks:

**We sincerely thank you for your business. Please call us at 503-654-9620 for all your sales and calibration needs.
Cleaning and preventative maintenance were performed as part of this service.**

**Cal-Cert is accredited by A2LA under Calibration Laboratory Code #4986.01.
A2LA is recognized under the ILAC mutual recognition agreement (MRA).**

This certificate is hereby issued that the above instrument was tested for accuracy with calibrated standards traceable to the National Institute of Standards and Technology (NIST). The information provided on this form complies with the data gathering and reporting requirements of ISO/IEC 17025 and ANSI/NCSS Z540.1, and meets the requirements of all applicable references and Cal-Cert procedures listed above. Any stated measurement uncertainty includes the uncertainty of the Calibration standards used, combined with the uncertainty of the measurement process using the RSS method with a k=2 for an approximate 95% level of confidence. The calibration process meets or exceeds a ratio of 4:1 unless otherwise stated.

All tolerances were derived from the applicable standards and pass/fail determination is based on those tolerances. The customer determined any recommended due dates indicated on the certificate.

This report shall not be reproduced except in full, without written approval from Cal-Cert.

Service Engineer:

Jon Rau

Date:

March 1, 2023

Technical Manager:

Marshall Doyle

Signature:



Certificate of Calibration

Certificate Number: 743892



JJ Calibrations, Inc.

7724 SE Aspen Summit Drive
Portland, OR 97266-9217
Phone 503.786.3005
FAX 503.786.2994

PFS TECO

11785 SE Hwy 212
Suite 305
Clackamas, OR 97015

PO: 1033

Order Date: 03/08/2021

Authorized By: N/A



Calibrated on: 03/18/2021

*Recommended Due: 03/18/2026

Environment: 19 °C 41 % RH

* As Received: Other - See Remarks

* As Returned: Other - See Remarks

Action Taken: Calibrated

Technician: 126

Property #: 097
User: N/A
Department: N/A
Make: Unknown
Model: 10 Lbs.
Serial #: 097
Description: Mass
Procedure: DCN 500901
Accuracy: Raw Data

Remarks: * Many factors may cause the unit to drift out of calibration before the recommended due date. Any reported error is the absolute value between the reference and the unit. Uncertainties include the effects of the unit.

Data is provided for your determination of acceptability. Received/returned without accessories.

Standards Used

Std ID	Manufacturer	Model	Nomenclature	Due Date	Trace ID
484A	Rice Lake	1kg-10kg (Class ASTM 1)	Mass Set,	05/28/2021	699197
503A	Rice Lake	1mg-200g (Class 0)	Mass Set,	09/11/2021	729241
550A	And (A&D) Co.	HP-30K	Balance 30 Kg	12/31/2021	739307
723A	Rice Lake	1mg-200g (Class 0)	Mass Set,	06/09/2021	723431

Measurement Data

Parameter	Measurement Description	Range	Unit	Reference	Min	Max	*Error	UUT	Uncertainty
Before/After									Accredited = \bar{U}
Mass									
	Raw Data		g	4535.92370000	0.0000000	0.0000000	0.1785299	4536.1022299 g	3.5E-01 \bar{U}

This instrument has been calibrated in accordance with the JJ Calibrations Quality Assurance Manual and is traceable to either the SI or to National Institute of Standards and Technology (NIST). The quality system and this certificate are in compliance with ANSI/NCSL Z540-1-1994, ISO/IEC 17025-2017, ISO 10012-1, the ISO 9000 family and QS 9000. The expanded uncertainties of measurements for this calibration are based upon 95% (2 sigma) confidence limits. Unless stated in the comments, certificates reflect the "Simple Acceptance Rule" as specified by JCGM 106:2012. Unless otherwise stated, a test accuracy ratio (TAR) of 4:1, if achievable, is maintained. The results reported herein apply only to the calibration of the item described above. This report may not be reproduced, except in full, without written approval of JJ Calibrations.

Reviewer

3 Issued 03/25/2021

Rev # 15

Inspector



CERTIFICATE OF CALIBRATION

CUSTOMER:	PFS-TECO : CLACKAMAS, OR	CALIBRATION DATE:	05/23/2023
PO NUMBER:	1097	CALIBRATION DUE:	05/23/2024
INST. MANUFACTURER:	DWYER	PROCEDURE:	T.O.33K6-4-1769-1
INST. DESCRIPTION:	VELOMETER	CALIBRATION FLUID:	AIR @ 14.7 PSIA 70°F
MODEL NUMBER:	471	RECEIVED CONDITION:	WITHIN MFG. SPECS.
SERIAL NUMBER:	CP288559 ID# 095	LEFT CONDITION:	WITHIN MFG. SPECS.
RATED ACCURACY:	SEE NOTES BELOW.	AMBIENT CONDITIONS:	763mm HGA 53% RH 71°F
UNCERTAINTY GIVEN:	± 0.43% RD ; k=2	CERTIFICATE FILE #:	490265.2023
NOTES:	± 3.0% FS (0-500 / 0-1500) ** ± 4.0% F.S. (0-5000) **± 5.0% F.S. (0-15000) ** ± 2 °F		

Q.MANUAL IM 2.0 REV 2020.2 DATED 7-27-2020

DECISION RULE: SIMPLE ACCEPTANCE. MEASUREMENT UNCERTAINTIES NOT TAKEN INTO CONSIDERATION WHEN DETERMINING PASS/FAIL

UUT INDICATED FT/MIN	DM.STD. ACTUAL FT/MIN	UUT INDICATED DEG. F	DM STD. ACTUAL DEG. F
74	77	0 TO 200°F	0 TO 200°F
118	121	45.0	44.5
253	259	73.9	73.2
491	502	100.3	99.8
515	525		
1028	1049		
1492	1526		
502	514		
3145	3224		
4993	5135		
6892	7061		
14821	15229		

STANDARDS USED:

A310: TEMP. STANDARD ± 0.024 F TRACE# 1649766843	DUE	02/09/2024
A800: FLOW-DYNE SONIC NOZZLE SYSTEM 0 - 1086 CFM ± 0.46% RD. TRACE# 144613547, 1424683640, 1583314714	DUE	12/10/2023

All instruments used in the performance of the shown calibration have traceability to the National Institute of Standards and Technology (NIST). The uncertainty ratio between the calibration standards (DM.STD.) and the Unit Under Test (UUT) is a minimum of 4:1, unless otherwise noted. Calibration has been performed according to the shown procedure. The use of IAS/ILAC logo indicates calibrations are in accordance to ISO/IEC 17025:2017.

Dick Munns Company · 11133 Winners Circle, Los Alamitos, CA 90720
Phone: 714-827-1215 · www.dickmunns.com

This Calibration Certificate shall not be reproduced except, in full, without approval by Dick Munns Company. The data shown applies only to the instrument being calibrated and under the stated conditions of calibration.

Issuing Date:

Approved By:

Cal. Technician:

Calibrated at: Lab

On-Site (Customer's)

5-23-2023

DC

Page 1 of 1



QUALITY CONTROL SERVICES

LABORATORY EQUIPMENT • SALES • SERVICE • CALIBRATION • REPAIRS
2340 SE 11TH Ave. Portland, Oregon 97214 • Box 14831 Portland, Oregon 97293
(503) 236-2712 • FAX (503) 235-2535 • www.qc-services.com



PFS Teco
11785 SE Hwy 212 STE#305
Clackamas, OR 97015

Report Number: DIRI01C101887027221214

A2LA ACCREDITED CERTIFICATE OF CALIBRATION WITH DATA

INSTRUMENT INFORMATION

Item	Make	Model	Serial Number	Customer ID	Location
Scale	Mettler	IND570 - 1000lhx0.	C101887027	#189	Lab
Units	Readability	SOP	Cal Date	Last Cal Date	Cal Due Date
lbs	0.02	QC033	12/14/22	1/27/22	12/2023

FUNCTIONAL CHECKS

SHIFT TEST		LINEARITY		REPEATABILITY		ENVIRONMENTAL CONDITIONS		
Test Wt:	Tol:	Test Wt:	Tol:	Test Wt:	Tol:			
400	0.10	HB44	HB44	200	0.04			
As-Found:		As-Found:		As-Found:				
Pass: <input checked="" type="checkbox"/>	Fail: <input type="checkbox"/>	Pass: <input checked="" type="checkbox"/>	Fail: <input type="checkbox"/>	Pass: <input checked="" type="checkbox"/>	Fail: <input type="checkbox"/>	<input type="checkbox"/> Good <input checked="" type="checkbox"/> Fair <input type="checkbox"/> Poor		
As-Left:		As-Left:		As-Left:		Temperature: 16.7°C		
Pass: <input checked="" type="checkbox"/>	Fail: <input type="checkbox"/>	Pass: <input checked="" type="checkbox"/>	Fail: <input type="checkbox"/>	Pass: <input checked="" type="checkbox"/>	Fail: <input type="checkbox"/>			

CALIBRATION DATA

Standard	As-Found	As-Left	Expanded Uncertainty
1000	1000.84	1000.02	0.012
600	600.32	600.00	0.011
400	400.10	400.00	0.011
200	200.00	199.98	0.011
100	100.00	99.98	0.011
50	50.00	50.00	0.011

CALIBRATION STANDARDS

Item	Make	Model	Serial Number	Cal Date	Cal Due Date	NIST ID
Avoirdupois Cast W	Rice Lake	25 and 50lb	PWO990-CA	7/18/22	7/2024	20221688

Permanent Information Concerning this Equipment:

Comments/Information Concerning this Calibration

12/14 As-Found Failed Linearity. Performed 3 point Linearity adjustment. As-Left Passed Linearity. Adjusted span.

Report prepared/reviewed by: JC

Date: 12/14/22

Technician: J. Colacchio

Signature: [Signature]

THIS CERTIFICATE SHALL NOT BE REPRODUCED, EXCEPT IN FULL, WITHOUT THE APPROVAL OF QUALITY CONTROL SERVICES, INC.

The uncertainty is calculated according to the ISO Guide to the Expression of Uncertainty in Measurement and includes the uncertainty of standards used combined with the observed standard deviation of the unit under test. The uncertainty is expanded with a k factor of 2 for an approximate 95% level of confidence. Instruments listed above were calibrated using standards traceable to the National Institute of Standards and Technology (NIST). Calibration data reflect results at the time and location of calibration. Calibration data should be reviewed to insure that the instrument is performing to its required accuracy.



QUALITY CONTROL SERVICES

LABORATORY EQUIPMENT • SALES • SERVICE • CALIBRATION • REPAIRS
2340 SE 11TH Ave. Portland, Oregon 97214 • Box 14831 Portland, Oregon 97293
(503) 236-2712 • FAX (503) 235-2535 • www.qc-services.com



Report of Calibration

Firm: PFS-TECO
Address: 11785 SE Hwy 212, Ste 305
City/State/Zip: Clackamas, OR 97015

Test Completed: 05/09/22
Purchase Order: 1067
Traceable Number: 20220682

Test Item: 200 mg and 100 mg Individual Weights
Serial No.: Listed in Table

Manufacturer: Troemner
Customer ID: Listed in Table

<u>Material</u>	<u>Assumed Density</u>	<u>Range</u>	<u>Tolerance Class</u>
Stainless Steel	7.95 g/cm ³	200 mg & 100 mg	ASTM Class 1

Method and Traceability

The procedure used for this calibration is NIST IR 6969 SOP 4 Double Substitution Weighing Design. Standards used for comparison are traceable to the National Institute of Standards and Technology (reports on file) and are part of a comprehensive measurement assurance program for ensuring continued accuracy and traceability within the level of uncertainty reported. The Traceable Number listed above is Traceable to National Standards through an unbroken chain of comparison each having stated uncertainties.

Standards Used:

100 g to 1 mg Working Standards Were Calibrated: 07/02/21 Due: 07/31/22 Standards ID: 723318
Mass Comparators Used: MET-05 Tested by: D. Thompson

Conventional Mass: “The conventional value of the result of weighing a body in air is equal to the mass of a standard, of conventionally chosen density, at a conventionally chosen temperature, which balances this body at this reference temperature in air of conventionally chosen density. International Recommendation 33 (OIML IR 33 1973, 1979). “Conventional Value of the Result of Weighing in Air” (Previously known as “Apparent Mass vs. 8.0 g/cm³).

Uncertainty Statement: The uncertainty conforms to the ISO Guide to the Expressions of Uncertainty in Measurement. Uncertainty as reported is based on a coverage factor $k=2$ for an approximate 95 percent level of uncertainty. Uncertainty components include the standard deviation of the process, the uncertainty of the standard used, an uncertainty component associated with the potential drift of the standard used, and the estimated uncertainty related to measuring and determining the air buoyancy effect.

Conventional Mass Values are listed on page 2 of this report.

page 1 of 2

Quality Control Services, Inc.
Metrology Laboratory Manager
E-mail dthompson@qc-services.com

Date: 05/09/22

Signature David S. Thompson

This document shall not be reproduced, except in full, without the written approval of Quality Control Services Mass Laboratory.

Member: National Conference of Standards Laboratories and Weights & Measures



QUALITY CONTROL SERVICES

LABORATORY EQUIPMENT • SALES • SERVICE • CALIBRATION • REPAIRS
2340 SE 11TH Ave. Portland, Oregon 97214 • Box 14831 Portland, Oregon 97293
(503) 236-2712 • FAX (503) 235-2535 • www.qc-services.com



Report of Calibration

Firm: PFS-TECO
Address: 11785 SE Hwy 212, Ste 305
City/State/Zip: Clackamas, OR 97015

Test Completed: 05/09/22
Purchase Order: 1067
Traceable Number: 20220682

Test Item: 200 mg and 100 mg Individual Weights
Serial No.: Listed in Table

Manufacturer: Troemner
Customer ID: Listed in Table

Laboratory Environment at time of test

Temperature °C	Pressure mmHg	Humidity %RH
21.93 to 21.94	760.7 to 760.8	47.8 to 47.9

Conventional Mass Value

Nominal Value	As Found Value (g)	As Found Correction* (mg)	As Left Value (g)	As Left Correction* (mg)	Uncertainty (mg)	Tolerance (mg)
200 mg, 1000101395, #109-B	0.2000082	0.0082	0.2000082	0.0082	0.0014	0.010
100 mg, 1000126267, #109-A	0.1000065	0.0065	0.1000065	0.0065	0.0014	0.010

*Correction is the difference between the conventional mass value of a weight and its nominal value.

Comments: These weights were received in good condition and were within ASTM Class 1 tolerances As Found.

Recalibration Due: The customer has requested a 5-year calibration cycle. The calibration due date for these weights is 05/09/27. The values listed above were found at the time of calibration. Any number of factors may cause these items to drift out of calibration before the calibration interval has expired.

Accredited by the American Association for Laboratory Accreditation (A2LA) under Calibration Laboratory Code 115953 and Certificate Number 1550.01. This laboratory meets the requirements of ISO/IEC 17025:2017 *General Requirements for the Competence of Testing and Calibration Laboratories*. This laboratory also meets the requirements of ANSI/NCSL Z540-1-1994 and any additional program requirements in the field of calibration.

page 2 to 2

Quality Control Services, Inc.
Metrology Laboratory Manager
E-mail dthompson@qc-services.com

Date: 05/09/22

Signature David S. Thompson

This document shall not be reproduced, except in full, without the written approval of Quality Control Services Mass Laboratory.

Member: National Conference of Standards Laboratories and Weights & Measures

Report and Certificate of Calibration



www.Cal-Cert.com

Toll Free
800-356-4662

Address
5777 SE International Way
Milwaukie, OR 97222

Local
503-654-9620



Report #: 31538-218157-14 **Customer PO#:**
Customer Name: PFS TECO
Customer Address: 11785 SE Highway 212, Suite 305
City: Clackamas **State:** OR **Zip:** 97015
Contact: Aaron Kravitz
Service Address: 11785 SE Highway 212, Suite 305 Clackamas, OR 97015

Calibration Standards

10-00209 Weight Rice Lake SN: 43334 Cal: 02/02/2022 Due: 02/28/2024 Vendor: Oregon Dept of Ag Report #: 20220092
19-00269 Thermo-Hygrometer Comark SN: 6237360167 Cal: 08/14/2023 Due: 08/31/2024 Vendor: Cal-Cert Range: 122 °F 95 %RH Report #: 30530-30694-3646

Instrument Data

Calibration Date:	October 12, 2023	Reference:	ASTM E898-20, D4753-15
Calibration Due Date:	April 12, 2024	Cal-Cert Procedure:	CP-002
Calibration Frequency:	6 Months	Indicating System:	Digital
Manufacturer:	Sartorius	Temperature:	73 °F
Model Number:	ENTRIS224	Humidity:	52% RH
Type:	Digital Balance	Asset #:	107
Serial #:	34307497	Service Location:	Service Address
Scale Capacity:	200 grams	As Found:	PASS
		As Left:	PASS

Scale Linear Test

Instrument Range:		200.0000 grams		Resolution:		0.0001 grams		Tolerance (As Left)		Allowable Error	
Calibration Standard	As Found UUT	As Found Error	As Left UUT	As Left Error	As Left % of Error	Error	Condition	Expanded Unc. (grams)			
grams	grams	grams	grams	grams							
0.0000	0.0000	0.0000	0.0000	0.0000	0.00	0.0000	PASS	0.00000			
20.0000	19.9998	-0.0002	19.9998	-0.0002	0.00	0.0200	PASS	0.00463			
40.0000	39.9997	-0.0003	40.0000	0.0000	0.00	0.0400	PASS	0.00924			
60.0000	59.9996	-0.0004	60.0001	0.0001	0.00	0.0600	PASS	0.01386			
80.0000	79.9995	-0.0005	80.0001	0.0001	0.00	0.0800	PASS	0.01848			
100.0000	99.9994	-0.0006	99.9999	-0.0001	0.00	0.1000	PASS	0.02310			
120.0000	119.9993	-0.0007	119.9999	-0.0001	0.00	0.1200	PASS	0.02771			
140.0000	139.9991	-0.0009	140.0000	0.0000	0.00	0.1400	PASS	0.03233			
160.0000	159.9990	-0.0010	160.0001	0.0001	0.00	0.1600	PASS	0.03695			
180.0000	179.9990	-0.0010	180.0000	0.0000	0.00	0.1800	PASS	0.03926			
200.0000	199.9989	-0.0011	200.0000	0.0000	0.00	0.2000	PASS	0.04619			
100.0000	99.9994	-0.0006	99.9999	-0.0001	0.00	0.1000	PASS	0.02310			
0.0000	0.0000	0.0000	0.0000	0.0000	0.00	0.0000	PASS	0.00000			

FUNCTIONAL CHECKS					
ECCENTRIC LOAD TEST:		HYSTERESIS: Load Increments		REPEATABILITY:	
Loading position	100.0000	Test Weight Applied. % of load	Readings	Test Weight Applied	100.0000
Right	99.9999	0%	0.0000	1st	99.9999
Left	99.9998	(R1) 50%	99.9999	2nd	100.0000
Front	99.9998	100%	200.0000	3rd	99.9999
Back	99.9999	(R2) 50%	99.9999	4th	100.0000
Center	99.9999	0%	0.0000	5th	100.0000
As Left	PASS	As Left	PASS	As Left	PASS
Tolerance: The maximum error of the eccentric loading must be less than .1% of center load value.		Tolerance: The Difference of R1 and R2 must be within 0.1%		Tolerance: Deviation of lowest and highest reading within 0.1%	

Remarks:

The scale was adjusted prior to taking the As Left readings.

We sincerely thank you for your business. Please call us at 503-654-9620 for all your sales and calibration needs. Cleaning and preventative maintenance were performed as part of this service.

Cal-Cert is accredited by A2LA under Calibration Laboratory Code #4986.01.
A2LA is recognized under the ILAC mutual recognition agreement (MRA).

This certificate is hereby issued that the above instrument was tested for accuracy with calibrated standards traceable to the National Institute of Standards and Technology (NIST). The information provided on this form complies with the data gathering and reporting requirements of ISO/IEC 17025 and ANSI/NCSL Z540.1, and meets the requirements of all applicable references and Cal-Cert procedures listed above. Any stated measurement uncertainty includes the uncertainty of the Calibration standards used, combined with the uncertainty of the measurement process using the RSS method with a k=2 for an approximate 95% level of confidence. The calibration process meets or exceeds a ratio of 4:1 unless otherwise stated. All tolerances were derived from the applicable standards and pass/fail determination is based on those tolerances. The customer determined any recommended due dates indicated on the certificate.

This report shall not be reproduced except in full, without written approval from Cal-Cert.

Service Engineer:

Jon Rau

Date:

October 12, 2023

Technical Manager:

Marshall Doyle

Signature:



REPORT#: 31538-218157-14

CERTIFICATE OF ANALYSIS

Grade of Product: EPA PROTOCOL STANDARD

Part Number:	E04NI61E15A0574	Reference Number:	48-402546580-1
Cylinder Number:	CC121798	Cylinder Volume:	143.7 CF
Laboratory:	124 - Los Angeles (SAP) - CA	Cylinder Pressure:	2016 PSIG
PGVP Number:	B32022	Valve Outlet:	590
Gas Code:	CO,CO ₂ ,O ₂ ,BALN	Certification Date:	Sep 23, 2022

Expiration Date: Sep 23, 2030

Certification performed in accordance with "EPA Traceability Protocol for Assay and Certification of Gaseous Calibration Standards (May 2012)" document EPA 600/R-12/531, using the assay procedures listed. Analytical Methodology does not require correction for analytical interference. This cylinder has a total analytical uncertainty as stated below with a confidence level of 95%. There are no significant impurities which affect the use of this calibration mixture. All concentrations are on a mole/mole basis unless otherwise noted.

Do Not Use This Cylinder below 100 psig, i.e. 0.7 megapascals.

ANALYTICAL RESULTS

Component	Requested Concentration	Actual Concentration	Protocol Method	Total Relative Uncertainty	Assay Dates
CARBON MONOXIDE	4.250 %	4.306 %	G1	+/- 0.6% NIST Traceable	09/23/2022
CARBON DIOXIDE	17.00 %	17.01 %	G1	+/- 0.6% NIST Traceable	09/23/2022
OXYGEN	17.00 %	17.11 %	G1	+/- 0.7% NIST Traceable	09/23/2022
NITROGEN	Balance				

CALIBRATION STANDARDS

Type	Lot ID	Cylinder No	Concentration	Uncertainty	Expiration Date
NTRM	12061520	CC354777	19.87 % CARBON DIOXIDE/NITROGEN	+/- 0.6%	Jan 11, 2024
NTRM	98051002	SG9150866BAL	12.05 % OXYGEN/NITROGEN	+/- 0.7%	Dec 14, 2023
NTRM	08061402	CC267714	1.959 %W CARBON MONOXIDE/NITROGEN	+/- 0.6%	Jul 02, 2024

ANALYTICAL EQUIPMENT

Instrument/Make/Model	Analytical Principle	Last Multipoint Calibration
SIEMENS 6E CO2	NDIR	Sep 16, 2022
SIEMENS 6E CO HIGH	NDIR	Sep 06, 2022
SIEMENS OXYMAT 6	PARAMAGNETIC	Sep 12, 2022

Triad Data Available Upon Request



Approved for Release

**CERTIFICATE OF ANALYSIS / EPA PROTOCOL GAS****Customer & Order Information**PXPKG TUALATIN OR H
10450 SW TUALATIN SHERWOOD ROAD
TUALATIN OR 97062-9547

Certificate Issuance Date: 10/16/2019

Praxair Order Number: 71120745

Part Number: NI CD10CO33E-AS

Customer PO Number: 79106732

Fill Date: 10/08/2019

Lot Number: 70086928102

Cylinder Style & Outlet: AS CGA 590

Cylinder Pressure and Volume: 2000 psig 140 ft³**Certified Concentration**

Expiration Date:	10/16/2027	NIST Traceable
Cylinder Number:	CC139173	Expanded Uncertainty
10.09 %	Carbon dioxide	± 0.4 %
2.53 %	Carbon monoxide	± 0.6 %
10.48 %	Oxygen	± 0.4 %
Balance	Nitrogen	

ProSpec EZ Cert**Certification Information:**

Certification Date: 10/16/2019

Term: 96 Months

Expiration Date: 10/16/2027

This cylinder was certified according to the 2012 EPA Traceability Protocol, Document #EPA-600/R-12/531, using Procedure G1.
Do Not Use this Standard if Pressure is less than 100 PSIG.

CO2 responses have been corrected for Oxygen IR Broadening effect. O2 responses have been corrected for CO2 interference.

Analytical Data:

(R=Reference Standard, Z=Zero Gas, C=Gas Candidate)

1. Component: Carbon dioxide

Requested Concentration: 10 %
Certified Concentration: 10.09 %
Instrument Used: Horiba VIA-510 S/N 20C194WK
Analytical Method: NDIR
Last Multipoint Calibration: 09/18/2019

First Analysis Data:				Date	10/16/2019		
Z:	0	R:	14	C:	10.09	Conc:	10.09
R:	14	Z:	0	C:	10.1	Conc:	10.1
Z:	0	C:	10.1	R:	14.01	Conc:	10.1
UOM:	%	Mean Test Assay:			10.09	%	

Reference Standard: Type / Cylinder #: GMIS / CC164230

Concentration / Uncertainty: 14.00 % ±0.265%

Expiration Date: 04/16/2027

Traceable to: SRM # / Sample # / Cylinder #: SRM 1675b / 6-F-51 / CAL014538
SRM Concentration / Uncertainty: 13.963% / ±0.034%
SRM Expiration Date: 05/16/2022

Second Analysis Data:				Date			
Z:	0	R:	0	C:	0	Conc:	0
R:	0	Z:	0	C:	0	Conc:	0
Z:	0	C:	0	R:	0	Conc:	0
UOM:	%	Mean Test Assay:				%	

2. Component: Carbon monoxide

Requested Concentration: 2.5 %
Certified Concentration: 2.53 %
Instrument Used: Horiba VIA-510 S/N UB9UCSYX
Analytical Method: NDIR
Last Multipoint Calibration: 09/19/2019

First Analysis Data:				Date	10/16/2019		
Z:	0	R:	5	C:	2.53	Conc:	2.53
R:	5	Z:	0	C:	2.53	Conc:	2.53
Z:	0	C:	2.54	R:	5.01	Conc:	2.54
UOM:	%	Mean Test Assay:			2.53	%	

Reference Standard: Type / Cylinder #: GMIS / CC242633

Concentration / Uncertainty: 5.00 % ±0.543%

Expiration Date: 04/03/2025

Traceable to: SRM # / Sample # / Cylinder #: SRM 2642a / 51-D-23 / FF23106
SRM Concentration / Uncertainty: 7.859% / ±0.039%
SRM Expiration Date: 07/15/2019

Second Analysis Data:				Date			
Z:	0	R:	0	C:	0	Conc:	0
R:	0	Z:	0	C:	0	Conc:	0
Z:	0	C:	0	R:	0	Conc:	0
UOM:	%	Mean Test Assay:				%	

3. Component: Oxygen

Requested Concentration: 10.5 %
Certified Concentration: 10.48 %
Instrument Used: OXYMAT 5E
Analytical Method: Paramagnetic
Last Multipoint Calibration: 09/18/2019

First Analysis Data:				Date	10/16/2019		
Z:	0	R:	9.88	C:	10.49	Conc:	10.48
R:	9.88	Z:	0	C:	10.49	Conc:	10.48
Z:	0	C:	10.5	R:	9.89	Conc:	10.49
UOM:	%	Mean Test Assay:			10.48	%	

Reference Standard: Type / Cylinder #: NTRM / DT0010384

Concentration / Uncertainty: 9.875 % ±0.4%

Expiration Date: 11/18/2022

Traceable to: SRM # / Sample # / Cylinder #: NTRM / 170701 / NTRM DT0010384
SRM Concentration / Uncertainty: 9.875% / ±0.040%
SRM Expiration Date: 11/18/2022

Second Analysis Data:				Date			
Z:	0	R:	0	C:	0	Conc:	0
R:	0	Z:	0	C:	0	Conc:	0
Z:	0	C:	0	R:	0	Conc:	0
UOM:	%	Mean Test Assay:				%	

Analyzed By

Jose Vasquez

Certified By

Jenna Lockman (Signature)

Report and Certificate of Calibration



www.Cal-Cert.com



Toll Free
888-700-4100

Address
120 S. Chaparral Ct Suite 110
Anaheim Hills, CA 92808

Local
714-696-5300

Report #: 31678-218361-1546 **Customer PO#:** 1102
Customer Name: PFS TECO
Customer Address: 11785 SE Highway 212, Suite 305
City: Clackamas **State:** OR **Zip:** 97015
Contact: Ethan Frederick
Service Address: 120 S. Chaparral Court, Suite 110 Anaheim Hills, CA 92808

Calibration Standards

ACS374 Thermo-Hygrometer Vaisala SN: D0140002 Cal: 03/09/2023 Due: 03/31/2024 Vendor: Vaisala Range: 356 °F Report #: 230309-HMP77B-D0140002

Instrument Data

Calibration Date:	October 27, 2023	Reference:	ASTM E-104
Recommended Due Date:	October 27, 2024	Cal-Cert Procedure:	CP-012 / CP-031
Calibration Frequency:	12 Months	Indicating System:	Digital
Manufacturer:	Traceable	Temperature:	70 °F
Type:	Temperature & Humidity	Humidity:	50% RH
Model Number:	653718004-13	Asset #:	201
Serial #:	210735280	Service Location:	Cal-Cert Lab
Temperature Capacity:	158 °F	As Found:	PASS
Temperature Resolution:	0.1 °F	As Left:	PASS
RH Capacity:	95 %RH		
RH Resolution:	0.1 %RH		

TEMPERATURE READINGS

Tolerance: ± 0.7 °F

CALIBRATION STANDARD °F	UUT AS FOUND °F	UUT VERIFICATION READING #1 °F	UUT VERIFICATION READING #2 °F
70.31	70.9	70.9	70.9
Expanded Uncertainty ±		0.18 °F	

HUMIDITY READINGS

Tolerance: ± 3 %RH

CALIBRATION STANDARD %RH	UUT AS FOUND %RH	UUT VERIFICATION READING #1 %RH	UUT VERIFICATION READING #2 %RH
50.51	51.7	51.7	51.7
Expanded Uncertainty ±		1.9 %RH	

Manufacturer: Traceable

Type: Temperature & Humidity

Serial #: 210735280

Remarks:

**We sincerely thank you for your business. Please call us at 714-696-5300 for all your sales and calibration needs.
Cleaning and preventative maintenance were performed as part of this service.**

Cal-Cert is accredited by A2LA under Calibration Laboratory Code #4986.02.
A2LA is recognized under the ILAC mutual recognition agreement (MRA).

This certificate is hereby issued that the above instrument was tested for accuracy with calibrated standards traceable to the National Institute of Standards and Technology (NIST). The information provided on this form complies with the data gathering and reporting requirements of ISO/IEC 17025 and ANSI/NCSL Z540.1, and meets the requirements of all applicable references and Cal-Cert procedures listed above. Any stated measurement uncertainty includes the uncertainty of the Calibration standards used, combined with the uncertainty of the measurement process using the RSS method with a k=2 for an approximate 95% level of confidence. The calibration process meets or exceeds a ratio of 4:1 unless otherwise stated.

All tolerances were derived from the applicable standards and pass/fail determination is based on those tolerances. The customer determined any recommended due dates indicated on the certificate.

This report shall not be reproduced except in full, without written approval from Cal-Cert.

Service Engineer: John Story

Date: October 27, 2023

Technical Manager: Marshall Doyle

Signature: 



CERTIFICATE OF CALIBRATION

CUSTOMER:	PFS-TECO; CLACKAMAS, OR	CALIBRATION DATE:	05/23/2023
PO NUMBER:	1096	CALIBRATION DUE:	05/23/2024
INST. MANUFACTURER:	AQUATECH SCIENTIFIC INSTRUMENTS	PROCEDURE:	NAVAIR-17-20MP-03
INST. DESCRIPTION:	DIGITAL BAROMETER	CALIBRATION FLUID:	AIR @ 70F
MODEL NUMBER:	DBX2	STANDARD(S) USED:	A321, A22 DUE 3-2024
SERIAL NUMBER:	118222	NIST TRACE # 'S':	1236086968,1583142077
RATED ACCURACY:	+/- .18 mmHGA	AMBIENT CONDITIONS:	757 mmHGA, 60% RH, 68F
UNCERTAINTY GIVEN:	+/- .03mmHGA.;k=2	CERTIFICATE FILE #:	533813
NOTES:	AS REC./AS LEFT WITHIN SPECS. ** DECISION RULE: PFA NOT USED TO DETERMINE CONFORMITY **		

TEST POINT NUMBER	UUT INDICATED mmHGA	DM.STD. ACTUAL mmHGA	% RD. ERROR
1	605.24	605.330	0.015
2	635.45	635.525	0.012
3	678.24	678.303	0.009
4	702.18	702.258	0.011
5	724.19	724.295	0.014
6	757.11	757.231	0.016
7	775.39	775.525	0.017

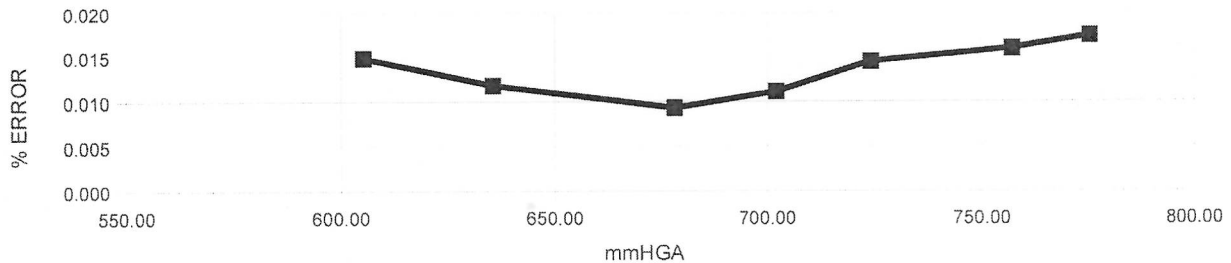

All instruments used in the performance of the shown calibration have traceability to the National Institute of Standards and Technology (NIST). The uncertainty ratio between the calibration standards (DM.STD.) and the Unit Under Test (UUT) is a minimum of 4:1, unless otherwise noted. Calibration has been performed according to the shown procedure. The use of IAS/ILAC logo indicates calibrations are in accordance to ISO/IEC 17025:2017.

Dick Munns Company · 11133 Winners Circle, Los Alamitos, CA 90720
Phone: 714-827-1215 · www.dickmunns.com

This Calibration Certificate shall not be reproduced except, in full, without approval by Dick Munns Company. The data shown applies only to the instrument being calibrated and under the stated conditions of calibration.

Issuing Date:

5-23-2023

Approved By:

Cal. Technician:

Calibrated at: Lab

On-Site (Customer's)

Page 1 of 1